

Northwest Territories

**Professional
Driver's Handbook**



**Northwest
Territories** Transportation

PREFACE

A professional driver must constantly demonstrate a courteous attitude and exercise sound judgement. To qualify for his particular licence to drive, he must acquire knowledge, develop skills, possess the necessary physical and mental qualifications.

Your future as a professional driver might very well be decided by how well you study and absorb the information contained in this manual, and how conscientiously you practice the principles contained herein.

Experienced professional drivers will find this guide helpful in assisting them to improve their driving. Moreover, it will enable them to understand better the increasingly complex nature of their calling and the constantly changing control measures demanded by an ever changing traffic environment.

You can make driving a safe and enjoyable experience for yourself and others who share the road with you. The responsibility, therefore, is essentially yours.

Motor Vehicle Branch

Credit for the compiling of this manual goes to the Saskatchewan Highway Traffic Board.

TABLE OF CONTENTS

Preface	1	Height	18
Table of Contents	2	Overheight	19
N.W.T. Driver's Class Licence Program	3	Length	19
Health Standards	4	Overlength	19
Good Driving Habits	5	Width	20
Attitude Towards Driving	5	Overwidth	20
Emotional Attitude	5	Overweight	20
Following Distance	5	Weigh Scale and Enforcement	20
Space Between Vehicles in a Motorcade	6	Permits	20
The General Rule for Following	6	Pilot Car Requirements	21
The Tailgater	6	About Loads and Loading	21
Intersections	7	Weight Distribution	21
Danger Zones	8	Approximate Distribution of Total Weight	23
Shrinking the Danger Zones	9	Securing Loads	24
Speed, Weight, Stopping	9	Special Cargos	24
Alleys, Lanes and Side Roads	9	Coupling a Tractor and Trailer	25
Overtaking and Passing	9	Uncoupling a Tractor and Trailer	25
Passing on the Right	10	"Train" or "Pup Train"	26
Observe Centre-Line Markings	10	Hooking up a "Train" or "Pup Train"	26
Curves and Jack-Knifing	11	Connecting Vehicles	27
Cruising Speed	13	Pre-Trip Vehicle Inspection	27
Lugging	13	The School Bus	28
Engine Operation	13	Pre-Trip Inspection, All Single Unit Vehicles	29
Overspeeding	13	Pre-Trip Inspection, Air Brake Vehicles	30
Coasting	13	Pre-Trip Inspection, Vehicles Equipped with Vacuum Assisted Brakes	30
Downhill	13	Pre-Trip Inspection, Buses Other Than School Buses	31
Braking	14	Pre-Trip Inspection, Trailer- Semi Trailer	32
Combination Braking	15	Mirrors	32
Water on Roadways	15	Tires and Pressure	32
Traffic Tempo	15	Bleeding Pressure	33
Parking a Vehicle on Highways	16		
Backing	16		
Loads and Unloading	18		
Vehicle Dimensions	18		

Tire Pressure and Tire Wear	33
Professional Drivers Practices	33
Putting a Vehicle into Motion (Gasoline Powered, Not Governed)	33
Putting a Vehicle into Motion (Gasoline or Diesel With Engine R.P.M. Governed)	33
Using an Engine Tachometer in Shifting	33
Shifting up Through the Gears (Main Transmission)	35
Shifting Down	35
Steering Manoeuvres	35
Steering Forward	35
Steering Backward	38
Steering U-Turn	38
Passenger Carrying Vehicles	39
Right Turns	39
Left Turns	40
Leaving the Curb	40
Parked Cars	40
Safety Provisions	40
Driver's Vision	41
Standing Passengers	41
Fire Fighting	41
About Fire Extinguishers	42
Emergency Vehicles	42
Duties of Other Drivers	43
Repair Vehicles	43
Taxicabs	43
Suggested Practice for Taxicab Drivers	44
Things You Should Know	45

NORTHWEST TERRITORIES DRIVER'S
CLASS LICENCE PROGRAM

"Class 1" Permits the operator of truck-tractor-trailer combinations exceeding 11,000 kg (24,000 lbs) G.V.W. where the trailer exceeds 4,600 kg (10,000 lbs) G.V.W.; vehicles included in Classes 2, 3, 4 or 5; and, as a learner, vehicles included in Class 6.

"Class 2" Permits the operation of buses having a seating capacity exceeding 24 passengers; vehicles included in Classes 3, 4 or 5; and, as a learner, vehicles included in Class 1 or 6.

"Class 3" Permits the operation of single trucks exceeding 11,000 kg (24,000 lbs) G.V.W.; truck-trailer combinations not exceeding 11,000 kg (24,000 lbs) G.V.W. where the trailer exceeds 4,600 kg (10,000 lbs); truck-trailer combinations exceeding 11,000 kg (24,000 lbs) G.V.W. where the trailer does not exceed 4,600 kg (10,000 lbs) G.V.W.; vehicles included in Classes 4 or 5 and, as a learner, vehicles included in Class 1, 2 or 6.

"Class 4" Permits the operation of buses having a seating capacity not exceeding 24 passengers, taxi and ambulances; vehicles included in Class 5; and as a learner, vehicles included in Class 1, 2, 3 or 6.

School bus drivers must also comply with any further requirements established by Commissioner's regulation.

"Class 5" Permits the operation of single motor vehicles not exceeding 11,000 kg (24,000 lbs) G.V.W.; motor vehicle-trailer combinations not exceeding 11,000 kg (24,000 lbs) G.V.W. where the trailer does not exceed 4,600 kg (10,000 lbs) G.V.W.; and, as a learner, vehicles included in Class 1, 2, 3, 4 or 6.

"Class 6" Permits the operation of motorcycles and, as a learner, vehicles included in Class 5.

"Class 7" Permits the operation as a learner of vehicles included in Class 5 or 6.

CLASS 1 - 4 HEALTH STANDARDS

MEDICAL

- Must file a completed medical certificate on initial application, or when requested; thereafter, a medical certificate must be filed every five years to age 44, every two years from age 45 to 64, and annually from age 65 on. For school bus, annual medical required.

VISION

- Must have vision in both eyes.
- Acuity not less than 20/50 in poorer eye, 20/30 better eye and 20/30 with both eyes (Snellen Rating) with or without correction.
- No diplopia (double vision).
- Field of vision not less than 140 degrees in each eye.

HEARING

- Must be good in both ears.
- The use of hearing aids is not acceptable (in instances of hearing impairment, an audiogram report may be required).

PHYSICAL CONDITION

- Applicants will be required to submit a report of a medical examination on a prescribed form, and meet the standards prescribed in the Guide for Physicians in Determining Fitness to Drive a Motor Vehicle by the Canadian Medical Association. Some of the conditions which would prohibit the issuance of a Class 1, 2, 3, or 4 licence are:

Epilepsy	Certain heart conditions
Certain diseases of the brain	Multiple sclerosis
Parkinson's disease	Certain diabetic conditions

- Amputees and persons suffering from disabilities which interfere with functions such as a loss of rotation of the head, paralysis of any limb, disabling rheumatism or arthritis may not be allowed to drive Class 1, 2, 3, or 4 vehicles.

EXAMINATIONS

The examination of drivers for a Class 1, 2, 3 or 4 drivers licence includes:

- Vision screening test based on the vision standards established for the classification sought.
- A medical report of the driver's physical condition.
- A knowledge examination, based on the information contained in this manual and driver manual.
- A complete pre-trip inspection of the vehicle by the applicant.
- A road test in a vehicle of the type described in the class of licence sought.

The vehicle must be supplied by the applicant.

GOOD DRIVING HABITS

ATTITUDE TOWARDS DRIVING

An improper attitude of mind in a driver is perhaps the chief contributing factor in motor vehicle accidents.

To qualify as a safe motor vehicle driver, you must not only respect the law, but also you must understand the need for traffic regulations. All drivers must observe the laws and regulations covered in The Vehicles Ordinance with the realization that there may be other drivers who do not know or always obey these laws.

As a professional driver, you must practice defensive driving techniques by being willing, at all times, to yield to other vehicle operators and pedestrians.

EMOTIONAL ATTITUDE

There are certain conditions that could upset your emotional attitude such as worry, anger or anxiety which may prey on your mind and distract your attention from the driving task.

Safe driving demands your complete attention at all times. You can't control your vehicle if you're not in control of yourself.

Drowsiness and fatigue are two of the most dangerous hazards to guard against because they may overtake and overcome any driver anytime, in spite of all efforts made to remain alert.

Sufficient rest and sleep are most important in maintaining proper health standards. Individual requirements vary, but usually seven or eight consecutive hours of sleep are necessary to good health.

During a long road trip, you should not drive for excessively long periods without a break. This will help relieve the monotonous condition that develops which reduces your alertness and attention - both essential for safe driving.

FOLLOWING DISTANCE

All drivers should be constantly on the defensive to prevent a "rear-end" collision with other vehicles. This applies not only to the vehicle they are following, but also to the vehicles following them.

The collision from behind may not always be avoidable, but you can do much to reduce that probability. The first step in prevention is assuring that your own "stops" are smooth and gradual. To do this, practise these simple but effective driving habits:

1. Look well ahead at the traffic to pick out the clues which indicate speed changes and stops developing in the traffic pattern.
2. Look ahead for traffic control devices and lights to anticipate light changes before reaching the intersection. Traffic lights which have been green for some time before you reach the intersection could change at any

time. Some streets have synchronized lights, permitting drivers to travel long distances without stopping.

3. Maintain an adequate following distance from the vehicles ahead so that a smooth, gradual stop may be completed, even though the vehicle ahead has made a "panic stop".

SPACE BETWEEN VEHICLE IN A MOTORCADE

Drivers of semi-trailer trucks and buses sometimes drive in a caravan, the first truck in line breaking wind resistance for the trucks following close behind, thereby leaving insufficient stopping distance and preventing faster traffic from passing one truck at a time.

THE GENERAL RULE FOR FOLLOWING

The general rule has been to allow at least one car's length for every 16 km/h of speed that you are driving, but the best rule of all is to maintain a two second interval between your vehicle and the vehicle ahead. Just what does this mean? It's really quite simple if you follow these two steps:

1. As the vehicle in front of you passes any stationary point of reference, for example, a patch of oil on the pavement, a power pole, a road sign, a bridge or overpass, count seconds - out loud at first - by simply saying "one thousand and one, one thousand and two".
2. If the vehicle you are driving reaches the reference point you selected before "one thousand and two", you are following too closely. You should drop further back. If, however, you have finished your count before you reach your point of reference, then your following distance is actually greater than required, giving you an extra safety cushion.

This is a simple procedure. Furthermore, it works under all circumstances for all types and classes of vehicles. It requires little practice, but is a most worthwhile undertaking.

THE TAILGATER

A driver of commercial vehicles, such as buses, trucks and tractor trailers, must rely on outside mirrors for rear vision. A tailgater often sits in the blind spot directly behind the commercial vehicle, and may not be observed.

It may not always be possible for you to prevent a rear-end collision by such an irresponsible driver. There is a bonus factor, however. If your stop is gradual, his speed of impact will be considerably less than if you stopped suddenly.

The tailgater is usually a person who lacks patience as well as foresight. This lack of patience could be caused by your vehicle's speed and its handling by you. By observance of the rear mirrors, you can often protect a tailgater by assisting him in passing your vehicle. He is easier to deal with if he is ahead of you, than if he is behind you. Don't let him put his accident on your record!

Upon approaching an upgrade where there is a passing lane provided, the driver of a vehicle which is travelling slower than the normal traffic speed must use the right lane. Where such lanes are not provided, the driver of a slower vehicle should allow the traffic which has built up behind his vehicle to overtake at the earliest safe opportunity.

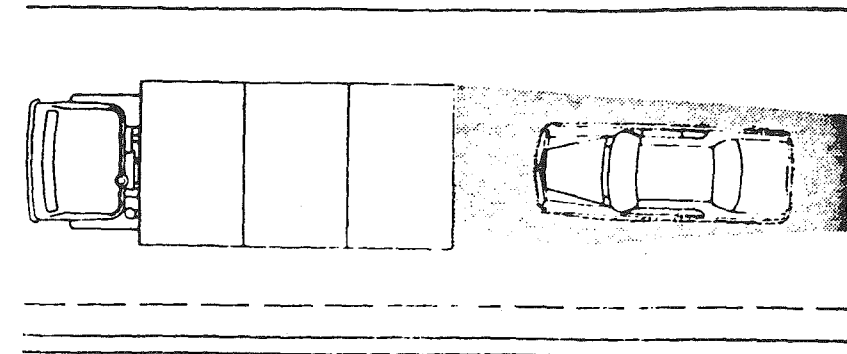

INTERSECTIONS

The basic right-of-way rules are explained in the N.W.T. Driver's Handbook.

Most hazards occur at intersections and knowledge of the right-of-way rules is essential for all drivers. As a defensive driver, you should not depend on other drivers always to obey these rules. To avoid intersection accidents, it is suggested that you follow these common sense practices;

1. Never enter a limited view intersection at a speed at which you cannot stop safely, should you need to do so.
2. Do not assume you have the right-of-way, even when it is reinforced by traffic lights or traffic signs. Look left and right before entering any intersection. Look for and expect the violator to run the sign or lights.
3. Be alert and anticipate a change of a green light to avoid running through an amber or red light. When getting the green "Go" light, check right, left and ahead for the "Late Runners", before proceeding.
4. Do not depend on other drivers to signal or execute their turns correctly.
5. It is not a good practice to pass at the approach to, or in an intersection. In fact, it's unlawful to pass at an intersection outside of built-up areas (i.e. an open highway).

The professional driver does not use the size of his vehicle to "bluff" for the right-of-way. He gives the right-of-way rather than taking it. He gives all his attention to each and every intersection, laneway, or driveway with his vehicle in full control.

DANGER ZONES

The danger zone of any vehicle can be described as the area directly in front of the vehicle in which the vehicle cannot STOP. In the diagram below, the danger zone is shown as the shaded area. As the speed increases the danger zone increases; if the road condition is less than ideal, such as rain, snow, ice or gravel, etc., the danger zone is further increased. When you fail to reduce your vehicle's speed to suit these road conditions, the danger zone increases further.

2

At 32 km/h you can stop - JUST!

The truck is approximately three and one-half car lengths from the cross-walk when the driver sees the pedestrian. Under ideal conditions, he may be able to stop just in time!

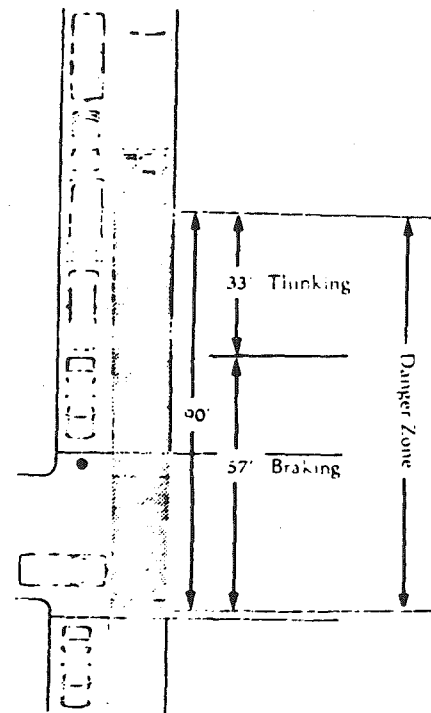
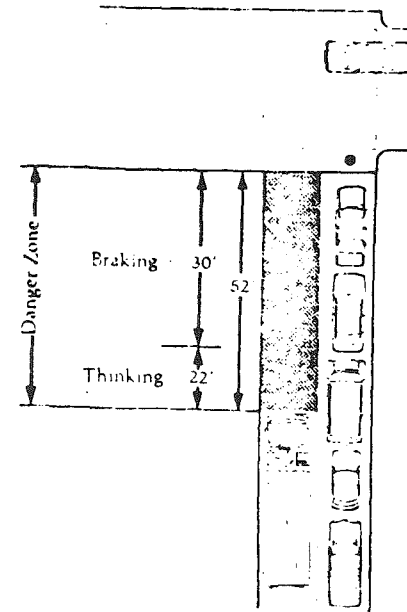

3

At 48 km/h you cannot stop in time!

Even under ideal conditions, the driver of the truck cannot stop in time! Both the pedestrian and the car on the right are about to enter the danger zone!

The distances in the diagrams are approximations only for illustration, as braking distances will vary according to the weight of the vehicle, condition of the brakes, and the condition of the road surface.

Commercial vehicles, like passenger vehicles, can have their stopping distances decreased when conditions become less than ideal, by one sure means: **REDUCE THE SPEED.**

If another vehicle, or a pedestrian should enter the danger zone, the driver cannot stop his vehicle in time; it is not physically possible.

SHRINKING THE DANGER ZONES

The illustration of the danger zones shows how the distance is shortened if the speed of the vehicle is reduced.

The zone can also be reduced if you form the habit of "covering the brake", at any time you recognize potential danger developing. In diagram 4, the driver has recognized that he is nearing an intersection which is a danger spot. He knows the line of cars on his right may hide hazards from his view. He removes his foot from the accelerator, and places it lightly on the brake. When he first sees the hazard, his reaction time has been reduced because he has removed his foot from the accelerator. Therefore, his stopping distance has been reduced and he now has a better chance of stopping before the cross-walk, rather than across the intersection.

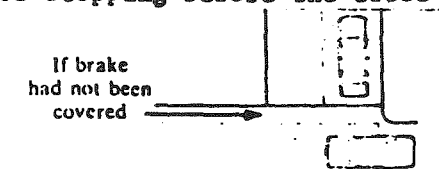

4

Speed, Weight, Stopping

If the weight of the vehicle is doubled, it requires double the braking force to stop the vehicle. If the speed is doubled, it requires four times the braking force to stop the vehicle.

If the weight and the speed is doubled, it requires eight times the braking force to stop the vehicle.

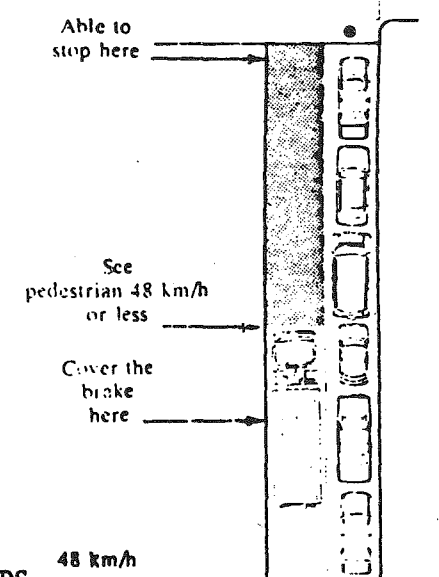

ALLEYS, LANES AND SIDE-ROADS

The driver of a vehicle shall, before entering a street from a lane or alley within a city or town, bring the vehicle to a dead stop and shall not proceed until it is safe to do so.

OVERTAKING AND PASSING

Overtaking and passing another vehicle should only be attempted when you are sure you have the time and space to do so safely.

If it is absolutely necessary to overtake and pass another vehicle, you should take the following precautions:

1. Check ahead to ensure there is adequate clear distance to pass safely.
2. Check to the rear to see that no other vehicle may be attempting to overtake and pass your vehicle.
3. Signal your intention to pass. Move into the passing lane by using your turn signal indicator.
4. Gain adequate passing speed before moving into the passing lane.
5. If there is danger that the driver ahead may cut into your passing lane, you may want to use your horn, or at night, flash the high and low head-light beams a few times.
6. When you have passed the vehicle, you should use your turn signal indicator to signal your intention to move right to the driving lane.
7. Move into the right lane only when you are sure you are well ahead of the vehicle passed and you can move back safely.

A courteous professional driver who is about to be overtaken and passed should move as far to the right as is reasonable and make it easy for the other vehicle to pass safely.

PASSING ON THE RIGHT

Passing on the right is permitted only:

1. When overtaking another vehicle making a left turn or signalling intent to make a left turn.
2. On one-way traffic streets; or
3. On streets and highways marked for multi-lanes.

YOU MUST NOT DRIVE OFF THE ROADWAY ONTO THE SHOULDER TO PASS ANOTHER VEHICLE.

OBSERVE CENTRE-LINE MARKINGS

Centre-line markings are intended for your protection. A solid line at the left of your lane means it is unsafe to pass. A broken line means you may pass if the way ahead and to the rear is clear.

The centre-line of a highway is often referred to as a "life line". Never put your "life on the line". Keep as far to the right of the centre line as is reasonable.

PASSING

On occasion, drivers of commercial vehicles are guilty of breaches of driving etiquette which can irritate the motoring public. Such a breach is the passing

of one commercial vehicle by another when the speed differential is so slight that a considerable time is involved in executing the pass. In doing this, the passing truck occupies the fast traffic lane when it is not absolutely necessary, thus causing the following traffic to reduce its speed, resulting in bunching. "Bunching" on freeways and fast highways is a hazard leading to trouble.

BEING PASSED

DO NOT DIRECT the vehicle following you to pass, let him make his driving decision. You may be encouraging a driver with limited experience to overdrive his ability.

Do not encourage following traffic to overtake your vehicle when it would necessitate his crossing over no-passing lines.

When he does make his move, help him complete his pass by not increasing your speed. If there is any danger where the passing driver does not have sufficient space, reduce your speed if necessary.

Large commercial vehicles have a louder exhaust resonance than the passenger vehicles. Their size and highway noise often gives the impression of travelling at higher speeds than they actually are.

Large commercial vehicles travelling at high speeds create varying degrees of air turbulences that can be hazardous to smaller passenger vehicles. A car riding directly in front of the truck, alongside the saddle tank area, or, at the immediate rear of the trailer, is in an area of air turbulence. Be alert for the inexperienced driver who rides in these areas, he may be forced off a narrow roadway or drawn into the side of the vehicle.

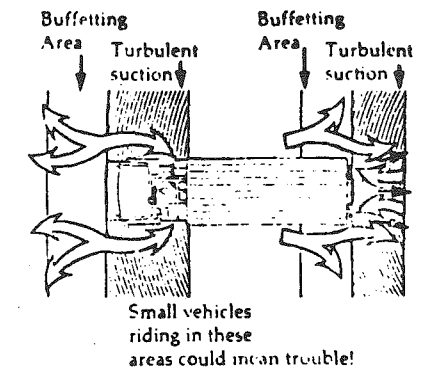

5

CURVES AND JACK-KNIFING

A vehicle travelling in a straight line develops a force called momentum. The higher the speed, the greater the force. When the vehicle enters a curve, it must overcome the force of momentum if it is to change its direction from the straight line in which it has been travelling. The action of a vehicle travelling around a curve develops a force called centrifugal force. The greater the speed at which an object travels around a curve the greater the centrifugal force developed. This centrifugal force tends to push outwards from the centre of the curve and tries to keep the object on its original straight line.

The degree of control a driver is able to maintain over his vehicle is determined by the amount of traction the vehicle's tires have with the road surface. Entering a curve to fast can result in skidding or a roll-over; applying brakes in a curve can cause a skid or a jack-knife.

To avoid rolling, skidding or jack-knifing, reduce speed before the curve. Enter the curve at a speed that will not require braking. This will permit the driver to apply gradual power in the curve. The application of a small amount of power in a curve counteracts the centrifugal force.

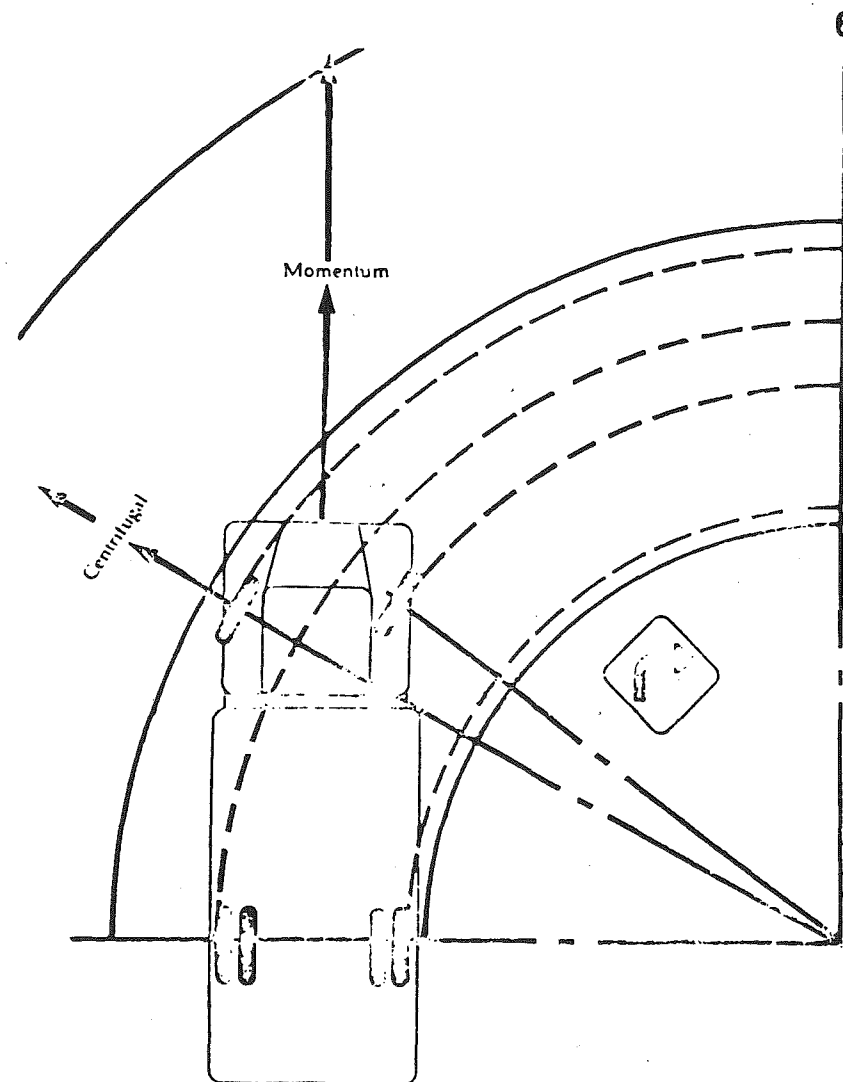

For the safe negotiation of curves, here are some tips to follow:

1. Spot the curve soon enough - heeding the curve sign warning and suggested speed - adjusting your speed to existing conditions.
2. Slow down before entering the curve.
3. Apply power to the wheels when in the curve as conditions permit.

CRUISING SPEED

Cruising speed is attained by proper selection of a gear in relation to the engine RPM. It is generally accepted that a vehicle is in the correct gear if it can be accelerated without causing the engine to lug.

LUGGING

This simply means the driver has not selected the proper gear that will allow the engine to pull the vehicle without labouring and at low RPM.

It has been found that drivers trained on the matter of engine RPM and gear shifting have extended the life of their motors by many thousands of miles as well as decreasing fuel consumption.

ENGINE OPERATION

The operation of an engine to combine efficiency, economy and trouble-free mileage is dependent on you, the driver, and the care you take in selecting the gear which allows the engine to operate at a speed within its efficiency range. Most manufacturers recommend an engine speed of 85% of engine governed speed.

Most engines are fitted with governors by the manufacturer to control engine speed to its efficient maximum. By knowing the governed speed of an engine and observing the engine tachometer, a driver should be able to select gears that will keep the vehicle operating at its most efficient peak.

OVERSPEEDING

The engine is protected from excessive RPM by the governor when being accelerated, but no such control exists when the vehicle is running downhill. Care must be taken so that the engine never exceeds the governed RPM when descending a hill.

COASTING

Descending hills with the transmission in neutral, or in gear with the clutch pedal depressed, is a very dangerous practice and should never be attempted. As the momentum increases in this situation, it is difficult to place the transmission in gear, and to engage the clutch would cause extensive damage to the transmission and drive train.

DOWNHILL

All downgrades should be traversed within the governed range of the vehicle under normal operating conditions. However, if the hill is steep, you would be well advised to reduce the gear ratio to a lower gear as a means of assisting the braking of the vehicle. Should the momentum result in the engine coming close to the maximum RPM, then the brakes should be applied with sufficient severity to control the vehicle speed to coincide with the manufacturer's RPM. If this is done, you will realize the vehicle has not free momentum but is under control. When approaching the bottom of the hill and noting that a hill must be climbed immediately, you must release the brakes, change the gear, to a higher gear and pick up speed. As the new hill is approached, the tachometer should be watched, and you should make the desired gear shifting changes so that this new hill can be traversed in a gear ratio that allows the motor always to pick up, never lugging.

The mainshaft failure can be attributed to coasting a loaded vehicle with the clutch disengaged and with the transmission in gear. Let us assume you are coasting a loaded vehicle with the clutch pedal depressed and that you re-engage the clutch to slow the vehicle by the use of engine compression. The sudden deceleration caused by inertia and compression in the engine will shock the load and damage various units of the drive-line.

BRAKING

Bringing a vehicle to a stop on a level roadway usually requires only a single application of the braking system. The degree of application is determined by the speed, weight and degree of emergency.

For a gradual stop, you ease off the amount of brake application once the speed of the vehicle has been decreased sufficiently. You can perfect your stops by practising the amount of brake application release to prevent a jerk-back at the stop. This braking skill, coupled with the factors of:

- looking ahead to time your stops;
- maintaining safe following distances;
- setting your speed in relation to your seeing distance ensures a smooth stop every time.

To proceed down a slight grade, you can control the speed of your vehicle by "snubbing" the brakes. That is, you make brake applications at intervals, checking the vehicle's speed and then releasing them. This avoids overheating the brakes, preventing brake fade. Stopping on an icy road surface requires that you lightly snub the brakes to keep the wheels from locking.

A slowly revolving wheel on an icy surface will give you more effective traction and steering control than locked wheels.

To descend a steep grade requires a different technique. If you allow the speed to increase and then attempt to check the speed by the "snubbing" action, the brakes could generate excessive heat resulting in brake fade. On a long, steep downgrade an air brake equipped vehicle could have the main air pressure reservoir seriously decreased by repeated applications of the brakes. Therefore, to proceed down the steep grade, select the lower gear ratio appropriate to your vehicle's weight, condition of the road surface and speed, and give steady brake application to hold your vehicle to a lower speed. This will result in less heat build-up in the brakes than intermittent applications at higher speeds.

To determine the safe speed to travel down a steep grade, you must remember one factor: you must drive at a speed which will allow you to have control of your vehicle under all conditions.

Should you be unable to stop and prevent an accident, the fact that you were travelling downhill is no excuse; your speed should have been adjusted to that condition.

The driver who attempts to justify speeding or going too fast because he was going downhill is neither a professional nor a defensive driver. The professional driver uses brakes and gear selection to control his vehicle and doesn't need excuses.

COMBINATION BRAKING

In a combination of vehicles (such as a truck-tractor and trailer, or tractor with a semi-trailer unit) equipped with an air brake system, the trailer brakes are applied along with the tractor brakes by the use of the foot control valve. This is often referred to as "Balanced Braking". The application pressure of the trailer brakes is equal to the application pressure of the tractor brakes. The trailer brakes may be applied independently of the tractor brakes by the use of the hand control valve. If you wish, you may increase the amount of application on the trailer brakes during a foot valve application by using a higher application with the hand valve. Trailers equipped with electric or vacuum brakes are operated in a similar manner. Caution must be exercised in making brake application when the vehicle is negotiating a curve or travelling on wet or icy surfaces. Overbraking could result in "jack-knifing" or "skidding".

WATER ON ROADWAYS

Water entering brake drums will reduce the braking efficiency. Avoid running through large amounts of water whenever possible. Place a slight drag on the brakes when it becomes necessary to run through water, to reduce the amount of water admitted to the drums and shoes. During excessively wet conditions, or after passing through water, test the brakes for operation. It may be necessary to drag the brakes slightly for a short distance to dry them out and restore normal braking. Always reduce your speed before driving through large pools of water on the roadway.

You must assess such conditions as:

Road - frost, ice, rain, etc.

Tire - tread, inflation

Light - glare, shadows

Visibility - dusk, rain, fog, smoke, dust

Traffic density - vehicles, pedestrians, cyclists

Load - weight, length, width, type

Driver - fatigue, tension.

TRAFFIC TEMPO

You must set your speed according to the existing conditions, but at the same time, fit your vehicle's speed to match the traffic tempo. If you drive faster than the traffic flow, you are increasing your chances of an accident ahead. By doing so, you reduce your safe following distances, and thus lose your stopping space in front. In addition, you tend to make more lane changes to thread your way past the vehicle ahead; increasing your chances for collision. Your driving decisions are also increased because you are creating more driving problems and are also increasing the odds that you will make a wrong decision. Faster driving results in faster mental fatigue. Reading the traffic pattern ahead requires that you scan the full picture ahead and to the sides by moving your eyes. The faster you push through traffic, the more rapid the scanning process, which builds tension and fatigue.

If you travel appreciably slower than the tempo of the traffic, you increase your accident potential from behind and from the sides. Vehicles following too closely behind, vehicles passing, create hazards. Vehicles over-taking and cutting in are continually occupying your stopping space.

PARKING A VEHICLE ON HIGHWAYS

1. Never park your vehicle in a manner that would block other drivers' view of an intersection. Preferably park 500 feet or more away from an intersection, when stopping for a break.
2. Set the parking brake in the power unit to ensure that your unit will stay in position when parked.
3. If the engine is shut off, place the transmission in the lowest forward or reverse gear.
4. If the vehicle is on a grade, turn the front wheels in the appropriate direction.
5. UNDER NO CIRCUMSTANCES SHOULD YOU USE THE TRAILER HAND VALVE TO HOLD A PARKED UNIT WHICH IS TO BE LEFT UNATTENDED.

BACKING

Backing becomes dangerous at any time you neglect to ensure the way is clear during the entire manoeuvre.

Investigations of "backing accidents" often indicate that they are not "accidents" but are evidence of the failure to observe.

All drivers can reduce backing accidents if they follow these backing rules.

Guide has view of Vehicle's path and eye contact with driver

7

Guide has view of Vehicle's path and eye contact with driver.

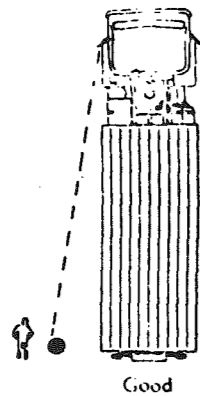

Good

Guide has no view of Vehicle's path.

Guide has no view of Vehicle's path.

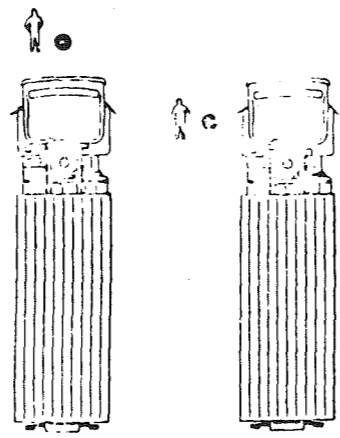

Poor

Poor

1. Avoid unnecessary backing - plan ahead to minimize backing distances.
2. Use a guide whenever possible. The guide should place himself where he has a clear continuous view of the backing path the vehicle will follow and still is visible to you throughout the manoeuvre.
3. Whenever possible, plan your approach so that you can view the area into which you will be backing.

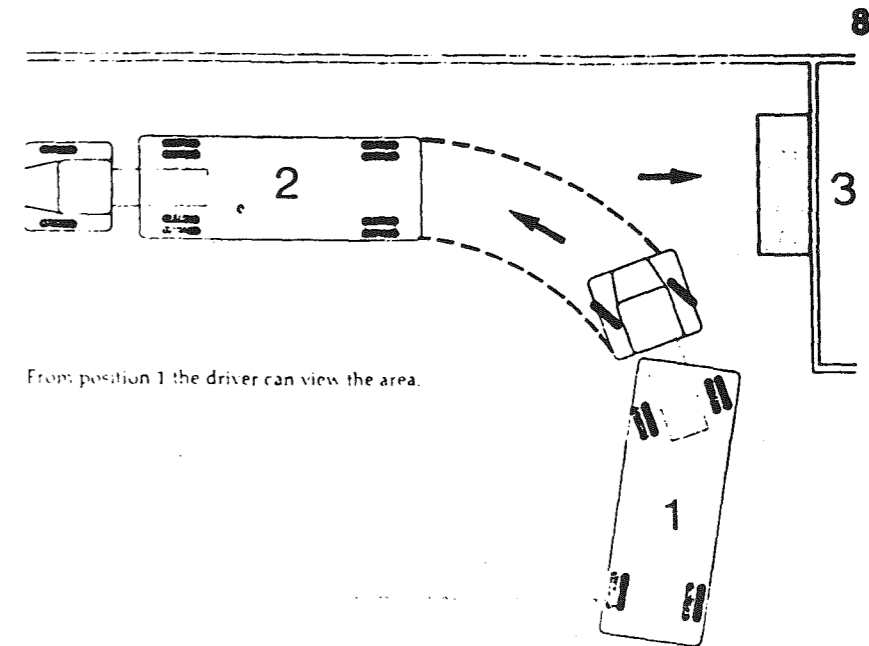

From position 1 the driver can view the area.

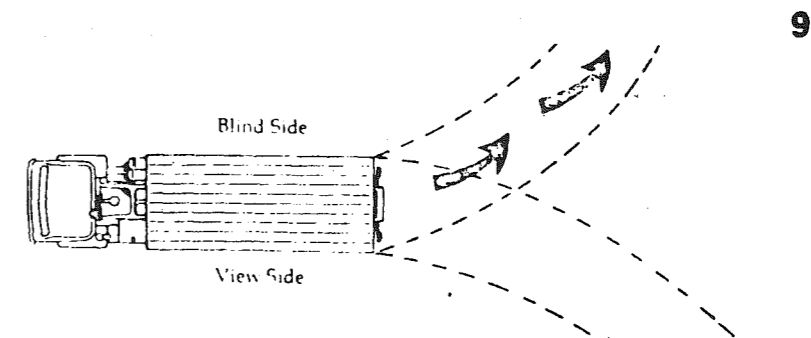

4. Don't back the vehicle to the blind side when it is possible to back to the view side.
5. Always back out of traffic rather than into traffic. The left driver in Diagram 10 has backed out of traffic. When he leaves the laneway, he will be able to observe traffic readily. The right driver in Diagram 10 has taken the easy way out of traffic, but now faces the problem of backing into traffic to leave the laneway.



6. Before backing a vehicle without a guide, you must:

1. Step out of the vehicle and look at the backing area for hazards.
2. Check for clearances and obstacles above, below, to the sides, to the rear and to the front of the vehicle.
3. Enter the cab; if there is no guide present, sound the horn before moving. Observe both mirrors while backing dead slow. If the backing distance is long, stop at intervals and recheck behind, above, below, to the sides, and ahead. Rather than making it one long backing manoeuvre, it is safer to make it a series of short backing manoeuvres.

A human life is worth more than the few extra moments it takes to be sure the way is clear.

LOADS AND UNLOADING

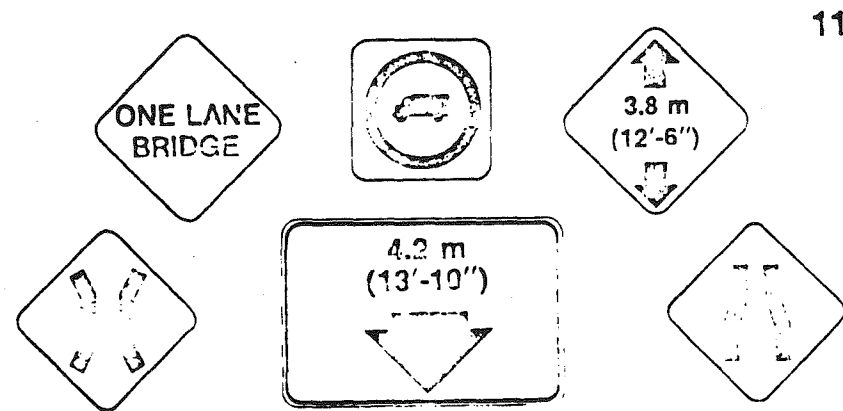

VEHICLE DIMENSIONS

Vehicles are limited to height, width, length and weight in accordance with the Northwest Territories Large Vehicle Control Regulations. Provisions are made for the issuance of permits for the movement of vehicles carrying over-size or over-weight loads. Regardless of licensing or permits issued, you must obey all posted signs which list the dimensions or weight of loads on any portion of the highway.

To assist you in avoiding damage to your vehicle and its load, and possible injury to other users of the highways, you must be alert to warning signs.

HEIGHT

The maximum height of a vehicle on highways is 4.2 m (13' 6") unless otherwise expressed in a permit.

You must know the total height of your vehicle and load at all times.

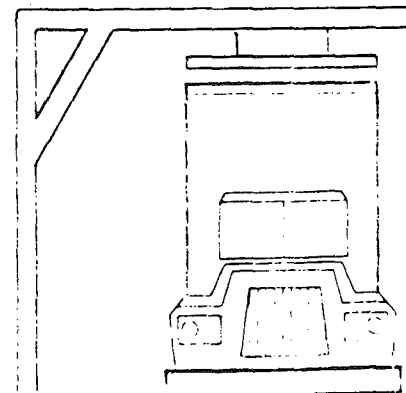

Special attention should be given for low overhead clearance which may not be posted. A few examples of such hazards are:

- underpasses and tunnels;
- fire escapes in alley-ways;
- boulevard tree limbs overhanging the roadway;
- service station and store canopies;
- low wires across residential driveways;
- repair shop and warehouse doors.

WARNING: During winter months, a snow build-up on the road surface can reduce overhead clearance.

OVERHEIGHT

On all Territorial Highways, a permit is required when the height exceed 4.2 m (13' 6").

In general, permits for overheight will be restricted to non-divisible loads and loads deemed to be impractical to divide. The overhead clearance on bridges and signs determines the maximum height allowable on a permit.

LENGTH

The legal lengths of vehicles allowed on provincial highways vary according to the type of vehicle. In the Northwest Territories the maximum vehicle lengths, unless otherwise expressed in a permit are:

1. for a vehicle other than a semi-trailer unit or passenger carrying motor vehicle with three axles a length of 12.5 m (45 feet);
2. for a semi-trailer unit a length of 20.m (65 feet);
3. for a combination of vehicles a total length of 21.5 m (75 feet), A and B trains.

OVERLENGTH

Permits are available for non-divisible loads and loads deemed to be impractical to divide.

WARNING: The driver of a truck which has an "overhang" over the rear axle must exercise caution in narrow roadways and alley-ways when negotiating tight turns. Allowances must be made for the "overhang" to avoid striking objects such as poles, parked cars, buildings, etc.

WIDTH

The maximum legal width, unless otherwise expressed in a permit for a vehicle and its load on a highway is 3.05 m (10feet).

WARNING: Caution must be exercised by drivers of overwidth vehicles at narrow bridges, defiles, and road construction areas.

OVERWIDTH

Overwidth permits are available for non-divisible loads, and loads deemed to be impractical to divide.

OVERWEIGHT

Overweight permits are restricted to non-divisible loads and loads deemed to be impractical to divide. Overweight permits are subject to the following conditions:

- (a) maximum of 500 pounds for each inch width of tire on any wheel or group of wheels;
- (b) maximum of 40,000 pounds on a tandem axle;
- (c) maximum of 22,000 pounds on a single axle;
- (d) the foregoing does not apply when a specific highway is under weight restrictions.

WEIGH SCALES AND ENFORCEMENT

The weigh scale is located in Enterprise, N.W.T. Signs are posted in advance of the scale for the information of drivers. The axle or axle groups are weighed, the tire size and the dimensions of the vehicle and its load are checked.

Whether the scales are permanent or portable, drivers must report as directed by the posted signs or upon the request of persons duly authorized. All personnel managing the weigh scale are Traffic Officers, and are empowered to enforce various N.W.T. Statutes and Regulations pursuant to these Statutes.

PERMITS

Before undertaking the transportation of oversize loads (overwidth, overheight, overlength, overweight) or movement of oversize vehicles, the driver must ensure he has the necessary permits. Permits for Territorial highway movement are issued in accordance with the Vehicles Ordinance and the Large Vehicle Control Regulations.

The conditions of the permit may prescribe the use of a pilot car, flags, signs or lights to be provided by the person to whom the permit is issued.

PILOT CAR REQUIREMENTS

A pilot vehicle may be required depending on the width of the driving surfaces and other topographical features on the route involved.

When a pilot vehicle is required, it shall precede the towing vehicle by 1,000 feet to 1,500 feet, while the trail vehicle, when required, shall follow the towed vehicle at a safe distance not to exceed 1,000 feet, but shall leave sufficient space to enable a passing vehicle to enter and occupy that space without danger.

Pilot vehicle and/or trail vehicle shall carry a "WIDE LOAD" sign mounted on top of the cab and shall conform with Illustration Number 1.

This sign shall be designed to mount on car top carriers or equal surfaces. It shall have two positions, upright when in use and folded flat on the carrier when not in use.

This sign shall be clean at all times

SIGN SPECIFICATIONS FOR PILOT VEHICLES

ILLUSTRATION 1

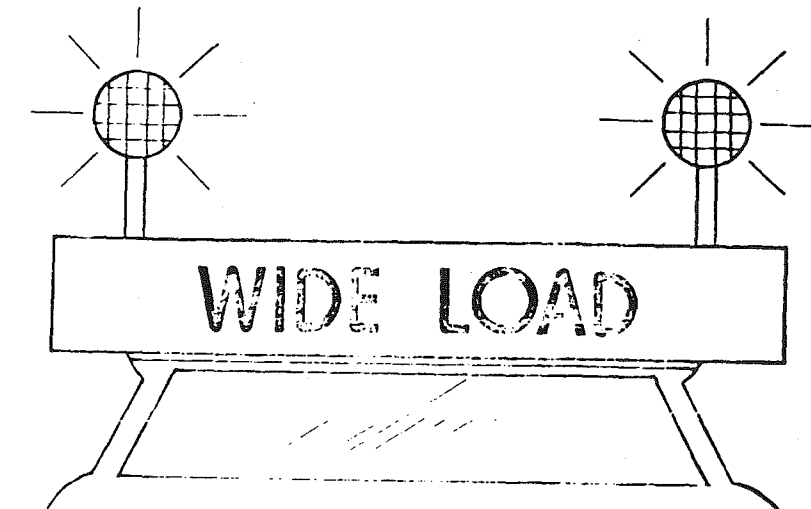

CARRIAGE UNIT
Car Top Carrier Type of Unit
of Adequate Design

ABOUT LOADS AND LOADING

WEIGHT DISTRIBUTION

The weight distribution of a cargo has a definite bearing on the handling characteristics of the vehicle, as well as the life of the tires, frame, springs, axles, and bearings.

Even though the total load may not be over the total carrying capacity of the vehicle, poor distribution of weight could be overloading an axle or set of tires.

Undue stress could be placed on the frame resulting in permanent damage and steering mis-alignment.

Distribution of weight will depend on the nature of the load. The loading of one piece of cargo which comprises the full load will present different problems from a load made up of a number of pieces of cargo.

The examples shown in the diagrams may be referred to as a general rule for loading but do not cover all situations which the driver may encounter.

RIGHT

WRONG



14

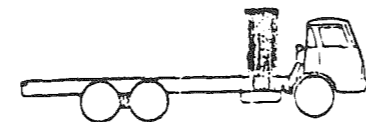

A heavy concentrated load should be placed near the rear end on its long side if at all possible. Most of the load should be over the rear axle to get proper tire loading and eliminate bending of the frame.

A very heavy concentrated load should not be loaded against the cab as the distribution of load may cause the frame to bend, perhaps permanently. It will also overload the front tires and may even cause a blowout on a worn tire. Hard steering will also result and the load may be top heavy.

15

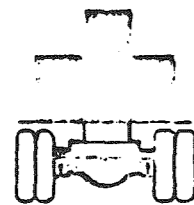

16

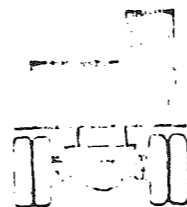

This loading distributes an equal weight on all rear tires and eliminates twisting and stress on the frame. Uniform crosswise loading also prevents axle housing and wheel bearing overloading.

A very heavy load should not be loaded on one side. This overloads one spring and the tires at that side. This loading could be bad enough to allow the brakes to lock on the wheels at the light side and cause flat spots on the tires or a skid on a wet surface.

17

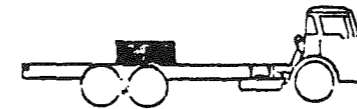

18

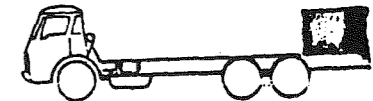

The proper place for the concentrated load illustrated is just ahead of the rear axle with the longest side on the floor.

This type of loading should never be permitted. The frame bends, the rear tires are very much overloaded, and enough weight is taken from the front tires to make steering almost impossible.

19

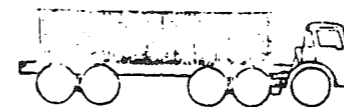

20

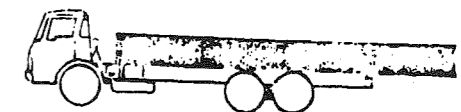

A tractor trailer combination is the proper vehicle for use in service like this. By using the proper vehicle, damage to the truck and tires, and even serious accidents, may be avoided.

This type of loading results from the use of the wrong vehicle for the job. On rough roads, such loading can result in an actual pivoting of the truck on its rear wheels, taking the front wheels entirely off the road.

21

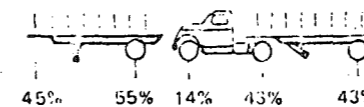

APPROXIMATE DISTRIBUTION OF TOTAL WEIGHT - VEHICLE PLUS PAYLOAD.

Trailers are also designed for uniform load distribution, as shown previously. The fundamental difference between loading trailers and trucks is; in the case of trucks, the average design provides for about 90% of the payload on the rear tires and 10% on the front tires. In the case of trailer, the payload should be distributed equally between the rear tires and the fifth wheel which transfers its load to the truck tractor.

WRONG

These examples are obviously wrong. In the case of the first trailer, the heavy load at the rear is overloading the rear trailer tires. There is practically no load on the fifth wheel, and the truck tractor rear tires would certainly slip and wear away rubber. Braking distribution would also be very uneven. Tail gate loading, of course, should never be practised, even in the interest of speed, as it puts a severe strain on the equipment, and frequently results in serious accidents.

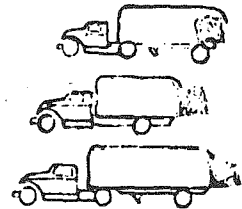

The load should be centered to give the proper wheel load distribution. The average single unit truck has a central weight distribution point midway between the rear of the cab and the tail gate. The average semi-trailer type truck has a central weight distribution point at approximately the middle of the trailer.

SECURING LOADS

Secure the entire load to prevent shifting or loss of any portion of the load. Periodic checks must be made to ensure lashing ropes or binder cables have not become slack or chaffed.

When hauling such loose materials as wood chips, paper, refuse, gravel and stones, etc., you should make certain that no part of the load is dislodged; covered to prevent dangerous driving situations for those following behind you.

Often the wind velocity is strong enough to force substantial sized stones to fly out of open boxes and smash windshields. The stones and other loose materials can cause accidents behind and to the sides. As well, littering is an offence chargeable to the driver and owner of the vehicle.

SIDE LEDGES. These are often forgotten and should be cleaned before starting off.

SPECIAL CARGOS

Every vehicle transporting any explosive should display a sign on each side and the front and rear, with the word "Explosives" in letters not less than six inches high on a background of sharply contrasting colours.

The vehicle should be equipped with no less than two fire extinguishers, filled and ready for immediate use and placed at a convenient point on the vehicle. Drivers of vehicles used for the transporting of explosives, flammable, combustible, corrosive or toxic liquids compressed gases, must ensure that the transporting of such commodities is in compliance with the Vehicles Ordinance and Explosives Act (Canada).

COUPLING A TRACTOR AND TRAILER

Before coupling the semi-trailer, you should inspect the condition of the king pin as well as the king pin plate. Also see that the wheel chocks are firmly in place behind the trailer wheels to prevent the trailer from moving.

The trailer is now ready to be coupled:

1. Make sure the fifth wheel jaw is open and the wheel horns are tilted down.
2. Slowly back the tractor squarely up to the approach plate of the trailer. DO NOT hit the plate.
3. Check height of semi in relation to the fifth wheel. Adjust the height by use of the trailer landing gear.
4. Connect the light cord and both air hoses to the trailer. Red to emergency and Blue to service.
5. Check alignment of king pin and fifth wheel on tractor.
6. Check that cargo in trailer is secure, and that no one is inside the trailer or behind it.
7. Open tractor protection valve and charge trailer with air. Apply trailer brakes using hand control.
8. Back slowly under the trailer until fifth wheel engages king pin.
9. Make sure coupling is secure by pulling tractor ahead slowly but firmly with the trailer brakes set. Do not move trailer as this may cause damage to the landing gear.
10. Apply parking brake and release trailer brake.
11. Visually check to see that the jaws of the fifth wheel are properly locked around the king pin, and the safety lock is in position.
12. Wind up landing gear fully replacing handle in the stowage bracket.
13. Check trailer sliding tandem lock pins are in position.
14. Check tractor sliding fifth wheel locking device is secure.

UNCOUPLING A TRACTOR AND TRAILER

1. Whenever possible, spot a semi on a level area in such a way that the units can be uncoupled in a straight line.
2. Apply the tractor protection valve.
3. Block wheels of semi to prevent it rolling.

4. Wind down landing gear.
5. Release fifth wheel locking handle.
6. Uncouple air brake hoses and light cord.
7. Pull forward slowly till tractor is clear of semi.

"TRAIN" OR "PUP-TRAIN"

To handle increased weights allowable under axle weight loading, many trucking operations have gone to the "train" or "pup-train" vehicle combination. In this type of combination, another trailer is pulled behind the regular tractor-trailer by means of a "converter dolly".

Drivers on train operation will discover that new skills are required for safe operation as well as an understanding of the equipment operation and hook-up. More than ever, you must be ready to adjust for changing conditions well ahead of time in order to take defensive or appropriate action to avoid trouble.

Power should always be applied when pulling on a straight stretch while under way (a steady pull, as opposed to intermittent application and reduction of power) with a small amount of reserve power always available. In the event that the rear trailer starts to fishtail or whip, apply trailer brakes lightly and increase power.

Drivers in "train" operations, as well as those driving semi-trailers, should avoid sudden lane changes or turns and speeds too fast for conditions as these actions can result in severe whipping or possible jackknife situations.

Regular vehicle checks should be made of the complete unit paying particular attention to the hook-up of the rear trailer, including:

1. the hitch on the rear of the lead trailer
2. the safety catch on the hook
3. the safety chains or cables
4. airlines between the trailers are secured and not allowed to sag down too low.

HOOKING UP A "TRAIN" OR "PUP-TRAIN"

1. Spot the rear trailer and set trailer brakes.
2. In front of the rear trailer, position the dolly converter so that it is in line with the king pin.
3. Hook up the tractor and lead trailer according to previous tractor-trailer hook-up instructions.
4. Back the tractor and lead trailer in line with and up to the converter dolly.

5. Before hooking up to the converter, a thorough trailer hitch inspection should be made. Watch for cracks, or breaks in the weld, loose bolts, weak lock springs, and bent or distorted crossmembers where the trailer hook is attached.
6. Hook and secure the converter dolly tongue to the pintle hook by hand. Fasten safety latch and chain. Ensure that safety pin is fastened (if so equipped). This is extremely important! This action will ensure the high degree of safety the trucking industry maintains, not only for themselves, but for other users of highways as well. "Train-drivers" should make it a point to check the safety latch on trailer hitch each time they stop for a vehicle check.
7. Safety chains and cables should be inspected before being attached. When fastening to lead trailer, they should be crossed so that if the converter dolly tongue breaks loose, it will be held suspended off the roadway while the driver attempts a safe stop.
8. Connect the air hoses between the two units, ensuring that all air lines, especially on the converter dolly, are well secured and not sagging too low.

Some companies that operate equipment with brakes on the converter dollies have applied coloured tape to the air lines in order to identify the service and emergency lines, thereby eliminating the possibility of improper hook-up.

CONNECTING VEHICLES

When a coupling device is used (other than the fifth wheel coupler of a semi-trailer unit), an auxiliary chain or metal cable of equal strength to the coupling device must also be used.

Swerving and Whipping - the trailer must not swerve or whip unreasonably when being towed by a motor vehicle.

If the trailer whips or swerves, slow down and stop to determine the cause.

PRE-TRIP VEHICLE INSPECTION

It is necessary to inspect your vehicle and your equipment, no matter how efficient and thorough the maintenance policy of a company or vehicle owner may be. Critical parts and components wear out and may fail to operate properly during a trip. The result could be a serious accident or a minor one; which it will be no one can predict. As a driver, you should know which equipment must be inspected before and, periodically, during a trip. You must be able to determine if any equipment or component is showing signs of failure or improper operation.

The investment of the few minutes required to check a vehicle before starting out will often prevent you from having costly delays enroute, and reduce the risk of accidents resulting from mechanical failure. Carrying out an efficient and thorough pre-trip inspection within a minimum of time can be done by following the systematic check procedures explained in the following pages.

It is an offence under The Vehicles Ordinance to drive or permit the driving upon a highway of any vehicle when part or parts of its equipment are defective or inoperative.

THE SCHOOL BUS

A "School Bus" as defined in the Vehicles Ordinance, means a motor vehicle used for conveyance of students to or from school by or under a contract with the authority in charge of the school.

EQUIPMENT

No person shall drive a vehicle registered as a school bus unless the vehicle is equipped, in addition to safe standard automobile equipment, with:

- a) an approved fire extinguisher, axe, first aid kit and flares as required by the Large Vehicle Control Regulations;
- b) seats which are safe and comfortable, and securely attached to the vehicle;
- c) heaters and ventilators which are adequate for safety and comfort;
- d) an exhaust system which meets the requirements of the Large Vehicle Control Regulations.

RULES FOR SCHOOL BUS DRIVERS

1. A school bus must come to a full stop at all railway crossings.
2. The school bus driver must not leave the vehicle until the motor is stopped, ignition key removed and the brakes set.
3. The school bus driver must not enter a garage or service station while carrying passengers.
4. The school bus driver must not back his vehicle on school grounds or at a bus stop, without assistance or direction from a responsible person.
5. The driver of a school bus, when about to stop to load or discharge passengers, shall activate the alternating flashing red warning lights in sufficient time to provide a reasonable warning to other vehicles and shall keep them activated during the entire process of loading or discharging passengers.
6. The headlights and tail lights of a school bus should be illuminated at all times while transporting children.
7. All buses must be kept in a sanitary condition.
8. All tools and equipment must be securely fastened and must not interfere with aisles, seats or exits.
9. Any commodity liable to endanger the safety of passengers must not be carried on a school bus.

10. The owner of a school bus shall have the vehicle inspected twice in each year by a mechanic who shall furnish to an inspector a mechanical certificate. Forthwith after each such inspection, the owner shall have the school bus inspected by the inspector who shall file a safety certificate.
11. The school bus driver should not consume any intoxicating liquor prior to driving a school bus.
12. Every school bus driver should:
 - a) maintain discipline among the passengers;
 - b) exercise due caution when loading or discharging passengers;
 - c) ensure that each passenger discharged has reached a place of safety before moving the vehicle;
 - d) when loading or discharging passengers at a school, stop the school bus in a position which permits the passengers to enter the school grounds without proceeding across a public highway.

PRE-TRIP INSPECTIONS - ALL SINGLE UNIT VEHICLES

1. ENGINE COMPARTMENT

- Check oil and coolant levels.
- Check all belts for cracks and adjustment.
- Check hoses and connections for fuel, oil and coolant leaks.

2. IN CAB

- Check driver's seat for adjustment.
- Set parking brake, Check mirrors for security and cleanliness.
- Shift transmission to neutral. For diesel, check engine stop control for proper position and be certain it is set to the run position.
- Start engine and check oil pressure, charging rate, unusual engine noises.
- Check operation of horn and windshield wipers.
- Check windshield and windows to left and right for clear visibility (Clean if necessary).
- Turn on all lights, operate left turn signal.

3. WALK AROUND VEHICLE

- Check headlights, front clearance lights, left front turn signal.
- Check wheels and tires on left side of vehicle for security (wheel lugs), tread wear and inflation.

- Check side clearance lights, and reflectors, at rear of vehicle.
- Check tail lights, licence plate light, left rear turn signal and rear clearance lights.
- Check rear doors for security (or tailgate).
- Check wheels and tires on right side of vehicle.
- Check side clearance lights and reflector.
- Switch headlights to other beam and check operation.
- Switch to right turn signal and check operation, front and rear.
- Apply brakes and have helper check operation of brake lights.
- Check four-way flashers (if equipped).

4. ENTER CAB

- Release parking brake.
- Check clutch action.
- Move vehicle ahead.
- Apply brakes, check operation.
- Check steering for excessive slack.
- With engine running, check underneath for exhaust and fluid leaks.

5. EMERGENCY EQUIPMENT

- Flares and flags.
- Fire extinguisher.
- First Aid kit and axe.

PRE-TRIP INSPECTION AIR BRAKE VEHICLES

In addition to the all vehicle pre-trip inspection already described, carry out the air brake inspection as outlined in the Air Brake Manual.

PRE-TRIP INSPECTION, VEHICLES EQUIPPED WITH VACUUM ASSISTED BRAKES

In addition to the all vehicle inspection, the following is carried out:

IN CAB:

- Start engine and warm up.
- Depress foot brake firmly, engine should not stall.

- Stop engine.
- Apply foot brake and start engine. Brake pedal should draw down slightly if booster is operating.

PRE-TRIP INSPECTION, BUSES OTHER THAN SCHOOL BUSES

In addition to the all vehicle inspection, the following is carried out:

- Check all interior lights for operation.
- Check aisle and stairwell lights.
- Check all seats and hand rails for security.
- Check operation of emergency door from inside and outside.
- Check service door control.
- Check operation of heater and defroster.
- Check interior for loose objects.

PRE-TRIP INSPECTION, SCHOOL BUSES

In addition to all vehicle inspection, the following is carried out:

- Check operation of warning lights.
- Check for first-aid kit.
- Check for School Bus Inspection Certificate.
- Check emergency door warning system.
- Check operation of heater and defroster.

IN-SERVICE INSPECTION

Vehicles used in "over the road" operations should be inspected at regular intervals throughout the trip. At a suggested interval, for example, 150 miles, you should stop the vehicle, clear of the travelled portion of the road, and check:

- Wheel nuts for tightness;
- Tires for condition, inflation and overheating;
- Coupling devices;
- Security of load;
- Operation of all lights.

PRE-TRIP INSPECTION TRAILER - SEMI-TRAILER

- Ensure king pin is locked in fifth wheel (semi-trailer).
- Check pintle hook is secure and safety chains on (full trailer).
- Check that air brake glad hands are correctly joined.
- Check light cord is properly connected.
- Check that landing gear is wound right up and handle stowed.
- Check all wheels, wheel nuts for security.
- Check tires, inflation, tread wear.
- Check all lights for operation.
- Check reflectors.
- Apply brakes and check for operation and air leaks.
- Move vehicle forward and check trailer brakes.

MIRRORS

Before starting a trip, it is your responsibility to be certain your mirrors are clean, in good condition, tight and properly adjusted, and you should see that they are maintained that way throughout the trip.

Operators of Class 1, 2, and 3 vehicles must depend on their mirrors to a far greater extent than drivers of passenger cars, in order to observe traffic conditions behind and while manoeuvring. It is vital that these be maintained in good condition at all times. Some drivers have a convex mirror which affords the operator a much better and clearer view of traffic immediately alongside and behind him than the ordinary mirror. This is a good practice and you should learn to use the convex mirror whenever manoeuvring in confined spaces, or where there is a chance of other traffic or pedestrians getting in the way.

TIRES AND PRESSURE

The degree of control you have over a vehicle depends on the amount of traction between the tires and the road surface.

Tire pressures and tire conditions are important factors in safe vehicle operation.

Rotation of the tires under load causes a flexing of the casing. This flexing causes internal friction which generates heat. Tires dissipate heat to the atmosphere, and if the correct tire size with the proper air pressure is used according to the load carried, the heat build-up will reach a heat balance temperature for which the tire is designed. The cooling rate will be in balance with the heating rate.

If the tires are under-inflated, overloaded for their size, and subject to too much speed, the flexing action is increased. This will result in a heat build-up rate exceeding the cooling rate and the tire will overheat. As the

heat builds up, it causes air pressure within the tire to increase to pressures higher than that for which the tire is designed.

If the tire temperature reaches 225 degrees Fahrenheit (125.6 degrees C) or greater, the tire will deteriorate because it is nearing the vulcanizing temperature of around 290 degrees Fahrenheit (161.1 degrees C).

BLEEDING PRESSURE

If the tire has the correct pressure when it is cool, the heat build-up which is normal will cause the pressure within the tire to increase and reduce the amount of wall flexing, controlling the heat build-up. If you bleed the pressure down while the tire is warm, you upset the cooling balance and the tire will generate more heat. NEVER BLEED DOWN A WARM TIRE. Pressure should be checked and adjusted when the tires are cool.

TIRE PRESSURE AND TIRE WEAR

Correct tire pressure is an important factor of tire wear, as well as steering control. An over-inflated tire will result in centre tread wear. Over-inflation of a tire also results in less tread surface being in contact with the road surface, which reduces the amount of TRACTION.

An under-inflated tire results in wear on the outer edges of the tread surface. On a wet road surface, an under-inflated tire will not squeeze the water out from under the tire surfaces as effectively as a correctly inflated tire will. If the tire is under-inflated, it has more chance of riding upon a film of water causing hydroplaning.

PROFESSIONAL DRIVERS PRACTICES

PUTTING A VEHICLE INTO MOTION (GASOLINE POWERED) (NOT GOVERNED)

Start in low gear, using only enough power to place the vehicle in motion. Don't rev the engine up in this gear to maximum RPM, but shift to the next higher gear. Progress through each higher gear, increasing vehicle speed and engine RPM together. As each shift is completed, engage the clutch smoothly to avoid shock to the drive train, load and passengers.

PUTTING A VEHICLE INTO MOTION (GASOLINE OR DIESEL, WITH ENGINE RPM GOVERNED)

Start in low gear, and accelerate to governed RPM. Shift to next higher gear and progress through each higher gear, shifting when engine reaches its governed RPM. As each shift is completed, engage the clutch smoothly to avoid shock to the drive train, load and passengers.

USING AN ENGINE TACHOMETER IN SHIFTING

Most engine manufacturers recommend 85% of governed engine speed to be the most efficient for normal operation of a unit. Knowing the governed speed, it is a simple calculation that will give the most efficient operating speed.

When driving, a glance at the tachometer will indicate the necessity of a change in gear.

All transmissions have a known "split" between gear ratios and familiarization with the transmission in use will give a driver the drop in revs required to make a clean shift.

Shifting down is also made easier by the use of tachometer. In reversing the above procedure, knowing the "split" or RPM difference between the gears, a driver will be able to increase the engine revs to a clean downshift.

The following diagrams will show typical gear shift patterns:

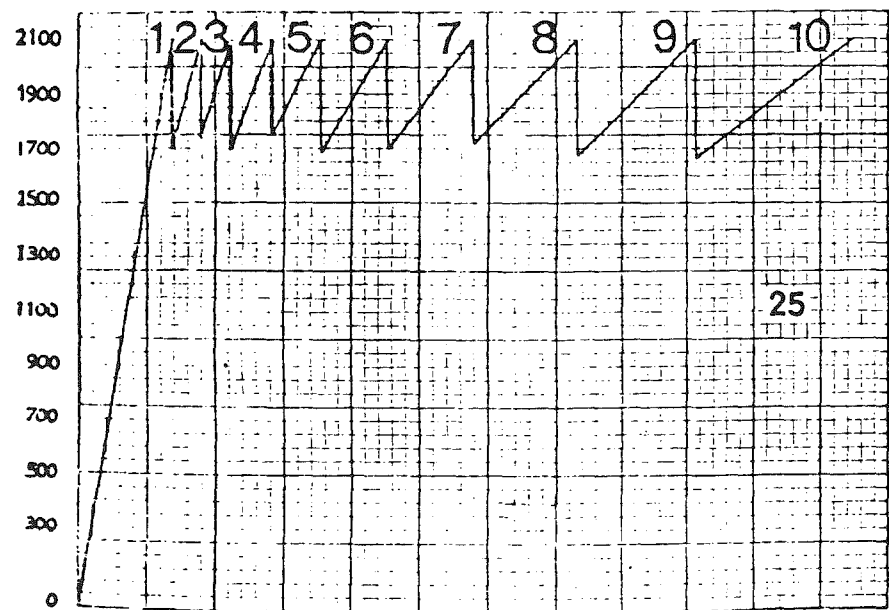
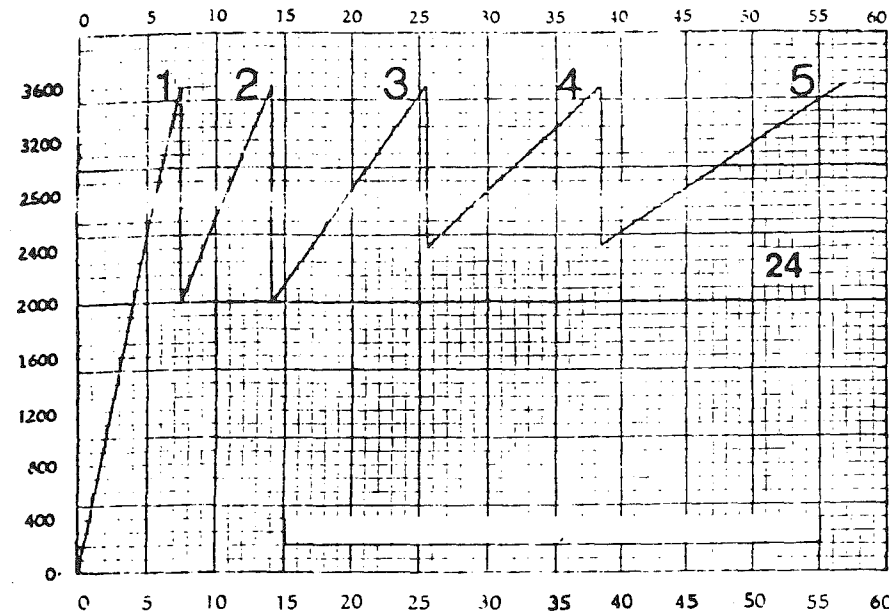

SHIFTING UP THROUGH THE GEARS (MAIN TRANSMISSION)

In each gear, sufficient speed must be built up to avoid labouring the engine in that gear; speed must be sufficient so that the engine will not be laboured when the next higher gear is reached. Double-clutching must be used on most manual-shift truck transmissions. Shifting is faster and smoother when the double-clutch procedure of depressing the clutch twice with each change of gears is used.

SHIFTING DOWN

Be alert to changing conditions which may require reduction of speed and shifting to lower gear. Don't wait until the engine starts to labour before shifting down. For dangerous down grades, gears should be down-shifted before passing the crest of a hill, since it's dangerous to down-shift past that point. If you miss a gear, you're in trouble.

In addition, if your brakes fail on a level road, you should shift to a lower gear and use engine compression to assist in stopping the vehicle. Your knowledge and ability to select and shift gears, as would be required in the normal operation of the vehicle, will be observed during the road test.

STEERING MANOEUVRES

STEERING FORWARD

The degree of sharpness a vehicle will turn depends on two factors: the TURNING RADIUS of the front wheels and the amount of OFF-TRACK of the rear wheels.

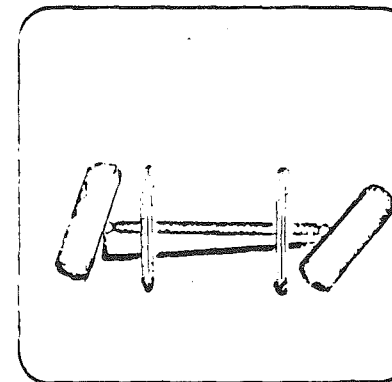

26

OFF-TRACK

The rear wheels of the vehicle do not pivot and therefore will not follow the same path as the front wheels. The greater the distance (wheel base) between the front wheels and the rear wheels of the vehicle, the greater the amount of "off-track". The off-track path is a shorter radius than the path of the front wheels.

TURNING RADIUS

The number of degrees the front wheels will pivot to the left or to the right varies in different makes and types of vehicles. The wheel on the inside of the turn must pivot sharper to travel on the shorter radius than the wheel on the outside of the turn.

27

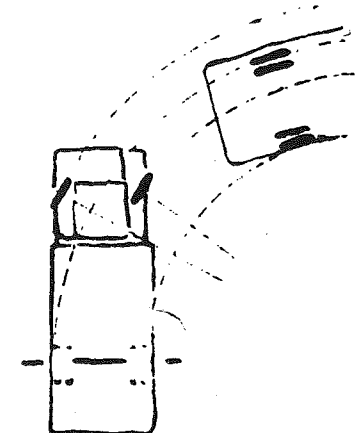

The combination vehicle such as a semi-trailer unit, has an off-track of the rear wheels of the tractor unit, and a greater off-track again by the rear wheels of the semi-trailer.

The combination unit of a truck-tractor and "pup" trailer has different turning characteristics than that of the semi-trailer type. These units have a turning radius and off-track pattern within each unit, but the amount of off-track is dependent upon the length of the draw bar and the wheel base of the units.

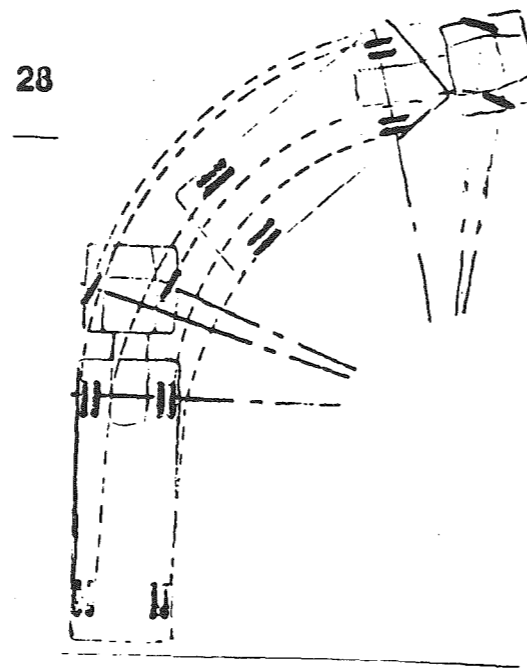

28

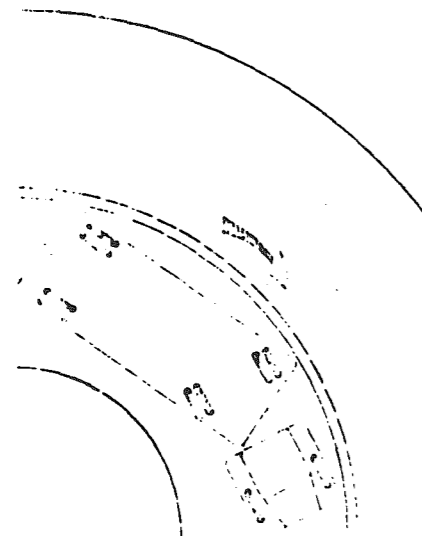

29

On the open highway, you must lead your turning arc of the front wheels in accordance to the sharpness of the curve and the amount of off-track of your vehicle. A curve to the right requires keeping the front wheels close to the centre line to prevent dropping the rear wheels off the pavement shoulders. A curve to the left requires keeping the front wheels close to the right edge of the pavement to prevent the rear wheel from crossing into the other traffic lane.

Negotiating narrow bridges which have a curved approach requires the driver of larger units to exercise caution and skill. You must be familiar with the amount of off-track of your vehicle and adjust your speed and approach accordingly.

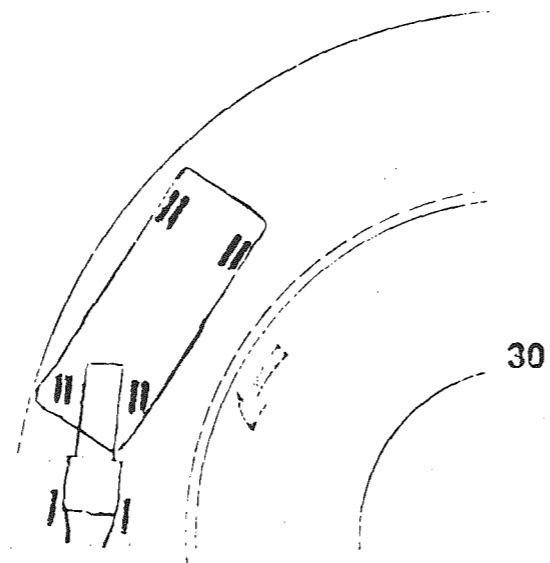

30

36

Right angle turns at intersections with vehicles which have an appreciable amount of off-track, requires you to lead your turning arc in accordance to the amount of off-track. Running the rear wheel of the unit over curbs and sidewalks not only causes tire damage but is also hazardous to pedestrians. Power poles, sign posts, or lamp standards mounted close to the curbing at intersections are fixed object hazards.

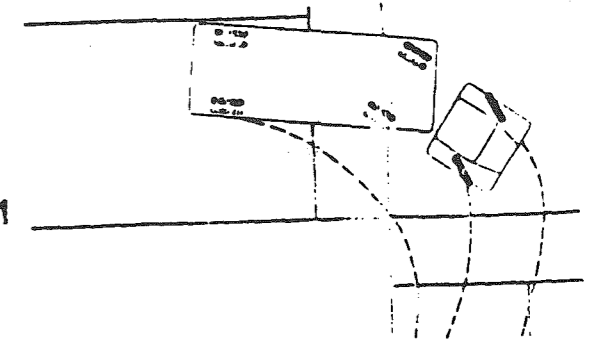

31

32

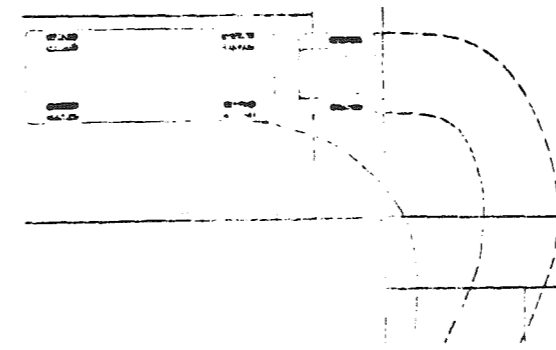

If the streets are narrow, it will be necessary for you to proceed well into the intersection before commencing your turn. It may be necessary to travel over the centre line of the street you are entering or into the second traffic lane. When it is necessary to do this because of the limited width of the street, you must use extreme caution and ensure you can make the movement in safety.

When it becomes necessary to "block" off the other traffic lane, for example an extra long trailer, narrow road, partially blocked street - ensure that smaller vehicles, motorcycles or cyclists are not attempting to proceed in on your right. The critical point is reached when the tractor is at the sharpest point of the turn in relation to the trailer, as the right rear view mirror vision is limited.

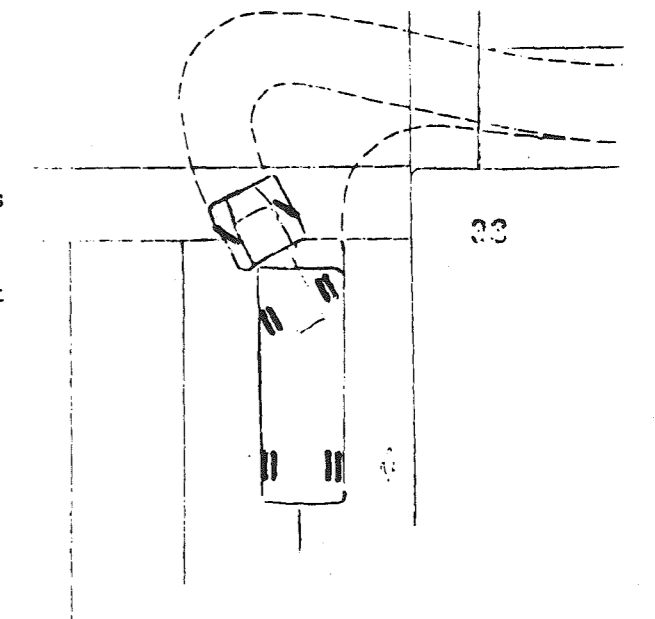

33

37

STEERING BACKWARD

The control of a single unit vehicle is maintained in the same manner as that of a passenger vehicle.

In backing a tractor with a semi-trailer, the front wheels of the tractor must be turned in a direction opposite to that in which it is desired to move the rear of the trailer.

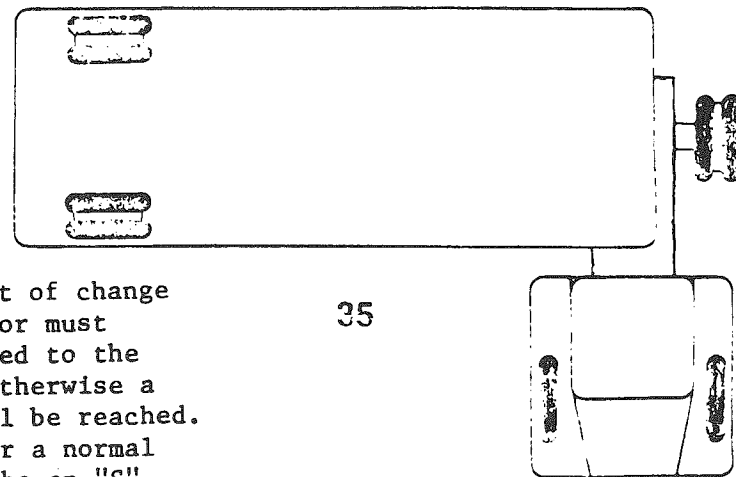
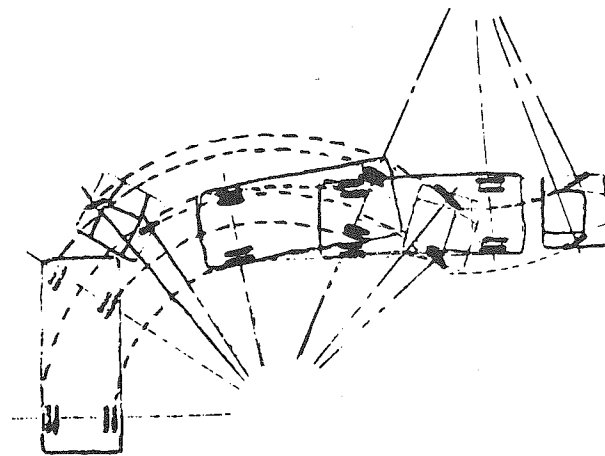

Depending on the amount of change in direction, the tractor must follow in a track related to the track of the trailer, otherwise a jack-knife position will be reached. The tracking pattern for a normal right angle turn would be an "S" shaped curve.

"U" TURN

It is not a recommended practice to make a U-turn. It is preferable that you drive around the block, or do so on wide, divided highways.

PASSENGER CARRYING VEHICLES

The prime consideration of the professional driver is the safe operation of his vehicle. This must take precedence over schedules or any other factor that might contribute to a less than safe operation.

The professional driver operating a Class 2 or Class 4 vehicle, in addition to his consideration to safety, must also be considerate of the comfort of his passengers.

The operation of buses requires the driver develop handling skills in accordance with the characteristics of the vehicle. A knowledge of the turning radius, amount of off-track of the rear wheels, overhang past the rear wheels and width of the vehicle, are important factors the driver must know to perfect his handling skill of the vehicle.

Many passenger accidents have been attributed to:

- Improperly parked at a loading zone;
- Picking up or discharging passengers when unsafe;
- Sudden stops or starts with standing passengers;
- Sharp turns at excessive speed;
- Improper operation of bus doors.

Accidents of this type are the result of improper operations by the driver and are PREVENTABLE.

RIGHT TURNS

In making a turn to the right, the driver must avoid running over or scuffing the curbing with the rear wheels.

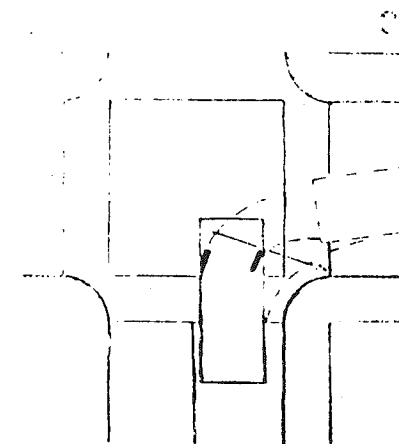

Executing a sharp turn to the right (particularly with a forward control vehicle) position the bus three to five feet out from the curb as you approach the intersection. Proceed straight until the curb line of the side street can be sighted through the front entrance door. (As shown in the diagram).

Entering the turn at a low speed requires less turning speed of the steering wheel, making a smoother turn with less exertion by the driver.

Right turns into very narrow streets may require that the driver proceed well into the intersection before commencing his turn. It may be necessary to travel over the centre line as the turn is made. When such movement is necessary, the driver must use extreme caution, and ensure that the movement can be made in safety.

LEFT TURNS

Left turns from a one-way street into a one-way street will require that the driver lead his turning arc in a similar manner as in the right hand turn, to avoid running over or scuffing the curbing with the left rear wheels.

LEAVING THE CURB

The driver should not rely only on the side mirror to check that traffic is clear before pulling out, but should in addition to the mirror, glance over his left shoulder to verify the way is safe.

Leaving the curb with a bus will require a signal be given by means of the signal lights, but the driver should not use the turn signal until he is prepared to proceed from the curb.

Leaving the curb with a bus which has an overhang over the rear wheels, requires the driver use caution to avoid striking pedestrians, poles, or sign posts which are located close to the curbing. Cars parked close to the front of the bus and vehicles approaching in the opposite direction are factors which the driver must assess before moving his vehicle.

PARKED CARS

Passing parked cars requires the driver be constantly alert for hazards; cars pulling out without warning, sudden opening of doors on the traffic side, or pedestrians stepping out from between cars.

WATCH FOR WARNING CLUES:

- Front wheels turned out.
- Exhaust from tail pipes.
- Drivers sitting behind the wheel.
- Brake lights.

SAFETY PROVISIONS

A driver of a passenger vehicle should not collect fares, or take on or discharge passengers while the vehicle is in motion, nor may he engage in unnecessary conversation with passengers while he is driving the vehicle.

DRIVER'S VISION

The driver's view ahead, and to the right and left, must not be obscured in any way, and he must at all times have full movement of his arms and legs, and ready access to emergency equipment. No passenger may sit to the left of the driver, and in the case of a sedan-type vehicle a maximum of two passengers, in addition to the driver, should be seated on the front seat, and then only if there remains adequate room for the driver to operate the vehicle safely.

STANDING PASSENGERS

Passengers are not allowed to ride on the running boards, fenders, or any part of the vehicle other than the seats.

In the case of a local transit vehicle, the driver should not permit passengers to stand to his right, so as to obstruct his view.

FIRE FIGHTING

Fighting a fire efficiently requires quick thinking and fast action based on training. All drivers should inspect daily the fire fighting equipment on their vehicle. Familiarizing yourself with types of fires that may occur on a particular vehicle driven, together with studying the following, may prevent the loss of your vehicle or personal injury to yourself.

1. Water spreads gasoline or oil fires. Use extinguishers, sand, or dirt, to smother.
2. Use chemical extinguishers only enough to smother flames; keep some in reserve for flare-ups.
3. Shut off switches and disconnect battery cables of vehicles involved in accidents to prevent fires caused by leaking fuel, etc.
4. Fires occurring on combination units; If you are sure you can do so safely, disconnect the tractor from the trailer and separate the units a safe distance apart.
5. Whenever possible, fight fires with the wind at your back (lessens the chance of asphyxiation).
6. Under-hood fires: don't throw hood open. Raise hood very slightly to fight the fire. If the hood cannot be raised, direct extinguisher from underneath vehicle or through radiator.
7. Have someone call the fire department whenever practicable. Warn others of the danger of explosion by gasoline or inflammable loads and to keep back a safe distance.
8. Don't risk your own life. Gasoline fires can spread rapidly and explode.

ABOUT FIRE EXTINGUISHERS

Multi-purpose dry chemical extinguishers marked (B.C.) extinguish grease, oil, gasoline and electrical fires. If the cylinder is marked A.B.C., it also will extinguish class "A" fires such as paper, cloth, etc. The operator can use this extinguisher without fear of the contents as to health hazard or bodily injury.

Carbon Tetrachloride on open flames generates phosgene gas which is dangerous to health. Avoid the use of this type of extinguisher in closed areas.

CO₂ extinguishers (carbon dioxide) - Don't remain in an enclosed space as there is danger of suffocating.

Methyl bromide extinguishers - this chemical may cause blistering of the skin. Rinse off with water if it comes into contact with the skin.

EMERGENCY VEHICLES

The driver of an ambulance, police vehicle or fire-fighting vehicle, when responding to, but not when returning from, an emergency call or alarm, or when in pursuit of an actual or suspected violator of the law, may

- a) exceed the speed limit;
- b) proceed past a red traffic-control signal or stop sign without stopping;
- c) disregard rules and traffic-control devices governing direction of movement or turning in specified directions; and
- d) stop or stand.

The driver of an ambulance, police vehicle or fire-fighting vehicle shall not exercise the privileges granted in (a), (b), (c) or (d) unless he is sounding an audible signal by bell, siren or exhaust whistle and is showing a flashing red light.

The driver of an ambulance, police vehicle or fire-fighting vehicle exercising any of the privileges granted in paragraph 1 and 2 shall drive with due regard for safety having regard to all the circumstances of the case, including,

- a) the nature, condition and use of the highway;
- b) the amount of traffic that is, on or might reasonably be expected to be on the highway; and
- c) the nature of the use being made of the ambulance, police vehicle or fire-fighting vehicle at the time.

The driver of an ambulance is deemed to be responding to an emergency call from the time he receives such call until he arrives at the destination of his passenger.

DUTIES OF OTHER DRIVERS

The Vehicles Ordinance requires that drivers of other vehicles must give the right-of-way to an emergency vehicle which is displaying a flashing red light or flashing white lights and is sounding a siren or other warning device. Such drivers are obligated to drive parallel to the right-hand side of the roadway, as close to the edge as circumstances permit and, where the vehicle is within an intersection, to clear the intersection and stop on the other side until the emergency vehicle has passed.

These laws were passed to assist operators of emergency vehicles to carry out their responsibilities with a minimum of delay. However, you should not presume that all drivers will comply with the law at all times. Sometimes, a driver has difficulty in identifying the direction from which an emergency vehicle is approaching, particularly at intersections, and he may inadvertently drive into your path. At other times, particularly during cold weather when all windows are closed, drivers have difficulty in hearing the siren and may not react as quickly as they might under more favourable conditions.

When roads and traffic conditions are severe, extra care is required. It is far better to take a few extra minutes to arrive at your destination safely, than to be delayed by an accident.

REPAIR VEHICLES

These are vehicles used to repair other vehicles or tow other vehicles. All repair vehicles should be equipped with a flashing or oscillating amber light. The flashing amber light should be in operation only when a vehicle is undertow. Again, because such vehicles are often used under emergency conditions, for example, at scenes of accidents, it is necessary that you use every precaution not to create a situation that could lead to a further accident.

You should remove derelict or damaged vehicles from the highways so that they do not obstruct the free passage of other vehicles and, in addition, clean up any debris that may be lying on the highway as the result of a collision.

TAXICABS

For the most part, vehicles used as taxicabs do not differ significantly in structure from ordinary passenger cars. The skills required to operate them are essentially the same as those required to operate any other kind of passenger car.

What makes the operation of a taxicab unique, however, is the fact that unlike any other vehicle, the driver is constantly exposed to the risk of collision. Generally, taxicabs are operated 24 hours a day in high traffic density areas. The average number

of kilometers travelled by a taxicab driver in the course of one year is approximately 64,000 or nearly four times the average distance driven by drivers of passenger cars.

Drivers of taxicabs have to contend with a multiplicity of problems.

Taxicab drivers are:

- frequently called to attend emergency situations;
- urged by their passengers to hurry in order to catch a plane or to attend a meeting for which they may be late;

The resulting pressures require that taxicab drivers have a high degree of skill in the operation of their vehicle and have a thorough knowledge of the street systems so that they can plan their routes quickly to their destination.

Examination of the driving records of taxicab drivers shows two things:

1. Some taxicab drivers have an exceedingly high incidence of accidents. This is attributable in part, to the high exposure rate mentioned earlier.
2. A more disturbing aspect reveals that taxicab drivers are frequently charged and convicted for speeding and failing to obey traffic control devices.

While the higher involvement rate in accidents may be somewhat understandable, it is difficult to justify why some taxicab drivers commit these offences with such frequency, causing them to lose, at times, their driver's licence and their job.

Studies have shown that it is virtually impossible to pick up time in heavy traffic areas. Experiments carried out in other cities have shown that the time saved by a driver driving as fast as traffic conditions allow and disregarding other regulations, compared to a driver driving within the speed limit and observing all traffic rules, is a matter of a few minutes, scarcely worth the increased accident risk or the possibility of getting a traffic ticket.

SUGGESTED PRACTICE FOR TAXICAB DRIVERS

It is a good practice to check the condition of your vehicle before taking it out for a day's work. If you detect any defects or inoperative equipment, you shouldn't take the vehicle out until the defect or inoperative equipment has been repaired. During the working day, if you detect any malfunction of the safety equipment, call your dispatcher at once and advise him of the nature of the defect. The vehicle should be taken in for repairs as soon as possible; if the defect is serious, you should not attempt to drive it. Have it towed instead.

THINGS YOU SHOULD KNOW

How can the driver anticipate a change in traffic signals as he approaches an intersection?

What conditions should the driver consider when deciding upon a safe driving speed?

In what way does the slow driver create a traffic hazard?

In what way does the fast driver create a traffic hazard?

What is the most effective way to deal with a "tail-gater"?

What is the surest method of reducing stopping distance?

What is meant by "The Danger Zone" of a vehicle?

What defensive measures can the driver take as he approaches any intersection?

If the weight of the vehicle is doubled, by how many times must the braking force be increased to stop the vehicle?

If the speed of the vehicle is doubled, by how many times must the braking force be increased to stop the vehicle?

If the weight and the speed of the vehicle is doubled, by how many times must the braking force be increased to stop the vehicle?

How many braking systems are required on every truck, truck-tractor or bus?

What determines the "safespeed" to proceed down any hill?

What is the purpose of an engine governor?

Are engine retarders more effective at low engine RPM or high RPM?

What should the driver do when it becomes necessary to drive his vehicle through water which is upon the highway?

Why should you avoid overtaking another vehicle when your difference in speed is only slight?

Why should you not signal another vehicle to overtake and pass you?

What action should the driver take when he is being overtaken by a small vehicle?

What is the advantage of "double clutching" when shifting gears?

To proceed down a steep grade, at what point should the driver gear down?

How can the driver determine the correct gear to select before descending a steep grade?

How can backing accidents be prevented?

What are the three steps a driver should take before backing a large vehicle?

What precautions must be taken by the driver before leaving his vehicle parked on a grade?

What is the prime factor which determines the amount of control the driver has over his vehicle in a curve?

What would be the effect on a vehicle which is travelling too fast in a curve?

What is the effect of applying "power" in a curve?

Why are accidents more likely to occur in intersections than in other areas of driving?

What is meant by the term "stale green light"?

How can the driver safely test for an "icy" road surface?

Why should a driver reduce the speed of his vehicle at night?

What precautions can the driver take to reduce the probability of night driving accidents?

When is the best time to check tire pressures?

Why should the driver avoid bleeding the pressure down on a hot tire?

Why is it dangerous to shift gears while the vehicle is crossing railway tracks?

If you become drowsy when driving, what is the best thing to do?

Why should water not be thrown on a gasoline, oil or grease fire?

What could the driver do if a fire started in a trailer being pulled by his vehicle?

What precautions should be taken when using a carbon tetrachloride or a CO₂ type fire extinguisher?

What determines the amount of off-track a vehicle will have?

What is the danger of allowing the rear wheels of the vehicle to cross over the centre line of the roadway when negotiating a left turn or curve?

What are the hazards of running rear wheels over curbs when making sharp turns to the right?

What precautions must the driver take before crossing the centre line of the roadway to negotiate a sharp turn right from a narrow roadway?

When it becomes necessary to "block off" more than one lane of traffic to negotiate a sharp right turn, what special precautions must the driver take?

What preventative measures should a driver take before entering a narrow bridge from a curved approach?

Why is it important that the driver know the height of his vehicle and load?

What are some of the low overhead clearance hazards that may not always be indicated by a warning sign?

Are all commercial vehicles required to report to weight scales?

What is required before oversize or overweight loads may be transported?

What must be used to mark the extremities of an overwidth load?

What could result from placing too much weight over any one set of wheels, or over any one axle?

Where should the majority of the weight of a load on a single unit truck be placed? Directly behind the cab, slightly ahead of the rear axle, or slightly behind the rear axle?

Should the majority of the weight of a load on a semi-trailer be placed directly over the fifth wheel, at a midway point of the trailer, or directly over the trailer axle?

If a load is allowed to escape from the vehicle, who can be held responsible; the driver or the owners of the vehicle?

What is the maximum legal width of a vehicle to be operated upon any highway?

How many "Explosives" warning signs must be displayed on a vehicle transporting explosives?

Who is responsible to ensure that fire extinguishers are filled and operable?

When a coupling device is used to join vehicles in combination (other than a fifth wheel) is an additional coupling device such as a chain or cable required?

When coupling a tractor to a semi-trailer, must the air lines be connected before, or after engaging the fifth wheel to the trailer pin?

How would you test to see that the fifth wheel jaws have locked to the trailer pin?

To uncouple a tractor from a semi-trailer, are the air lines unhooked before, or after separating the fifth wheel from the trailer pin?

Is it necessary to block the wheel of a trailer that is to be left for any length of time?

How can the brakes of an air brake equipped trailer be released, when no air supply is available (not spring brakes)?

What is the advantage of a regular pre-trip vehicle inspection?

What final test of the vehicle's braking system must the driver complete before placing his vehicle into service?

What items of the vehicle should a driver check periodically during the trip?

If a sign is posted to the advance of a down grade, warning drivers to stop and check the brakes of their vehicle, is it always necessary that drivers of large trucks do so?

Will the brakes of a vehicle become less efficient if they become overheated?

What is the first consideration of a driver who operates a vehicle used for the transportation of the public?

Is it important that the driver of a bus know the length, width and wheel base of his vehicle?

Is a passenger accident attributed to a sudden stop usually preventable?

What is the recommended method of handling the steering wheel on a sharp turn?

What is the advantage of entering a sharp turn at a low speed?

If it is necessary to cross over a center line or lane line to negotiate a sharp turn with a long wheel base vehicle, what precautions should the driver take?

In addition to checking the left side mirror, where should the driver of a vehicle look before leaving the curb?

What precautions must the driver of a bus take when leaving a parked position at which poles or sign posts are located near his vehicle?

Should the driver turn on the vehicle's signal lights before he is ready to leave the parking position?

What hazards should a driver expect when passing a line of parked vehicles?

What warning clues should the driver watch for when he is driving past a line of parked cars?

Should the driver collect a fare or make change while the vehicle he operates is in motion?

In a sedan type vehicle, how many passengers should occupy the front seat in addition to the driver?

Is it necessary to illuminate the entrance step or steps of a bus?

What action would you take if the public vehicle driven by you broke down or developed such defects so that to continue the trip would endanger the safety of the passengers?

What precautions must be taken when refueling public passenger vehicles?

How often is it necessary to test the brakes on a public vehicle?

How many braking systems are buses required to have?

How often must a school bus be inspected by a competent mechanic?

May the operator of any school bus allow any passengers to stand while the vehicle is in motion?

May the driver of a school bus set the vehicle in motion before every passenger is seated?

Should a person be allowed to board or leave a school bus except from the right side?

Should the driver of a school bus allow students to leave the bus other than at their regular stops?

When students are required to cross the roadway after leaving the bus, should they cross in front of the bus or in the rear of the bus?

Must the driver of a school bus be certain traffic has stopped in obedience to the alternating flashing lights before he permits the students to leave the bus?

Under what conditions may the driver of an emergency vehicle exceed a posted speed limit?