

# A Way of Life

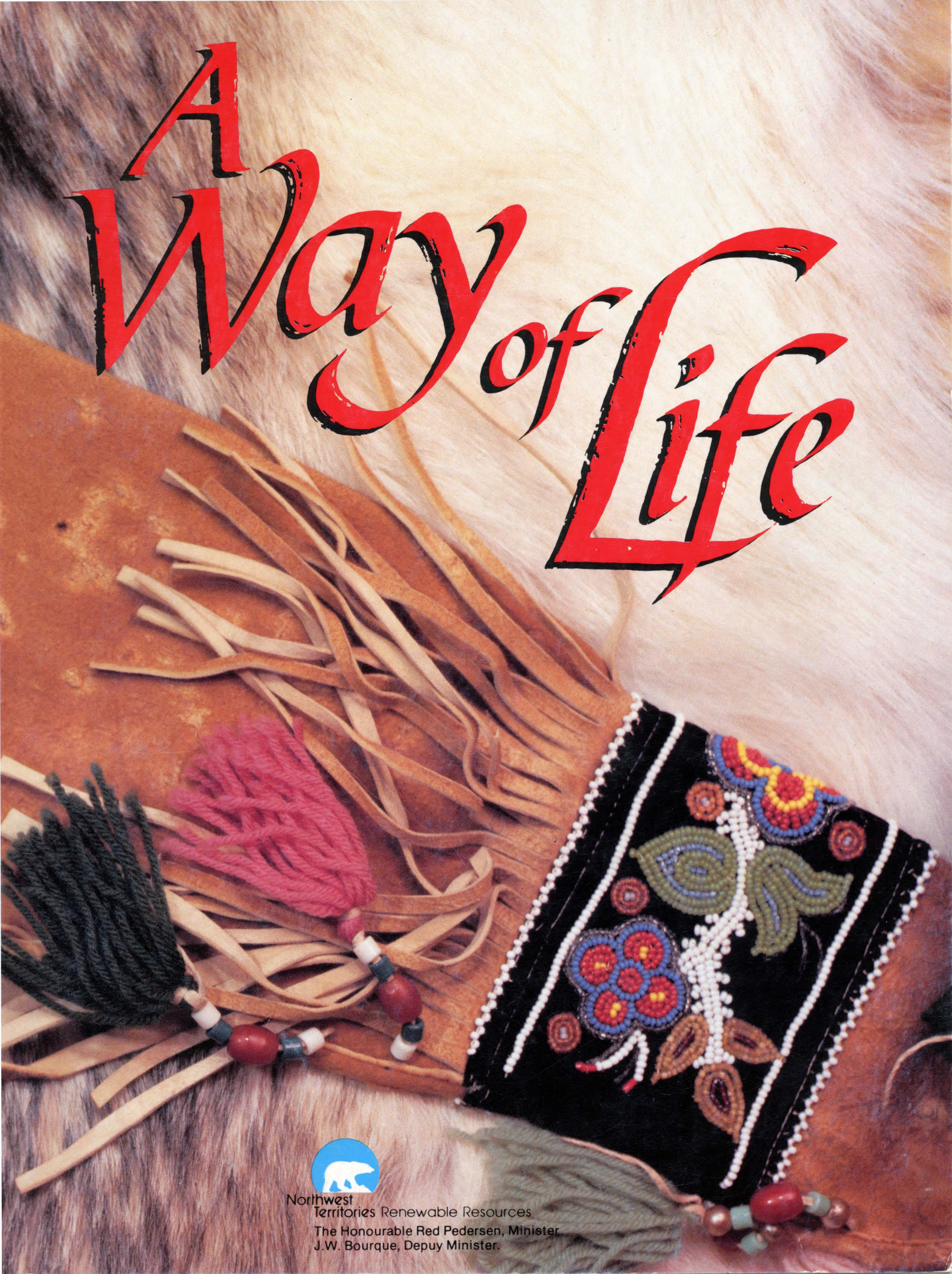

Northwest  
Territories Renewable Resources  
The Honourable Red Pedersen, Minister  
J.W. Bourque, Deputy Minister.



The rifle case shown on the cover is from the permanent collections of the Prince of Wales Northern Heritage Centre, Yellowknife, NWT.



*A  
Way of Life*







# A Way of Life

*Ed Hall, Editor*



Northwest  
Territories Renewable Resources  
The Honourable Red Pedersen, Minister  
J.W. Bourque, Deputy Minister.



---

---

Copyright © 1986 by:

Department of Renewable Resources  
Government of the Northwest Territories  
Yellowknife, NWT

All rights reserved. No part of this book may be reproduced or transmitted in any form by any means, electronic or mechanical, including photocopying, recording, or by any information storage or retrieval system, without permission from the publisher, except for brief passages quoted by a reviewer in a newspaper or magazine.

ISBN 0-7708-7146-1 \$7.50

Design: John Williamson

Illustrations: Esther Tennenhouse

Darrin Ouellette

John Allerston

Lettering: Rob Butler

Cover photo: Tessa Macintosh

Production: Outcrop Ltd.

Order from:

Department of Culture and Communications

Publications and Production Division

Government of the Northwest Territories

P.O. Box 1320

Yellowknife, NWT

X1A 2L9

---

---

# Contents

Acknowledgements	5
<b>Fur Trade in the Northwest Territories</b>	7
Profiles 1,2,3	30
<b>Making Snowshoes</b>	33
Profile 4	55
<b>Making Waterproof Kamiks</b>	57
Profile 5	71
<b>Making a Spruce Bark Canoe</b>	72
Profile 6	86
<b>Simple Ways to Prepare and Eat Country Food</b>	87
Profile 7	94
<b>Troubleshooting Snowmobiles and Other Tips</b>	95
Profile 8	100
<b>Trap Sets</b>	101
Profile 9	112
<b>Notes on Humane Trapping</b>	113
Further Reading	121



---

---

this volume is  
dedicated to the memory of

AL BOURQUE

colleague and friend  
drowned on Slave River  
near Ft. Smith  
June 1985

*Patrolman — Hay River 1967-69*  
*Wildlife Officer — Ft. Resolution 1969-71,*  
*Frobisher Bay 1971-75, Ft. Simpson 1975-78*  
*Regional Superintendent (Renewable Resources) —*  
*Frobisher Bay 1978-80*  
*Assistant Regional Director — Ft. Smith 1982-85*

---

---

# Acknowledgements

Thanks are due to the following organizations for assistance rendered to researchers: Hudson's Bay Company, Hudson's Bay Company Archives (Provincial Archives of Manitoba), and Ft. Providence Slavey Research Project; Association for the Prevention of Cruelty to Furbearing Animals, Canadian Association for Humane Trapping, Canadian Federation of Humane Societies, Fur Institute of Canada, and Society for the Prevention of Cruelty to Animals. Boreal Ecology Services Ltd. in Yellowknife coordinated the researching and writing of the essay on the fur trade.

Chuck Arnold, Dave Brackett, Rus Hall, Bob Janes, Bill Stewart and Rupert Tintling graciously reviewed portions of this volume and made helpful comments.

Elisabeth Hadlari helped track down historical photos, and David Milligan obligingly printed many photos on short notice. Shirley Ambrose rendered cheerful, efficient and reliable word processing of the typescript.

Special thanks are also due Johnny Klondike, Johnny Neyelle and Seepola Nowdluk for being so patient and cooperative in sharing their skills with us. The contributions of Renewable Resource Officers should also be mentioned. The tips they passed on have been hard won by experience. The officers (and the places they have served in) are:

Colin Adjun (Coppermine)  
Joe Ashevak (Spence Bay)  
Walter Bayha (Ft. Franklin)  
Bernie Bergman (Resolute, Pond Inlet, Ft. Smith)  
Tom Chowns (Resolute, Frobisher Bay, Hay River)  
Cliff Cook (Ft. Resolution, Ft. Simpson, Aklavik)  
Fred Elias (Arctic Bay, Coppermine)  
Winston Fillatre (Pangnirtung, Inuvik)  
Bob Hunter (Ft. McPherson, Frobisher Bay, Ft. Smith)  
Lloyd Jones (Ft. McPherson, Cambridge Bay, Spence Bay)  
Pauloosie Kilabuk (Frobisher Bay)  
Ben Kovik (Frobisher Bay, Lake Harbour, Eskimo Point)  
Mike Labine (Cape Dorset)  
Rick Letkeman (Ft. Good Hope, Frobisher Bay, Sanikiluaq,  
Arctic Bay, Ft. Rae)  
Rene Mercredi (Ft. Rae, Ft. Smith)  
John Stevenson (Resolute, Igloolik, Coppermine)  
Joe Tigullaraq (Clyde River)  
Paul Voudrach (Tuktoyaktuk)



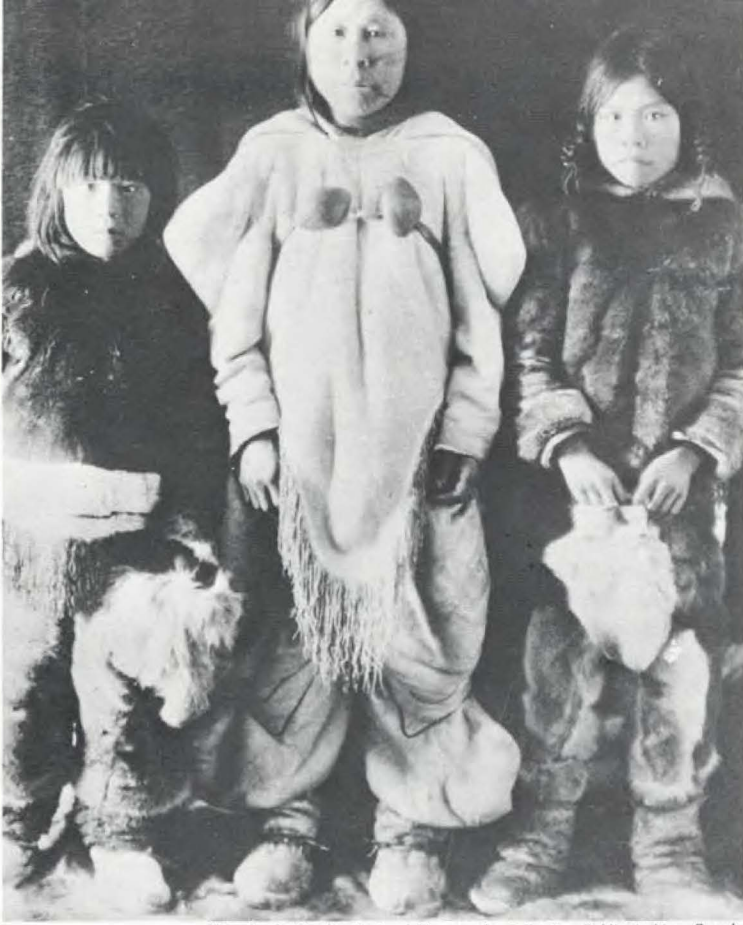

Photo by G. Moodie. National Photography Collection, Public Archives Canada.



Photo by C.W. Mathers. Ernest Brown Collection, Provincial Archives of Alberta.



Native Press.



Tessa Macintosh, NWT Dept. of Culture and Communications.

# *Fur Trade in the Northwest Territories*

---

*From the Earliest Days to the Present Time*

*by Marianne Bromley*

---

Great Slave Lake and the Mackenzie Valley . . .	8
The Mackenzie Delta and Arctic Coast . . . . .	18
Baffin and Keewatin . . . . .	22
The End of the Fur Trade's Dominance . . . . .	25
Trapping Today . . . . .	26

The fur trade has profoundly influenced the settlement and development of the Northwest Territories and the lifestyle and culture of its people. It was the abundance of furbearing mammals, and the quality of their pelts, which originally attracted Europeans to explore and eventually settle the North.

Two related but separate fur trades developed in the Northwest Territories. The earliest relied on the furbearers of the subarctic forest: beaver, muskrat, mink, marten and lynx. It was centered in the west and dealt with the Indians of the Mackenzie Basin, and later the Mackenzie Delta. The subarctic trade began in the 17th century and reached its full geographic extent 200 years later. The second trade did not develop until the 20th century and its expansion was completed in 15 years. It was based on white fox and involved the Inuit of the Arctic Coast and the Eastern Arctic. The two trades, though interrelated, have unique origins, histories, and significance.

Note: Whenever the Northwest Territories is mentioned prior to 1905, only those areas within the present political boundaries are meant.



## Great Slave Lake and the Mackenzie Valley



*Ernest Brown Collection, Provincial Archives of Alberta.*

### **Early Exploration and Development**

The northern fur trade era began in 1670 when the British Crown granted a royal charter to the "Governor and Company of Adventurers of England trading into Hudson's Bay," better known as the Hudson's Bay Company. The company was given outright ownership of all land draining into Hudson Bay (called "Rupert's Land"), but for 100 years limited its establishment of trading posts to the shores of Hudson and James Bays. Local Chipewyan and Cree Indians were encouraged to bring their furs to the posts and act as middlemen for more distant tribes. The posts were supplied by ships which sailed into Hudson Bay by way of Hudson Strait. The profitability of the

trade is indicated by the returns of 1676, when ships delivered £650 worth of goods and returned to England with £19,000 worth of furs.

The Hudson's Bay Company soon came into conflict with the French, who had been actively plying the fur trade for most of the century from their base in the St. Lawrence Valley. When France yielded its claim to Canada in 1763, Scottish merchants took control of the Montreal fur trade. Employing the same French voyageurs, they continued to penetrate Rupert's Land, and an intense rivalry developed between them and the Hudson's Bay Company to find and exploit new sources of fur.



Between 1770 and 1772 the Hudson's Bay Company sent Samuel Hearne exploring from Fort Prince of Wales (Churchill). He was the first European to travel overland to the arctic coast. He reached the Coppermine River and in his travels provided the first record of Great Slave Lake.

In 1778 Peter Pond, who was in the employ of the Montreal merchants, set up the first trading post beyond the boundaries of Rupert's Land — near Lake Athabasca, which is in the drainage system of the Mackenzie River. In 1784 the North West Company was formed by a number of Montreal merchants with Peter Pond as a partner. Under his direction the first trading post within the present area of the NWT was established in 1786. It was called Ft. Resolution and was located near the mouth of the Slave River on Great Slave Lake. In 1787 Alexander Mackenzie replaced Peter Pond, and two years later set out to explore the great river flowing out of Great Slave Lake, convinced it would lead him to the Pacific Ocean. Though his expedition was a personal disappointment, it succeeded in opening a vast new area rich in furs and provided for a rapid expansion of the North West Company's trade along the river which now bears his name.

While Mackenzie travelled north, a colleague set up trade at Lac La Martre. The Dogribs and other Athapaskan tribes no longer had to send their furs through Chipewyan middlemen or travel long distances to Hudson's Bay Company posts in the south. The North West Company had successfully established direct trade with the northern Indians around Great Slave Lake and stopped this important fur supply at its source.

Indian middlemen, particularly the Cree and Chipewyan tribes, played an important role in this early period of the fur trade. They provided a link with remote tribes which the traders could not contact directly before the establishment of posts in the Athabasca and Mackenzie regions. The middlemen took advantage of their strategic positions by charging exorbitant prices to the other tribes, apparently marking up trade goods such as guns, knives and axes by several hundred to as much as a thousand percent. They were also the first to obtain guns from the traders. With the help of European guns, the Cree and Chipewyan were able to maintain their advantageous situation and expand their territories by pushing tribes such as the Slaves and Dogribs farther north and west in the late 1700's. Fighting among tribes ceased as trading posts, especially those of the North West Company, were built in more remote areas and middlemen were no longer necessary.

*"Muzzleloaders had about a 30-inch barrel. They used to pile beaver skins flat on the ground. When they came level with the top of the barrel, then you could buy the gun."*

Joe Blondin, We Remember

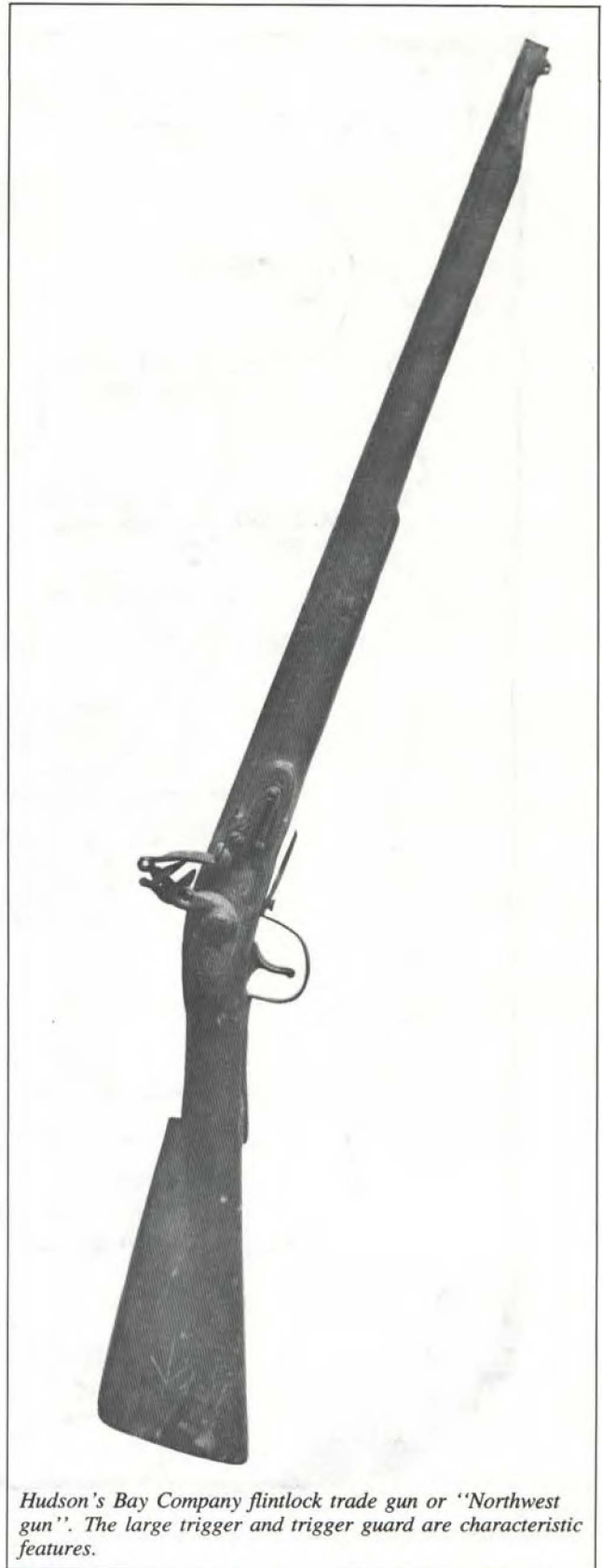

*Hudson's Bay Company flintlock trade gun or "Northwest gun". The large trigger and trigger guard are characteristic features.*

*Geology Collection, University of Alberta Archives.*



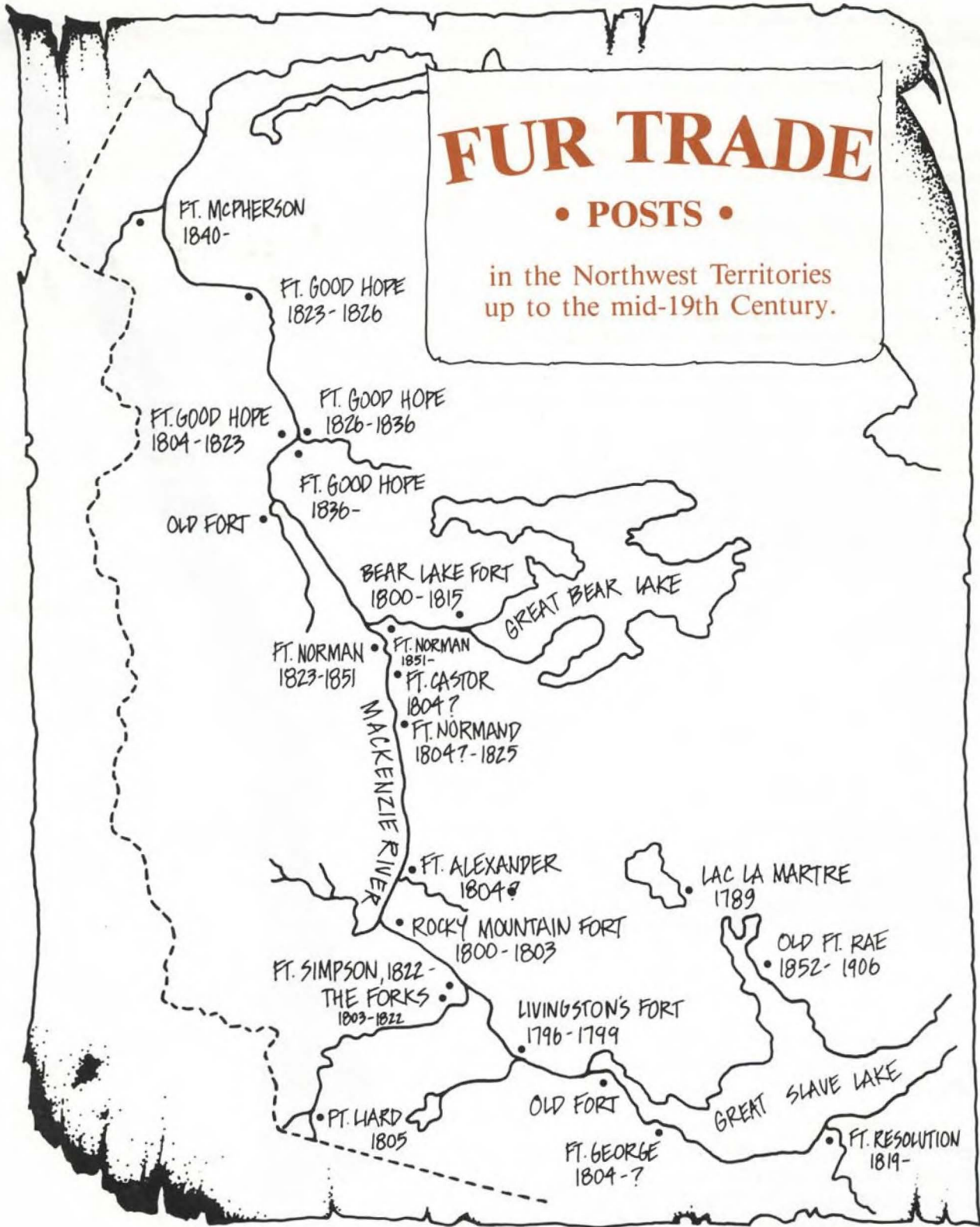





National Museums of Canada.

### North West Company Dominance

For 30 years after Mackenzie's voyage the North West Company controlled the Athabasca District, building numerous posts along the Mackenzie River and each summer moving the furs to Montreal by a lengthy canoe route. The first post on the river was established in 1796 when Duncan Livingston built a fort near the mouth of Trout River. The post lasted only three years, as Livingston was killed in 1799 near the Arctic Coast by Inuit with whom he was attempting to trade. The following year Livingston's replacement built two new posts: Rocky Mountain Fort at Camsell Bend on the Mackenzie River, and Bear Lake Fort at the outlet of Great Bear Lake.

In 1799 dissatisfaction among partners of the North West Company led to the formation of a rival group, usually referred to as the XY Company because of the mark used on its bales of furs. Alexander Mackenzie sided with this new faction. There was intense competition between the two groups and, not for the first time in the Canadian fur trade, blood was spilled. In the winter of 1804 the master of the North West Company post at Great Bear Lake was shot by an XY Company employee during a quarrel. That same year, however, the North West Company was reorganized, subsuming the XY Company and ousting Alexander Mackenzie from further involvement in the fur trade.

During this period of intense rivalry early in the 19th century, a number of new posts were built on the Mackenzie River: Ft. George, Ft. Alexander, Ft. Castor, and others, none of which lasted very long. By 1805, however, four important posts had been built: the Forks

*"The first white men were seen down from Ft. Simpson near where my cabin is now at Sucker Creek. They came down in a scow. When the People saw them they all headed into the bush and only one old fellow was brave enough to stay at the camp when they landed.*

*"They had an interpreter with them and he hollered for them to come back. One by one they did. The man who hadn't run away was given a gun as a mark of respect. Then they made it known that they wanted to barter for fur and showed the People how to make dead-falls to catch marten and mink. There was no such things as steel traps then. Although they got nothing in return they gave the People a couple of pails, copper pots, a couple of horns of black powder and about 50 rounds of bullets for the muzzleloader.*

*"The People saved the fur that winter but they didn't know how many skins they had. They just used to count on their fingers and didn't know how to count to more than ten. So they put the fur in lots of ten, took a stick that was flat on one side and put X's all along it. Every X counted as a ten.*

*"When the manager came through with his goods the next year he was presented with the stick so he knew how many skins there were. That was the start of bartering."*

*Joe Blondin, We Remember*





Ernest Brown Collection, Provincial Archives of Alberta.

*A fortune in furs.*

(later Ft. Simpson), Ft. Good Hope, Ft. Norman and Ft. Liard.

### **The Hudson's Bay Company Takes Over**

Although the North West Company remained dominant in the Athabasca District, the Hudson's Bay Company continued to move inland and strengthen its hold in other areas. Its Hudson Bay supply route was shorter and more efficient than the long series of rivers, lakes and portages which connected the Mackenzie River and Montreal. The North West Company was finally forced to yield to the size and efficiency of the British company's trading network. In 1821 the two companies were joined and the Hudson's Bay Company enjoyed monopoly control of the trade in the North.

The company immediately set about reorganizing trade in the Mackenzie Valley. Locations of existing forts were adjusted by trial-and-error to accommodate trade, often at the request of the natives. The Forks, renamed Ft. Simpson after the new governor of the company, was relocated several times over the next 30 years, as were Ft. Norman and Ft. Good Hope.

Ft. Simpson served as the administrative centre for the Mackenzie River District, as well as the location of boat

building and blacksmithing. In 1827, the shipment of trade goods received at Ft. Simpson from the main depot of York factory included: 15 crimson and scarlet belts, 50 common-coloured belts, several kilos of beads, over 150 blankets, a dozen shaving boxes, two dozen horn combs, 60 powder horns, clothes of various sorts, eight bags of flour, two kegs of butter, six cases of guns, nine bags of shot and 16 kegs of gunpowder. The fur returns sent from the Mackenzie River District for the same year totalled close to £13,000 and included over 4,800 beaver, 6,900 marten and 33,700 muskrat.

The new governor also sent expeditions along the Upper Liard River; Ft. Liard and Ft. Halkett were built to make closer contact with the Kaska Indians and eliminate the middleman system supplying Russian traders on the Pacific Coast. Ft. Halkett was short-lived, but Ft. Liard became important as a provisioning post, supplying Ft. Simpson and other forts with meat.

Provisioning posts were vital to the survival of the District. Imported food was a luxury as transportation was very expensive and goods shipped from England did not reach the remote posts along the Mackenzie River until two or three years later. Therefore, the northern posts had to rely on country food, which could be obtained



locally. A system was set up whereby Indians could trade provisions such as fish, waterfowl, hare and big game for trade goods. At least four ducks or four moose tongues or ten hares were required to equal the value of one beaver skin (one "made-beaver").

Hudson's Bay Company men, especially at Ft. Simpson, were also kept busy providing food. They grew crops such as barley, potatoes and turnips, hunted hares, and were sent to fisheries in the late summer. Posts in the District shared their resources. Ft. Simpson often supplied agricultural produce to other forts, but received much of its meat from elsewhere. In one year, Ft. Simpson was sent 2,800 kg of common pemmican, 100 kg of fine pemmican, 11,700 kg of dried meat and 500 kg of grease from other posts along the river. Despite such efforts at provisioning, food was often scarce and the men close to starving, especially during the early years. In 1833, the Chief Trader at Ft. Simpson reported in late May that daily rations for some time had been less than one kilogram of pounded meat and half-a-litre of barley meal per man.

Hudson's Bay Company posts on Great Bear Lake contributed to the success of several exploratory expeditions as they served as supply centres and winter quarters for the explorers. Ft. Franklin was built on the southwest arm of the lake (near the site of the original Bear Lake Post) in 1825 to supply Capt. John Franklin, who chose the site because of its fishing potential. Between 1825 and 1827, Franklin, George Back, and John Richardson spent the summers exploring and surveying the area around Great Bear Lake and the Arctic Coast; they spent the two winters at Ft. Franklin. During this time, the five arms of Great Bear Lake — Dease, McVicar, McTavish, Keith

and Smith — were named after Chief Traders and Factors of the Hudson's Bay Company who had helped Franklin's expedition.

In 1837, Ft. Confidence was built on the northeast arm of Great Bear Lake as winter quarters for Dease and Simpson, who explored the central Arctic Coast between 1836 and 1839. The fort was used again in 1848-49 by Richardson, Rae, and Bell during their search for survivors from Franklin's third expedition to the Arctic, which had departed in 1845.

#### A Way of Life

By the 1850's, the Hudson's Bay Company had mapped out and was quite familiar with the Mackenzie Basin. There were eight posts on the Mackenzie River, supplied annually by York boats which by that time had replaced canoes. The only white residents in the region were those associated with the fur trade. A pattern of posts had developed that basically remains the same as the pattern of communities today. The Indians were becoming increasingly dependent on the trader and attached to his post. They were still mostly nomadic, but generally travelled to the post during fall and spring, and more often as the fur trade and post began to play an ever larger part in their lives.

Trading was operated on a credit system whereby the trader "advanced debt" to the trapper for his winter trapping outfit. The trapper would then return to the post after a period in the bush and sell his furs to the same trader to make up his debt. Excess furs could be traded for goods. The amount of credit advanced was based on a trapper's skill and previous success. A large debt was therefore considered quite prestigious among the Indians.



National Museums of Canada.

*Beaver was the staple of the fur trade until the 19th century, when silk hats came into fashion in Europe.*





National Photography Collection, Public Archives Canada.

*Native students at mission school, Fort Providence.*

Until 1900, the currency used for trade was the “made-beaver” (MB), or the value of one prime beaver skin. Furs, provisions, and trade goods were all assigned prices in MB. Three marten, 10-15 muskrat, one full-size prime lynx, or six swans were considered equal to one beaver skin. Foxes other than cross fox sold for two MB. Small “common” skins received half-price. At Ft. Liard in 1855, a plain two-and-a-half point blanket cost eight MB; a common cotton handkerchief or a knife cost two MB. Four MB would buy a swan’s down vest, a scarlet belt, or just over one kilo of ball. To simplify these exchanges, the Hudson’s Bay Company had coins minted for use in their trading posts, in denominations of MB.

Typical trade items were woollen blankets, stroud, knives, axes, needles, kettles, firearms, powder, ball, shot, flint, traps, tea, tobacco, flour, beads and rum. Indians occasionally received goods in payment for doing odd jobs around the post, caring for the dogs, fishing, or assisting on river trips. Often guns and scarlet coats were made specially for chiefs, and given to them as presents along with shirts, hats, tobacco and rum.

In the late 1850’s, a new group of Europeans arrived in the Mackenzie Valley with a purpose quite different from, but initially dependent on, that of the fur traders. The Anglican and Roman Catholic missionaries came to introduce Christianity to the Indians. They relied on the Hudson’s Bay Company transportation system for travel and supplies, and on the trading posts to attract the natives to their missions, which they built close by. The

missions increased the Indians’ need to travel to the forts and reinforced the fort’s importance in the Indians’ lives, which were gradually and irreversibly changed by the combination of the fur trade and Christianity.

The roles of the trader became more numerous as he provided medical care, law enforcement, counselling, mail service and transportation, as well as trade goods. In the late 1850’s, hares — a staple food for the region — reached very low numbers in the Mackenzie River District. Europeans and Indians alike faced starvation and hardship, and traders frequently gave out food to starving Indians who came to the forts for help.

During the same period, epidemics of smallpox and measles spread along the Mackenzie River and killed many natives, who had no resistance to European diseases. Ties to the trading posts were again strengthened as missionaries built schools in Ft. Norman and Ft. Providence, and a hospital in Ft. Providence, to care for orphans left after the epidemics.

*“Hudson’s Bay brought in pans and copper kettles but before that we had nothing to boil meat in so it was just roast, roast, roast! In summertime we used to put a skin or a moose’s stomach into a hole and put water in it, then hot hot rocks. We kept them clean and were careful not to burn the skin. That was how we boiled meat.”*

*Andrew Kunnizzi, We Remember*



In 1870 the Hudson's Bay Company sold Rupert's Land to the recently established government of Canada for £300,000. The Company, however, continued to dominate the fur trade, and the fur trade continued to dominate the North, as the new government put its efforts into building a transcontinental railway. There were at that time only nine trading posts within the present boundaries of the NWT: Ft. Good Hope, Ft. Liard, Ft. McPherson, Ft. Norman, Ft. Providence, Ft. Resolution, Ft. Simpson, Hay River and Old Ft. Rae.

In 1875, fur returns for the Mackenzie River District totalled \$115,224. Ft. Simpson and Ft. Liard were the leading posts, accounting for \$13,500 to \$16,000 each. Returns fell continually over the next five years, but by 1885 had reached a District total of \$104,554, with one or two very good years in between. In 1880, fur returns from Ft. Liard included 91 lynx, 1400 marten, 1690 beaver, 120 bear, and 35 wolverine. Between 1875 and 1885, values for prime pelts went from \$7.90 to \$11.48 for bear, from \$2.56 to \$4.09 for beaver, from \$1.82 to \$1.30 for red fox and from 16¢ to 7¢ for muskrat. During this period, silver fox was the most valuable pelt, worth \$53.53 in 1885.



Louis Romanet Collection, University of Alberta Archives.

*A fur baler in Fort Norman.*



National Photography Collection, Public Archives Canada.

*Furs baled for shipment south.*





Photo by E.R. Gowen. Louis Romanet Collection, University of Alberta Archives.

### Competition in the Mackenzie Valley

Near the end of the 19th century, several developments took place which changed the nature of the fur trade. Transportation to the Athabasca-Mackenzie Region was greatly improved by the introduction of steamers to both rivers in the late 1880's, and by the construction of a railway to Edmonton in 1890. Consequently, the Hudson's Bay Company monopoly was broken as the Mackenzie Basin became more accessible to "free traders". During the 1890's, the company of Hislop and Nagle built stores at Ft. Rae and Ft. Resolution and became a major competitor. Independent traders also set up at Ft. Providence and Ft. Good Hope. Meanwhile, the Hudson's Bay Company had built only two new posts between 1870 and 1900 (Ft. Smith in 1874 and Ft. Rae in 1887) while closing down one (Hay River in 1875).

By 1894 the first white trappers had arrived north of the 60th parallel. The trickle of newcomers turned into a flood when the Klondike Gold Rush began in 1897. Hundreds of men tried to reach the gold field via the Mackenzie Valley, and many remained to trap and prospect. Poison baits appeared in the north for the first time. Traders continued to proliferate, some setting up posts at existing centres, while many others were itinerants, travelling north from Edmonton for a summer of trading. By 1902 Ft. Resolution had six stores.

As the competition picked up, the growing trapping pressure began to seriously reduce the numbers of furbearing animals. Consequently, the Northwest Game Act, originally passed in 1906, was completely revised in 1917 to better protect both furbearers and native trappers, whose livelihood was being threatened. The Act established closed seasons on furbearers. In addition, it required all trappers and traders who were not indigenous peoples and bona fide residents of the NWT to hold a licence. Beginning in 1918 and throughout the first half of

the 20th century, a series of preserves — at one point nearly covering the entire NWT — was set aside for exclusive use by native hunters and trappers. Continuing concern for native subsistence and declining numbers of furbearers led the NWT Council, in 1923, to increase licence fees for non-resident trappers from \$25 to \$75 for British subjects, and from \$50 to \$150 for others. Trading licence fees were also raised and residency requirements were changed from two to four consecutive winters.

By 1920 there were two major companies competing with the Hudson's Bay Company — Lamson and Hubbard, and Northern Traders Limited, which had bought out Hislop and Nagle. The period of greatest competition occurred throughout the 1920's and into the 1930's. The influx of independents from the south continued to grow as transportation improved and fur prices soared. The prices for both white fox and muskrat were 20 times higher than at the turn of the century. In 1920 the Hudson's Bay Company at Ft. Simpson paid \$1,000 for 154 muskrats. In 1929, the least-valued fox (red) brought \$37.42, while white fox went for \$54.15 and silver fox for \$104.65. Income reached into thousands and tens of thousands of dollars, compared to the national mean annual wage in manufacturing industries of under \$1,000. The number of white trappers increased from 140 in 1920-21 to 500 in 1926-27. Forty-one trading licences were issued in Ft. Rae alone in 1926. More posts were built at more locations, dispersing the trade throughout the region, away from the major centres. During the 1930's, 45 posts were opened at 13 new sites along the Mackenzie River, although most of these outposts were short-lived. Overharvesting continued, and the mink catch dropped from 21,205 in 1923-24 to 3,630 in 1927-28. The muskrat harvest also fell after reaching a peak during the same period.



A new era of transportation on the Mackenzie River.

Louis Romanet Collection, University of Alberta Archives.





Ernest Brown Collection, Provincial Archives of Alberta.

*Hudson's Bay Company, Fort Resolution, 1901.*

### The Decline of the Fur Trade

By 1930, the Indians of the Mackenzie Valley had been exposed to the fur trade for over 130 years. Trapping had become a traditional activity, along with hunting and fishing, in the annual subsistence cycle. The trading posts were becoming settlements, as more Indians built permanent houses which they began to occupy for greater parts of the year.

Towards the end of the 1930's, the Depression was affecting the Mackenzie Valley as fur prices crashed. In 1938, trapping licences were restricted to indigenous peoples living in the NWT and white residents already holding a licence. Many posts closed and trade was once again centralized at the major forts, conducted mainly by natives who also trapped. All major companies failed except the Hudson's Bay Company, which regained its monopoly. Most independents left or turned to mining, which was overtaking the fur trade as the region's chief industry. Low fur prices and high equipment costs following World War II signaled the end of the traditional fur trade era in the Mackenzie Valley.



Glenbow Institute.

*Hudson's Bay Company store in Fort Smith, early in the 20th century.*



## The Mackenzie Delta and Arctic Coast

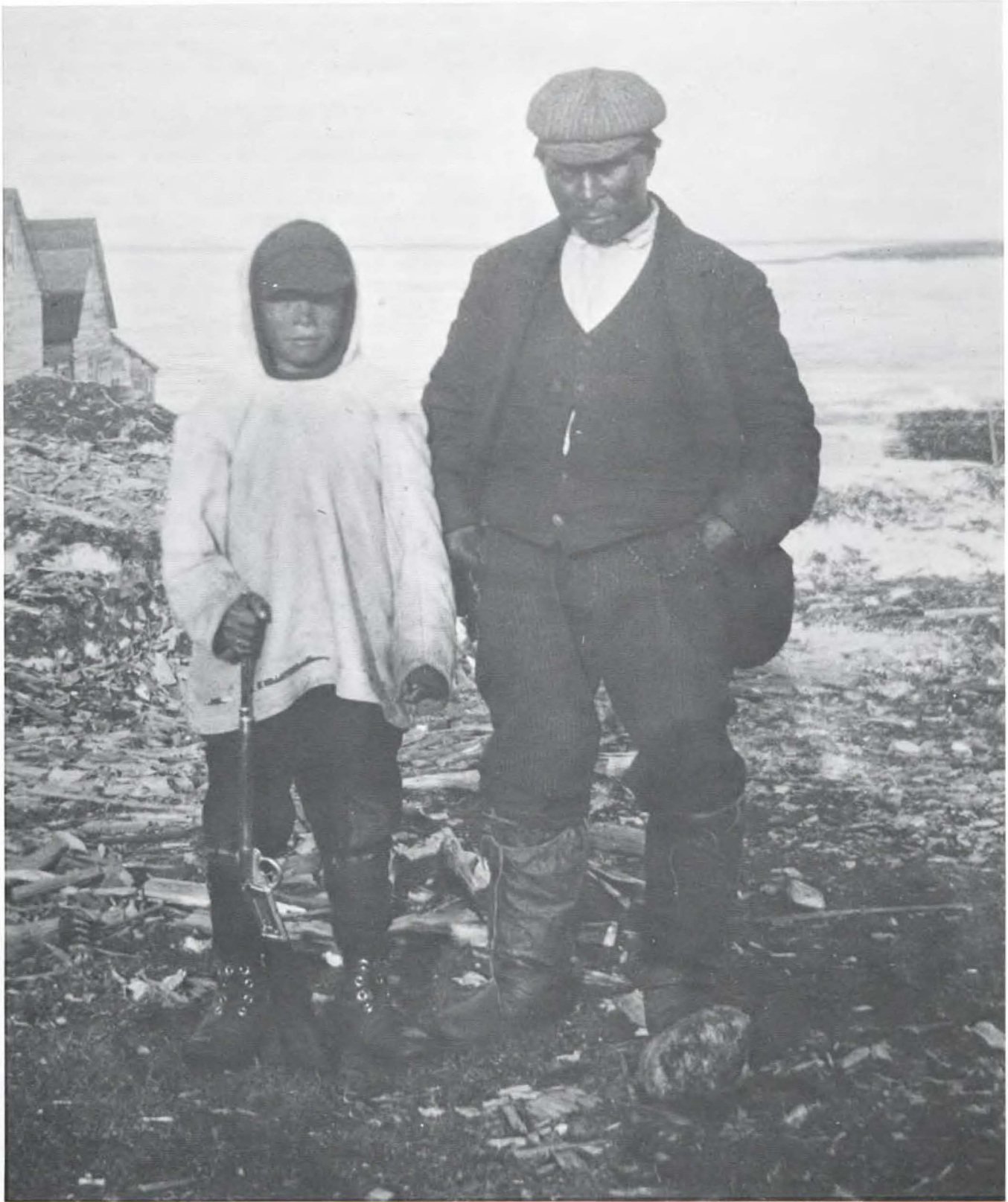

*Louis Romanet Collection, University of Alberta Archives.*



### Early Development

Trading in the Mackenzie Delta started much later than in the valley. Trade goods were introduced to the natives from two directions. The earliest access was by fur traders from the south. The Hudson's Bay Company built Peel's River Post (Ft. McPherson) in 1840 at the end point of its Mackenzie River trade route. The post received no direct trade until after 1850 when Indians and Inuit started bringing furs to the fort. Trade gradually picked up, and was introduced to more distant groups by middlemen and short-lived outlying posts. However, even in the late 1850's, traders at Ft. McPherson discouraged the establishment of regular trade with the Inuit because of the "deadly enmity" between them and the Indians who also traded at the fort. Bernard Ross, Chief Trader at Ft. Simpson, recommended that a post be opened along the Anderson River exclusively for the Eskimo of that area. They were friendly to the traders and anxious to have a fort nearby. He cautioned that the outfit should start with only "tobacco, knives, ironwork and traps," and that guns and ammunition should not be sold for several years. Ft. Anderson was established in 1861, but was abandoned in 1866 because the location was not convenient enough to draw large fur returns.

The closing of Ft. Anderson may have encouraged greater numbers of Inuit to visit Ft. McPherson for the trade they desired. By the 1880's, several Kutchin Indian tribal groups and the Mackenzie Eskimo did regular trade at the fort. Fur returns for 1880 totalled \$10,200 and included 297 beaver, 578 white fox, 1813 marten and 2700 muskrat.

As they had in the Mackenzie Valley, the missionaries arrived in the wake of the traders, reaching the Delta after 1860. The natives began to visit the forts for religious services as well as trade. The trader complained that provisions were scarce at Ft. McPherson during the winter of 1861 because the missionary had brought all the Indians to the post in the fall, when they should have been out hunting. He stressed that, in order to prevent similar situations in the future, the missionary should visit the Indian camps or wait until the Indians came to the post with provisions.

### The Whaling Era

Just before 1890, a major development occurred in the Western Arctic which would profoundly influence trade for the next 25 years, and forever change the lives of the natives. American whalers arrived at Herschel Island.

In 1888, Charles Brower, manager of the Pacific Steam Whaling Company station at Point Barrow (Alaska), sent one of his harpooners and several Eskimos on a voyage along the Beaufort coast to the Mackenzie Delta. There were rumours that this part of the ocean was full of whales. The men spent the winter exploring and returned, after a journey of 1600 km in an open whaleboat, with confirmation of a plentiful resource and a good harbour at Herschel Island. The steamers proceeded to the new loca-

*"John Firth was the Hudson's Bay Manager in Fort McPherson. You could buy dry goods in the store: tea, sugar, flour. Mr. Firth had to ration it so it didn't run short. He used a cup and measured the loose tea by the cupful on to the cloth. Five cups of tea . . . that's for all winter."*

Sarah Simon, We Remember

tion. The "Mary D. Hume" and the "Grampus" were the first to winter there in 1890-91. By so doing, they hoped to take full advantage of the ice-free season for hunting.

Trade was initiated with the natives for meat needed by the wintering crews. The first winter, 60 Eskimos camped near the ships and provided the whalers with fresh caribou, ptarmigan and goose. The Pacific Steam Whaling Company made an unprecedented harvest, and more ships followed to spend the winters in the Arctic — mainly at Herschel and Baillie Islands — and take part in the fortune come spring. The winters were long for the men on the ships. But, although they were starved for word from outside, the whalers refused the deal offered by the Hudson's Bay Company: mail privileges in exchange for ending trade with the natives.

The whalers were serious competition for the fur traders. Goods could be transported much more cheaply by ship from San Francisco than by the Hudson's Bay Company's river route. The lower prices and better quality and variety of trade items offered by the Americans drew Eskimos and Indians away from Ft. McPherson. By 1894-95, there were 15 ships and 600 extra men wintering on the island. It is estimated that over 4,500 kg of caribou were consumed per year at each ship. The men also ate mountain sheep, moose, ptarmigan and fish. As well as trading for meat, the whalers bought furs, clothing, and baleen from native-killed whales. During the 1890's, most ships could apparently obtain 300 kg of baleen in trade each season.

*"The first white man I ever saw was Mr. Steffanson and his partner, Billy Banksland. That's the first time we saw a match being used by white people, and we were really happy when Steffanson gave us a snow knife . . . I remember the only knives we used to have were the antlers of the caribou . . . The following year I started hunting and that's the first time in my life I ever got caribou with a bow and arrow. I must have got about nine or ten or eleven at that time. Then in later years more white people started coming in and that's the time I saw my first rifle — musket rifles."*

Guy Hologak (Berger Inquiry, Proceedings at Community Hearings, Vol. 41)



The whalers had a much greater impact on the natives of the Mackenzie Delta and Arctic Coast than had the fur traders up to that time (1900). They came in great numbers and they interacted with entire native families on a year-round basis. A few Americans lived and hunted with the Eskimos at their winter camps. Others brought native families to Herschel to work as boatmen, seamstresses, dogdrivers, and contract hunters. Inuit and Indians were exposed to many aspects of American life. Crews played baseball on the ice. In 1893, the "league" had four teams — the Herschels, Northern Lights, Arctics, and Pick-ups. In 1894-95, whalers brought their wives and children to the island and the social atmosphere flourished. Fancy dress parties and dances helped pass the winter. But the cultural interaction also had serious negative consequences. Liquor abuse and crime were common problems. And diseases proved critical as they killed the majority of the original Mackenzie Eskimo population during the whaling years. These people were replaced by Eskimos from the interior of Alaska, who had been steadily immigrating since the arrival of the whalers

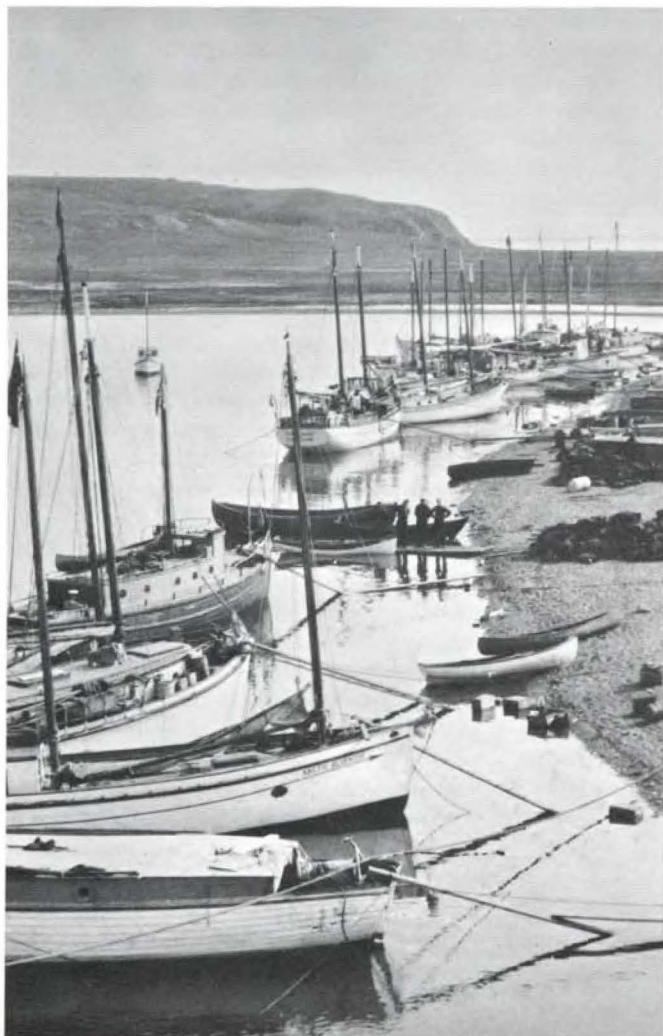

National Photography Collection, Public Archives Canada.

*Early in the 20th century, times were prosperous on the arctic coast, and schooners proliferated.*

and whose caribou hunting skills were much in demand. Another reason for their influx was the growing scarcity of caribou in Alaska, caused by the demand for meat by whalers. It was not long before the numbers of both big game and whales suffered from the heavy harvest pressure in the Canadian Arctic.

### **The Collapse of Whaling**

As baleen catches dropped after 1900, the whalers changed their strategy. Increasingly, whaling became incidental to fur trading instead of the other way around. Small schooners with limited crews and low operating costs replace the larger ships. The whalers spent the winters in the Arctic trapping and trading, and attempted to kill a few whales before returning south.

In 1907, competition from a new invention — spring steel — caused the price of baleen to plummet. The whaling industry collapsed completely, bringing the end to an era in the Western Arctic. Even trading slowed down for several years as most of the whalers abandoned the Arctic. In 1909 only three ships went north and in 1910 only a dozen white men were making an independent — and difficult — living on the Arctic Coast.

The transition was hard on many of the Inuit. Twenty years of interaction with white men had changed their lifestyle and destroyed their independence. Big game populations were depleted. Traditional skills had been lost, and tools which could be made from locally available resources were replaced by manufactured goods. Natives still obtained most of their food from the land, but they had become heavily dependent on trading for the technology which they now found necessary to harvest their food. Many people had learned to depend on the ships and their cargoes, which no longer arrived. The region was primed for an expansion of the fur trade.

### **The Fur Trade Takes Hold**

The Hudson's Bay Company's opening of posts at Aklavik and Kittigazuit in 1912, the first downstream extension of the Mackenzie River posts in over 70 years, spurred the development of a major fur trade along the Arctic Coast. In 1915, gas schooners made their way north, replacing the less efficient steamers of the whaling years. "Floating posts," boats often owned by former whalers, were common travelling the coast as far east as Coronation Gulf and conducting winter trade from sheltered harbours. This tactic was outlawed in the late 1920's, apparently through pressure from more established interests.

Permanent posts also spread rapidly as independent traders, including several whaling captains, competed with the Hudson's Bay Company. Captain J. Bernard operated a store at Bernard Harbour during 1911-14. Captain C. Klengenberĝ built a small post at the present site of Coppermine in 1916. Klengenberĝ had been the first white man in many years to trade with the Copper Eskimos when, in 1905-06, fog forced him to winter on the coast of Victoria Island. The Hudson's Bay Company opened



stores on Herschel Island in 1915, and Baillie Island and Bernard Harbour in 1916. In less than 10 years, numerous posts dotted the Arctic Coast between Herschel Island (1915) and King William Island (1923).

At the same time, however, concern was being expressed by government officials over the influx of white trappers and traders throughout the NWT. There was fear that wildlife resources might be seriously depleted, causing hardship for the natives. As a result the first of a series of preserves was created in 1918. It restricted hunting, trapping, and trading on Victoria Island to natives. The same conditions held when the Banks Island Preserve (1920) was created, then the Arctic Islands Preserve (1926). The latter included all arctic islands except Banks and Victoria, as well as the northern tip of Baffin Island and the northern mainland from Melville Peninsula to Bathurst Inlet.

### The Fur Trade Boom

The fur trade boom of the 1920's was not restricted to the Mackenzie Valley. Trading reached its height in the Western Arctic during the same period. Many white trappers and traders continued north along the Mackenzie River to reap the benefits of high fur prices and good harvests in the Delta. Muskrats were caught by the hundreds of thousands. Trappers enjoyed great prosperity, often earning higher incomes than the average Canadian. Money was freely spent on luxuries and leisure activities, but many Inuit also invested in capital items such as boats. In 1924, the Eskimo fleet at Aklavik included 39 schooners and 28 whale boats, valued at \$128,000.

Trading was very competitive. With their schooners, Eskimo trappers could travel along the coast in search of the best trade deals. The Northern Whaling and Trading Company of Captain Pedersen, the last of the whaling captains in the north, was a major competitor, as well as the firms of Northern Traders Limited and Canalaska Trading Company. The Hudson's Bay Company responded by opening many new posts, including those at Cambridge Bay (1923) and Gjoa Haven (1927).

In the late 20's, fur prices continued to climb, but harvests fell as the heavy trapping pressure took its toll, especially on animals producing "fine fur," such as mink. Poor white fox harvests on the mainland and increasing competition from white trappers prompted several Inuit to extend their trapping to Banks Island. Although two previous attempts had been made to trap there — once by American traders with Alaskan Eskimo trappers, and once by the Hudson's Bay Company — both were blocked by government policies protecting natives. In 1928, four Inuit from the Baillie district went to Banks Island on their own initiative and returned with over 100 foxes each. Captain Pedersen and Ole Anderson, a trader from Atkinson Point, encouraged more natives to try out Banks and offered to provide the necessary outfits. The next year, 12 people went over and returned with 200-500 foxes each. Such an excellent harvest confirmed the island's reputation and initiated an era of colonization by

elite, highly-skilled trappers who travelled by schooner seasonally between Banks Island and Aklavik. They spent the winter trapping on the island and returned to the mainland in summer, usually with a fortune in white fox pelts.

Aklavik, meanwhile, was achieving fame as the major fur trade centre in the north. It evolved into a settlement with several trading posts and southern institutions including a hospital and a post office. By 1925 it handled more trade than Ft. McPherson, and by the end of the decade it was the regional centre of administration and contact with the south as well. Ft. McPherson, along with Arctic Red River, remained an important trading post for Indian clients.

Around 1930, the Depression caused muskrat prices to drop by 75%. Most trappers' incomes fell below the national average wage level, and have never significantly recovered. But, although prices were low, trapping and trading in the Delta continued to pick up throughout the 1930's despite — or perhaps because of — the Depression. With unemployment high, trapping at least offered a chance to make a living. Aklavik was at its peak in the early 1930's, as Banks Islanders brought in boat-loads of white fox and the Delta provided a large muskrat harvest for the growing numbers of trappers.

### The Decline of the Fur Trade

By the middle of the 1930's, the Depression had caught up to the Western Arctic and brought a slump in the fur trade as prices continued to fall. Many posts closed in the late 1930s, especially along the coast. The Hudson's Bay Company lost most of its competition and closed many of its own outposts. Of the 35 Company stores along the coast before 1940, only nine were left at the end of that year. Captain Pedersen sold out in 1938. Trading was concentrated in the established settlements in the Delta, which gradually became centres for all types of activities. The Hudson's Bay Company moved its coastal headquarters from Baillie Island to Tuktoyaktuk in 1938, and several hundred natives moved from the coast to the town. Besides the trading post, mission, and police office, settlements by this time had a few other southern institutions and several permanent houses. Many of the natives still lived most of the year on the land. However, they visited the settlements more often and, though not yet adopting the more sedentary life, they were quickly becoming more familiar with it.



## Baffin and Keewatin



*NWT Archives.*

### The Whaling Era

Ever since it received its royal charter in 1670, the Hudson's Bay Company had been supplying itself by sea. Its ships voyaged annually through Hudson Strait into Hudson Bay, where trade goods were off-loaded and the precious cargo of furs taken aboard. Since the 18th century Hudson's Bay Company traders had ventured north in sloops during the summer to trade with the Keewatin Inuit. Nevertheless, the commercial fur trade did not become active in the Eastern Arctic until the beginning of the 20th century. As in the Western Arctic, this occurred as a direct result of the whaling industry.

Whaling had commenced on a regular basis in Davis Strait in 1719, but was restricted to the Greenland side until 1817. In that year the first whaling ships made their way westward to Baffin Island. For the remainder of the century, bowheads were hunted nearly to extinction in the Canadian Eastern Arctic. In 1851 the first whalers overwintered on Baffin Island in order to get a headstart on whaling the following year. Thereafter it became an established practice to set up shore stations for overwintering whalers, who thus became the first white men which the Inuit dealt with on a regular and prolonged basis. Inuit collected round the whaling stations and many became employees. They supplied meat and clothing, crewed whaleboats, and grew increasingly dependent on imported goods. Soon, whaling stations became just as dependent on the Inuit for provisioning as trading posts in the west were on the Indians.

In the Hudson Bay area, which was not exploited for whales until the middle of the 19th century, whalers set up shore stations at Roes Welcome Sound, Repulse Bay, Southampton Island, Marble Island, and elsewhere. On Baffin Island shore stations were built in Cumberland Sound, Frobisher Bay, Pond Inlet, and along the north shore of Hudson Strait.

Some trading in furs was conducted at whaling stations, but as whaling became less profitable, trading assumed a greater importance. Following the collapse of arctic whaling early in the 20th century, many former whalers opened trading posts at traditional whaling stations in the Baffin Island area. They were soon followed by the Hudson's Bay Company. In the Keewatin, whalers played less of a part in the transition to fur trading, leaving this role to the Hudson's Bay Company.

### The Fur Trade Takes Hold

The first fur trading post to be established in the NWT outside the Mackenzie region was built in Port Burwell around 1895 by Captain Blandford. The Hudson's Bay Company built its first Eastern Arctic post in 1909 at Wolstenholme on the south side of Hudson Strait (Quebec). Thereafter the fur trade spread rapidly throughout the Eastern Arctic as the market for white fox reached its peak. Within 15 years the Hudson's Bay Company had established a battery of trading posts (many of which remain today as settlements) throughout Inuit territory. Stores were opened at Chesterfield Inlet and

Lake Harbour in 1911; Cape Dorset in 1913; Repulse Bay in 1920; Eskimo Point, Pangnirtung, and Pond Inlet in 1921; Clyde River in 1923; Coral Harbour in 1924; and Baker Lake in 1925.

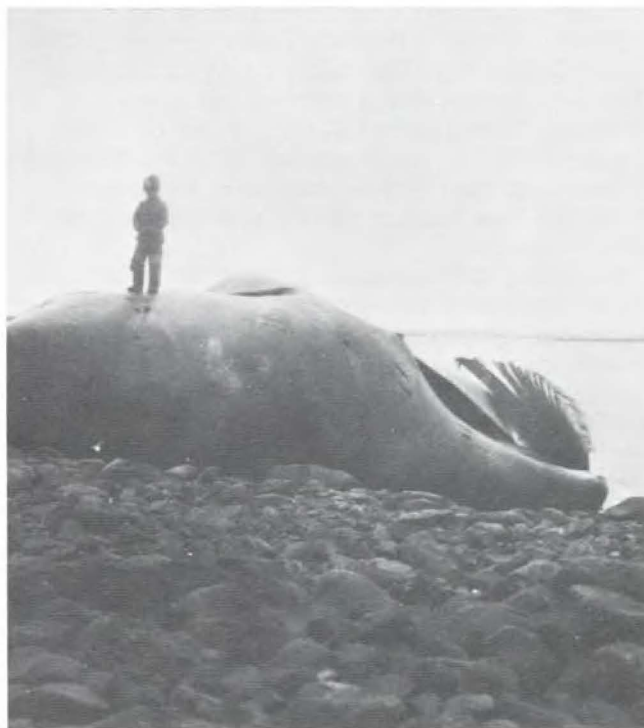

*Beached bowhead whale.*



*Bowhead whale ribs, Kekerten Island.*



Fur trading posts were operated by the Hudson's Bay Company and others at many additional locations, which failed to achieve settlement status. In the Baffin, some of these were Blacklead Island (1921-36), Cape Haven (1911-27), Cape Mercy (1911-27), Hamlen Bay (1911-27), Kekerten (1915-25), Kivitoo (1911-16), Padle (1910-27), and Ward Inlet (1922-48). In the Keewatin, there were (among others) posts at Coats Island (1918-28), Mansel Island (1925-49), Padlei (1926-60), Tavanni (1928-51), and Wager Bay (1926-47). It should be noted that many of these locations in the Eastern Arctic had been active as whaling stations prior to the dates shown.

Fur trading quickly became a central part of Inuit life. Soon many natives were completely dependent on the trader, who encouraged them to spend more and more time trapping fox. Long trips to the trading post, often outside traditional hunting areas, were made quite frequently and sometimes interfered with caribou and seal hunts. Inuit material culture changed as wool clothing, European food, and modern equipment were obtained in exchange for fox pelts. Traders made great profits at the expense of the natives in the early years. In 1923, a \$25 rifle cost 40 fox pelts, each bringing \$40 in London.

#### **The Decline of Competition**

To protect the interests of natives, the Arctic Islands Preserve was created in 1926. It included the northernmost parts of Baffin Island and the Keewatin, and restricted hunting, trapping and trading there to natives. Shortly afterward the Sabellum Trading Company closed its posts on Baffin Island, leaving the area to the Hudson's Bay Company.

In the Keewatin the initial dominance of the Hudson's Bay Company was challenged by the French firm of Revillon Frères, as well as a number of independent traders. But after the price of foxes began to fall in the 1930's, a number of posts were bought out by the Hudson's Bay Company while others simply closed shop. By the end of World War II, the Hudson's Bay Company had regained its dominance and had begun trimming down its operation by closing many of its own posts, in both the Keewatin and the Baffin.

In less than 40 years the fur trade brought major changes to Inuit life. The Inuit still lived a subsistence lifestyle based on resource harvest and seasonal travel; however, fox trapping had become the fulltime winter occupation of most adult males.

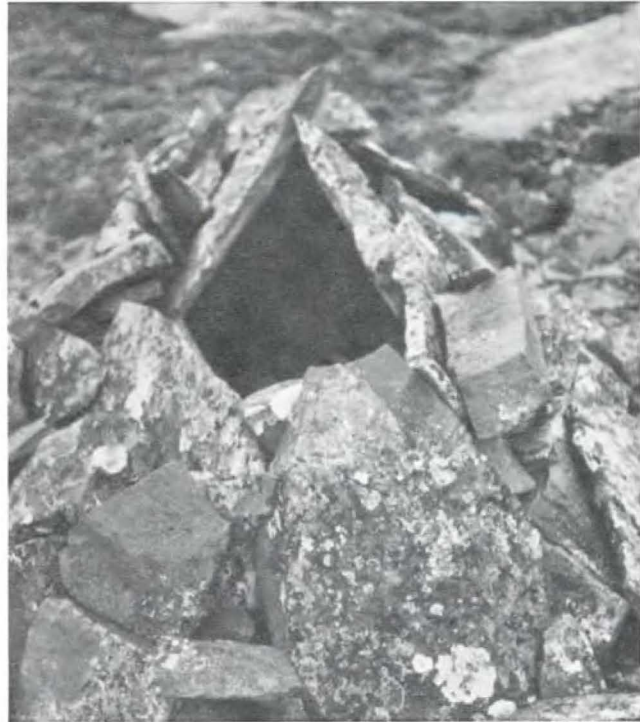

*Stone fox trap.*

C. C. Shank

## The End of the Fur Trade's Dominance

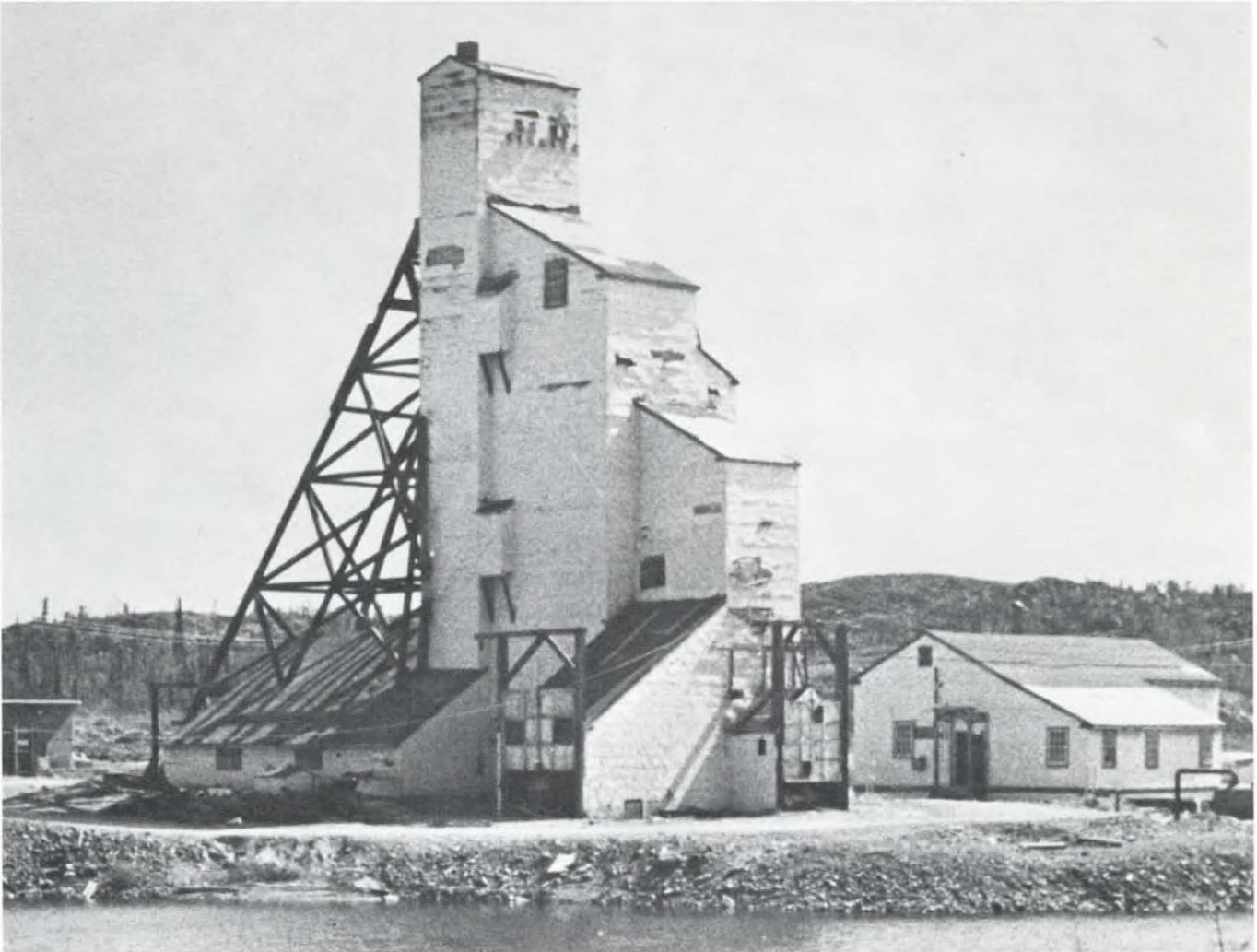

*Tessa Macintosh, NWT Dept. of Culture and Communications.*

Until 1946 furs were the most valuable resource exported from the NWT. After World War II, however, the winds of change once more swept through the northland. The fur trade entered a long decline which lasted through the 50's and 60's. The resulting hardship experienced by native people was one of the reasons for the government's decision to move them off the land and into settlements. Family allowance payments, started in 1946, were often the first cash income for natives other than from fur. Social assistance, local schools, government housing, and health care became regular aspects of settlement life.

By the late 1960's the shift to settlement life was basically complete. The Hudson's Bay Company still operated most of the stores which it had in the 40's, but furs represented a small part of the business, which had changed its emphasis to the retail trade. Opportunities for wage employment increased, especially in the areas of mining, gas and oil exploration, tourism, and government

administration. In 1981 mineral production contributed \$541 million in revenue to the NWT, the oil and gas industry \$52 million, and the fur trade \$5 million.

In the world market, the demand for furs slowed down due to changing fashions and growing pressure from welfare groups to boycott animal skins obtained by trapping. The popularity of fur as a functional item also fell as wool, down, and synthetics provided warmth with convenience, and at a fraction of fur's cost. Finally, the remaining demand for fur was often filled by synthetic imitations and ranched pelts.

Fur revenue continued to provide income to many families in the NWT, but generally represented only a small proportion — often well under 20% of a family's or community's cash income. Between 1973 and 1982, there were close to 3,800 people who trapped each year in the NWT. Each received an average of \$980 in fur returns per year. In 1981-82, only 8% earned more than \$5,000.



# Trapping Today



Tessa Macintosh, NWT Dept. of Culture and Communications.



Native Press.



Bob Wilson, NWT Dept. of Culture and Communications.



### A Persistent Lifestyle

Although settlement life reduced the need for and interest in trapping, and replaced the camp as the centre of activity, the traditional lifestyle has not been abandoned. Many natives still rely on the land as a source of income, country food, security, and identity. Land-based activities, including trapping, provide an important link with the past and a means for coping with a culture which is still new, foreign, and often confusing.

Moreover, despite all the cultural and social changes which have overtaken the NWT since World War II, there is still much disparity in economic situations across the north. In 1901 the number of non-natives resident in the NWT was 137; eighty years later it was 19,000. In 1984 the potential labour force was 52% native and 48% non-native, while the unemployment rate was 31% and 7%, respectively. Today, the majority of people are supported by wage employment in only a few settlements. Most of the remaining communities are small and remote, with hunting and trapping often the only means of support. It is no coincidence then that nearly all trappers in the NWT are once again native in origin.

Trapping in the north, however, should not be seen as an occupation in the same way that driving a truck or balancing a ledger is. It is but one part of an entire way of life. Other aspects include not only hunting and fishing, but also all the myriad skills and traditions associated with them. When a family moves out on the

land for a period of time it is to re-affirm their ties with it as well as to reap its benefits. One or two activities may predominate, depending on the time of year, but they are all part of a cycle. Most trapping is done in winter before Christmas, with hunting and fishing being opportunistic. After Christmas, hunting often becomes more important with trapping being secondary, when engaged in at all. Spring is a favourite time of year when mild weather can be enjoyed without the bane of insects. Fish runs are tapped, returning birds are exploited, and in the west beaver and muskrat are shot or trapped. Summer is a time for fishing, sealing and whaling, as well as the occasional hunt for big game. This cycle may be interrupted if temporary employment is found — perhaps as a guide, or in some capacity with a pipeline or seismic crew — but the devotion to the land remains. In fact, wage employment is often the means by which ties to the land are retained, for it enables people to purchase expensive yet necessary items, such as snowmobiles.

It is clear, therefore, that the value of trapping cannot be measured simply by the volume of fur sales. To it must be added (in terms of pure economics) the estimated value in country food which natives harvest annually in the NWT — at least \$40 million. But even more important is the cultural value of trapping as a component of life on the land. As many natives testified in the course of the Mackenzie Valley pipeline hearings conducted in the mid 70's, the land is essential to their cultural identity in



Tessa Macintosh, NWT Dept. of Culture and Communications.

*Life on the land remains an important activity for native people in the Northwest Territories.*



a way that is difficult for other Canadians to understand. In his report, Thomas Berger wrote:

There is a tendency for us to depreciate native culture. Many white northerners have argued that the native way of life is dying, that what we observe today is a pathetic and diminishing remnant of what existed in the past. The argument arises as much from our attitudes toward native people as from any process of reasoning. We find it hard to believe that anyone would wish to live as native people do in their homes and villages. We show indifference, even contempt, for the native people's defence of their way of life. We tend to idealize those aspects of native culture that we can most easily understand, or that we can appropriate to wear or to place on a shelf in our own homes. We simply do not see native culture as defensible. Many of us do not even see it as a culture at all, but only as a problem to be solved. But we must learn what values the native peoples still regard as vital today. Only then can we understand how they see their society developing in the future . . .

### Carrying On

Trapping is a particularly expensive proposition these days. A substantial capital investment is necessary to trap efficiently and successfully. The trapper must buy, and maintain, the gear used specifically for trapping and hunting — such as traps, firearms, and ammunition — and equipment used in travelling and camping — including snowmachine, toboggan or komatik, tent, stove and gas. Because trappers tend not to keep detailed records of expenses, it is difficult with any certainty to put an exact dollar value on the amount spent on gear. But \$3,000 would be a conservative estimate of the minimum cost for a very basic initial outfit — not including transportation. The snowmachine is another \$2,000 to \$3,500 plus gas, which averages \$.65/l in Yellowknife and twice as much in the more isolated settlements. Bush plane charters are sometimes necessary to take trappers and their gear to remote camps. The minimum yearly cost for maintaining an outfit is probably around \$2,000, not including the snowmachine, which is usually replaced every few years. Some trappers have estimated their inventory of traps alone to be worth \$4,000. Others have suggested a long-term investment of \$20,000, including trapline cabins.

The biggest problem the trapper faces is acquiring the capital necessary for a trapping outfit. The credit system of the fur trade era has gone the way of the "made-beaver". A few bush outfitters will extend small amounts of credit to reliable individuals; but mostly, the prospective trapper must make his own way, or rely on government help. And, since revenue from trapping is intermittent, unpredictable, and variable because of its dependence on world markets, biological cycles, and the whims of fashion, none of which trappers can control, the government does indeed help. In fact, one of the major

activities of the NWT Department of Renewable Resources is the providing of assistance to hunters and trappers. Out of the Department's 1984 budget of \$6,568,000 (excluding salaries and capital acquisitions), more than one-third (\$2,439,000) was disbursed in grants and contributions.

Some of the programs funded are listed below:

Trappers Assistance Loans — Non-interest loans to trappers for outfitting or transportation. Maximum \$1,500 per trapper. Total contributions for 1985-86: \$55,000.

Trappers Incentive Subsidy — A grant to assist trappers based on the previous year's fur sales. There are three components:

- a) sealskin subsidy — based on a certain amount per pelt (\$5 each in 1985-86).
- b) subsidy on other fur — percentage paid on fur income in excess of \$600 to a maximum of \$3,000 (excluding polar bear, muskox and seal).



Maggie Akajuk stretching a sealskin in Pangnirtung.

Bob Wilson, NWT Dept. of Culture and Communications.



c) gasoline subsidy — additional percentage paid on fur income.

The grant is paid in a lump sum annually. Total grants for 1985-86: \$475,000

Wildlife Committees — A contribution averaging \$15,000 to all active associations in the NWT representing the interests of hunters and trappers within a community. Total contributions for 1985-86: \$825,000.

Outpost Camps — Assistance to families and groups (less than 60 in number) who wish to live off the land in isolated locations and pursue traditional lifestyles. Total contributions for 1985-86: \$785,000.

It is clear from these programs, and from others offered by the Departments of Education, Economic Development, and others, that government opinion has reversed

itself from the position held in the 50's and 60's. Industrial development and wage employment are necessary components in the future of the NWT, but they are no longer considered the only ones. The over-ruling desire of northern natives is to forge a society which combines the best of modern Canadian life with their own traditional culture. Native rights have been entrenched in the Canadian constitution, and in the NWT land claims negotiations (of which hunting, fishing and trapping rights are essential parts) are under way. Though long past are the days when the fur trade dominated the NWT, the future of trapping is far from over.



Ed Hall, NWT Dept. of Renewable Resources.

*Making tea on the barrens.*





## Jack Atatahak

Jack Atatahak was born north of Coppermine at Bernard Harbour (now abandoned) during the winter of 1923. In those days people still lived in snowhouses in the winter and caribou tents in the summer. The only frame structure was the Anglican mission with the RCMP building being constructed at a later date.

Jack received no formal education. He learned the skills for living off the land from his father, who taught him that to survive he had to travel long distances to obtain game. In 1944 he married Naomi, granddaughter of the well-known Central Arctic fur trader, Christian Klengenberg. They raised five children.

In 1949 Jack moved to King William Island where he hunted and trapped by dogteam until 1954. He took up wage employment when the DEW Line was built, working for the next 10 years at different sites across the Arctic (including Cape Dyer on Baffin Island), before returning home to Coppermine. He worked briefly for an oil and gas exploration company in the Beaufort Sea, then resumed his former livelihood of hunting, fishing, and trapping.

Jack, his wife, and two grandchildren now reside at Read Island where they operate a successful outpost

camp, which has been in existence since the early seventies. Jack has devoted much of his time to teaching his grandson the fundamentals of living off the land. This includes not only the basics of hunting, fishing and trapping, but also skills like igloo-building, caching wild game, and care of firearms. He is regarded by many as the most successful trapper in the area. Though he now uses a snowmobile, he still lives much in the same way as his forefathers.

One incident which Jack will never forget occurred in 1950 when he was living on King William Island. He and his wife went polar bear hunting. Upon locating a den, Jack used a snow probe to find the animal within. Suddenly the bear rose up, bursting from its den and giving chase. Jack had his rifle ready but it failed to fire because snow had become lodged in the firing chamber. His wife, who was nearby, coolly sized up the situation, grabbed her own rifle, and shot the bear.

*Fred Elias  
Coppermine 1984*

*Jack and Naomi at Read Island unloading winter supplies from Nassivak.*





## Joanosie Kakee

Joanosie was born in a small camp at the mouth of Touak Fiord on Cumberland Peninsula, Baffin Island, in July 1919. He has never attended school. He married his first wife, Mary Arnaquq, when he was young, and they had two children, Daniel and Achina. Mary subsequently died and in 1949 he married again. His second wife's name is Evic Nakashuklak and they have one daughter, Sineak. They lived out on the land until 1965, when all their sled dogs died in an epidemic. As a result they moved into Pangnirtung, which at that time consisted of a Hudson's Bay post, an RCMP detachment, a hospital, an Anglican mission, and several other families. Although Joanosie has lived in Pangnirtung ever since, he earns his livelihood almost solely off the land. Occasionally he supplements his income by producing small carvings.

He used a dogteam until about 1975, when he switched to a snowmobile. He recalls his dogteams

with a great deal of pride. He used to run 20 dogs and as a young man always felt superior to other hunters because his dogs were strong and healthy.

In 1968 Joanosie contracted tuberculosis and had to spend three-and-a-half years in a hospital in Hamilton, Ontario.

In 1980 while on a hunting trip at Kingnait Fiord with three other hunters, he was attacked and mauled by a polar bear. After a struggle that resulted in Joanosie sustaining many wounds, including a half-torn-off scalp, the bear was finally shot by one of the other hunters.

Joanosie is a renowned polar bear hunter and has many other exciting stories to tell.

*Winston Fillatre  
Pangnirtung 1983*





## Johnny Neyelle

Johnny Neyelle was born in old Ft. Wrigley in 1915. He received three years schooling at the Roman Catholic mission in Ft. Providence before his family moved to Ft. Norman in 1931. Ten years later he married his first wife, Rosie Yukon. She, and four of their five children, subsequently died of tuberculosis. In 1950 Johnny married Jane Kenny, daughter of patriarch Joe Kenny, and two years later they moved to Ft. Franklin. At that time the community consisted of a few log houses and a Hudson's Bay store, with a church and school under construction.

Johnny has lived in Ft. Franklin ever since, earning a livelihood almost solely off the land. A renowned moose hunter, he prefers to hunt alone and still uses a Winchester Model 64 .30-30 which he bought in 1939 for \$65. Although he uses a snowmobile in winter, he still travels by dogteam when he goes on the annual spring hunt for beaver and muskrat. In summer he

likes to fish for grayling along Bear River, while August is a favourite month for hunting moose. Skilled with axe and knife, he has made his own paddles, axe handles, snowshoes, toboggan boards, and has occasionally carved figures for sale as handicrafts. He once made a violin, which is currently on display at the Prince of Wales Northern Heritage Centre in Yellowknife.

Among his most memorable experiences he rates high the two times he hunted as a youth in the Mackenzie Mountains with Ft. Norman folk, going after moose, caribou and sheep in the summer, using dogs to pack supplies, and returning home in mooseskin boats made for the occasion.

*Ed Hall  
Ft. Franklin 1983*

# Making Snowshoes

Made by Johnny Neyelle, Fort Franklin, 1983

Text by Ed Hall

Photographed by Tessa Macintosh

Snowshoes are a necessary item for anyone living and working in the bush. Although most people now buy them, a few still make their own. Johnny Neyelle of Ft. Franklin is one such person. The following is a description of how he made a pair in August 1983. It took him six days: one day to select the wood and shape the frames, two days for the wood to dry, and three days to complete the job. The snowshoes he made were a standard working pair for a person of his size (less than 70 kg). For hunting in the spring when the snow is wet, much larger snowshoes are needed.

Snowshoes can be made at any time of the year. Johnny said that birch is preferable to spruce because it is easier to work with and makes a nicer job. However, birch growing on dry soil cannot be used because it is too stiff; only birch in swampy areas should be employed. If spruce is used, care must be taken to select white spruce and not black spruce.

Johnny did not follow any plans as he made the snowshoes. The pattern was entirely in his head.

## Materials Used

4 white spruce saplings 1.5 m long  
1 piece of wood for a spacer  
6 pieces of wood for crossbars  
babiche, sideline, twine  
sandpaper

## Tools Used

axe  
clasp or belt knife  
crooked knife  
electric drill with 1/8 in.(3 mm) and 1/4 in.(6 mm) bits  
handsaw (crosscut)  
palm gouge (made from a screwdriver)  
lacing needle (made from a hacksaw blade)  
tape measure  
visegrips  
plane  
vise





4 Holding each set of poles together at the toe he marked them about 25 mm down from the tips in order to cut a notch on the outside of each pole. The notch was deep, about halfway through the pole. Using visegrips, the toe of each pole was bent at the point where the notch was made. (7,8)

Each pair was tied together with babiche at the notches, and again at the tail with sideline. The poles had to be perfectly flush in the two places where they were tied. It took a bit of twisting and bending to get them this way. They were tied together as tightly as possible. (9)

5 Johnny inserted a wooden spacer about 20 cm long between one pair of poles. To make sure he did not apply too much pressure on the notched toe, he tied a safety line around the poles about 20 cm down from the tip (before inserting the spacer). (10) This prevented the poles from separating any more than about 12 cm or so where the safety line was. This meant that when the two poles were drawn apart to insert the spacer, they bent not only at the toe and tail, but also at the place where the safety line was. (11)

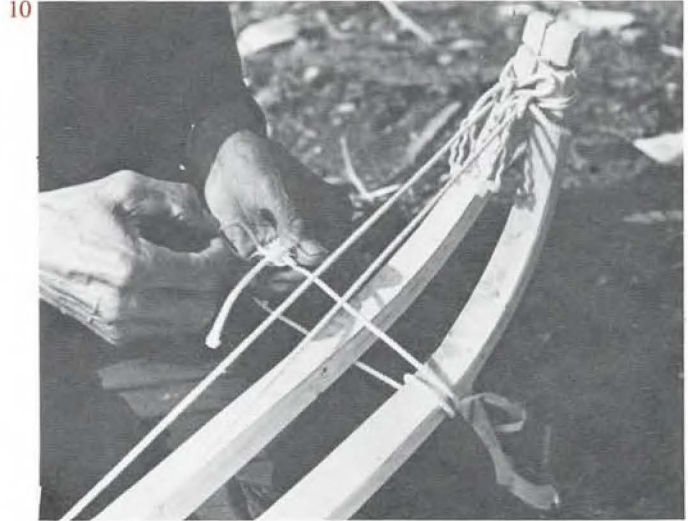
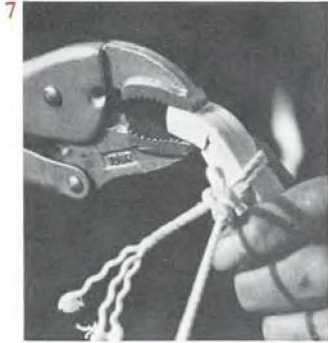



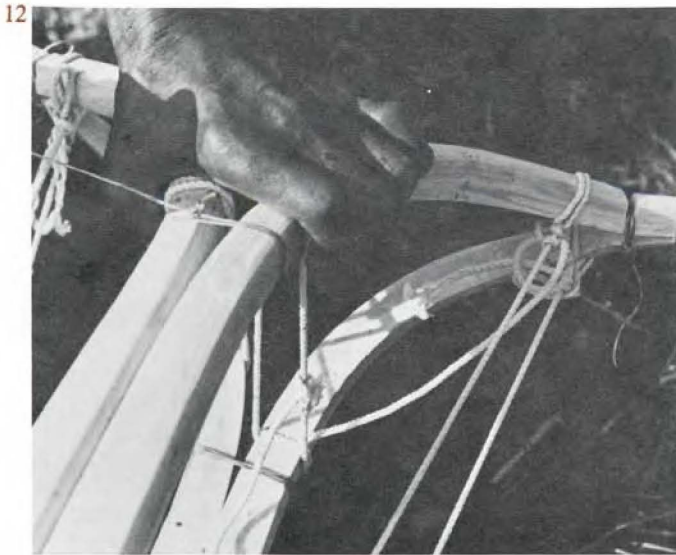

By putting the two frames back to back, the same spacer was used for both. They were then tied together and hung up to dry in a warm place for two days. (12,13) While the wood was still green, the strings holding the upturned toes were taut. When the wood was dry, the strings became loose.

## B. Preparing the Frames to Receive Crossbars and Webbing

- 1 Johnny separated the two frames and removed the four pieces of sideline which had been used to hold the upturned toes in place. With the poles now dry, these pieces of string were no longer needed. He set aside the piece of wood used to brace open the frames, as this would be used again in step C1.

Using a 1/8 in.(3 mm) bit, Johnny drilled two holes in the tail of each frame, just before the two sides joined to form the crotch. The holes were drilled completely through both sides of the frame and positioned diagonally to each other. (14)

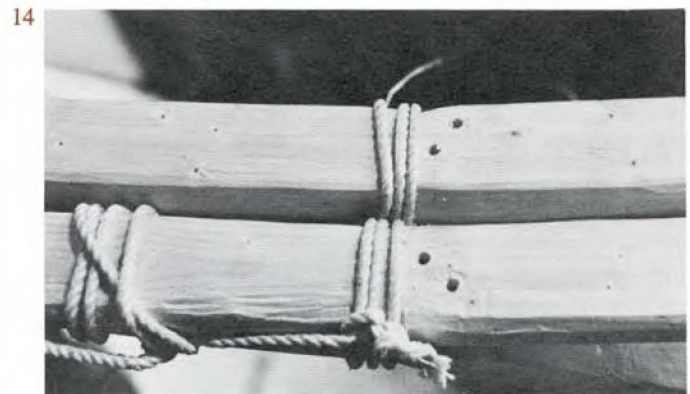

- 2 Johnny marked the positions of the three crosspieces. He allowed a space of 33 cm between the middle and tail crosspieces, and used a tape measure to ensure evenness of placement. The toe crosspiece was located just past the point where the toe began to curve upwards.



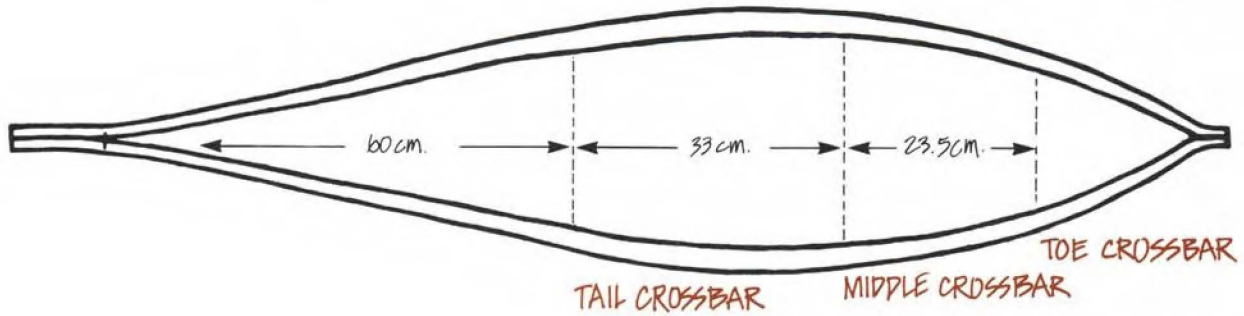

3 Both frames were cut apart at the tail and toe in order to make the slots for the crosspieces. Each slot was made by drilling two holes with a 1/4 in. (6 mm) bit on the inside of each pole. The holes were drilled a touch less than halfway through, then the wood between the holes was gouged out. (15) The length of each slot was as follows: toe 19 mm, middle 38 mm, and tail 38 mm.

Johnny then made a shallow slot on the outside of each pole at the tail between the two diagonal holes which had been drilled in step B1. These holes went completely through each pole; the slots however were only deep enough to receive a few strands of babiche — no more than one-quarter of the way through the pole.

4 Johnny drilled a series of holes on the inside of each pole using a 1/8 in. (3 mm) bit. The holes were drilled in pairs at an angle so that they intersected each other. (16) Johnny always drilled the bottom holes first. He held the drill at about a 30° angle.

Between the toe slot and the notch at the end of the toe, the holes were drilled slightly differently. Only one hole of each pair was drilled on the inside of the pole. The companion holes were drilled on the underside of the pole. As before, the holes were drilled only deep enough to intersect each other. (17)

After all holes had been drilled, Johnny sanded down the poles with sandpaper.

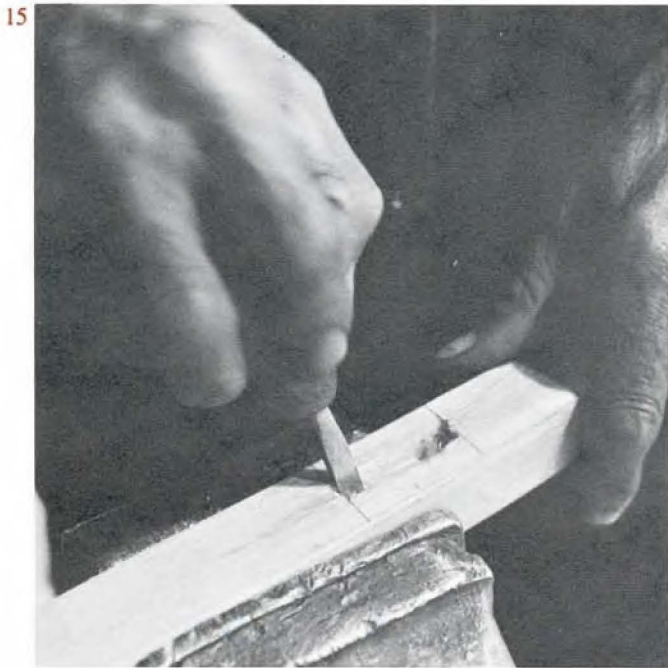

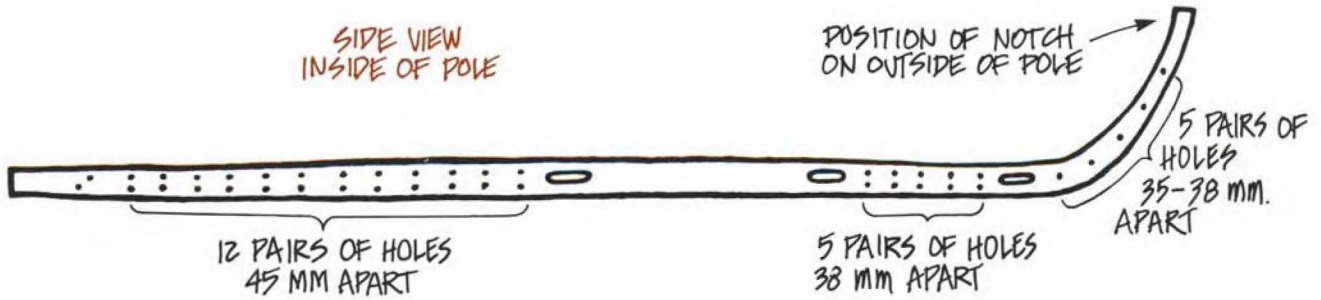

17

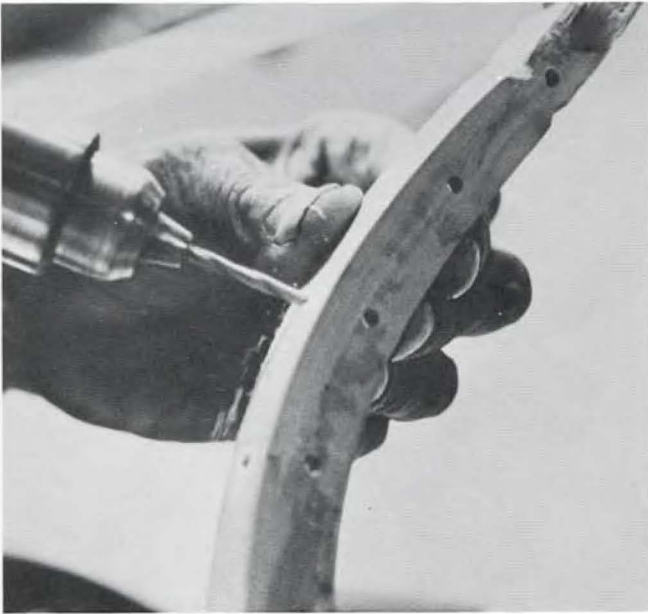

5 Johnny prepared babiche for use by moistening it slightly and running it between his thumb and the back of a knife blade or the edge of a spoon handle. This helped to make it flexible and straighten out twists. The babiche was run through the holes which had just been drilled. Johnny always inserted it through the top hole first, and worked it back and forth through the two holes several times to soften it up further and work out any twists. The illustration below shows where Johnny began and the order in which he proceeded.

- a) Johnny laced the tail section of one pole.
- b) He laced the front end of the two poles, tying them together at the notched toe in the process.
- c) Picking up where he left off in (a) and using the same length of babiche, he tied the poles together at the tail and completed lacing the tail section of the other pole.

Both toe and tail were drawn together and tied as tightly as possible.

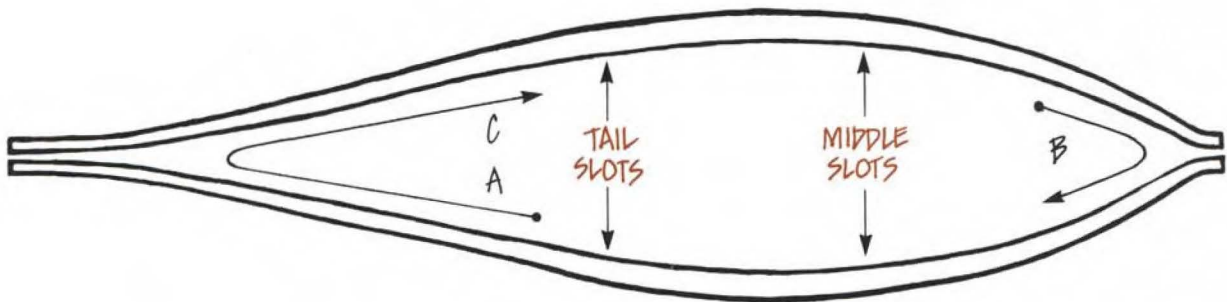



The method of lacing was the same throughout.  
(18-20)

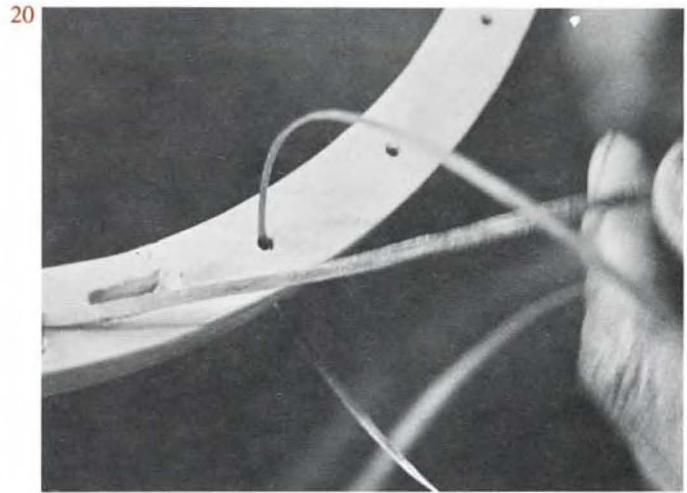
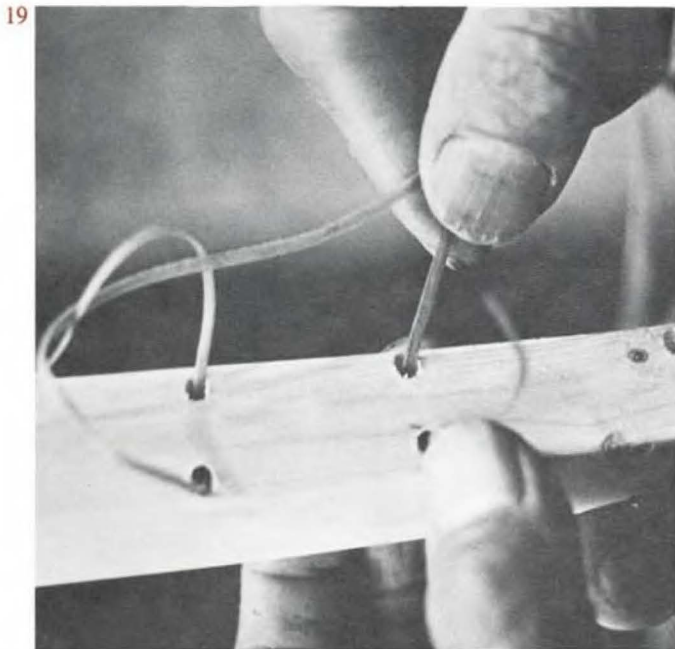
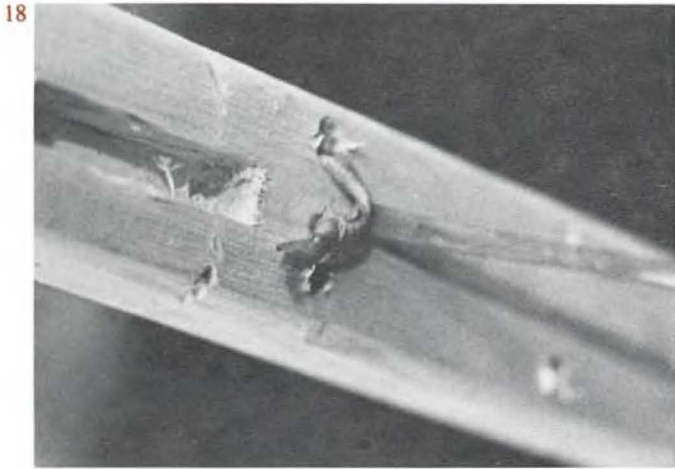

6 In order to get a good tight fit, it was necessary to trim one corner off the tip of both poles.

The poles were tied together at the toe in the following way:

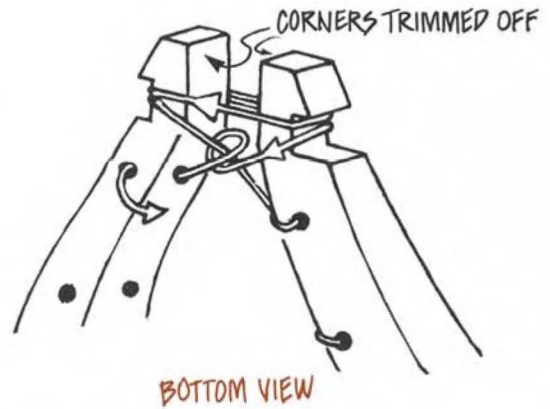

7 The poles were tied together at the tail in the following way:

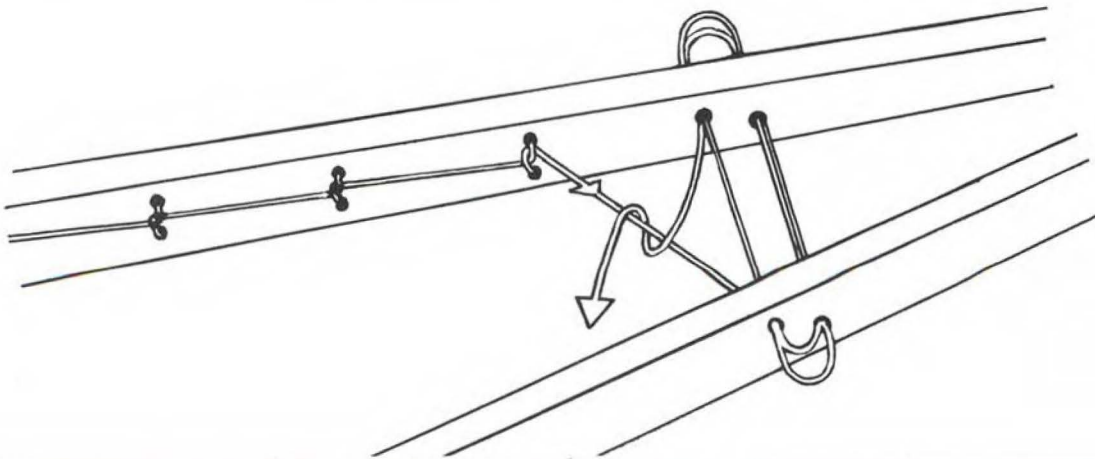

## C. Making the Crossbars

- 1 From a block of spruce Johnny cut six pieces of wood for the crossbars. He trimmed and smoothed them to the following dimensions:  
 toe crossbars (2 each) — 1x2x17 cm  
 middle crossbars (2 each) — 1x4x22 cm  
 tail crossbars (2 each) — 1x4x20 cm

A safety string was tied around the toe where the toe crossbar was to be placed. The frame was braced open in the middle using the same block of wood which was set aside in step B1.

The middle crossbar was the first one to be fitted. The ends were cut off exactly using a hacksaw, and trimmed down in width and thickness to fit into the slots in the frame. The spacer was removed and the crossbar inserted. (21) The frame was pressed together to wedge the ends of the crossbar firmly into place. No glue was used.

The safety string was removed and the toe crossbar fitted in the same way as the middle one. Once the piece was in place, the safety string was tied around the toe again. Finally the tail crossbar was fitted and put in place.

- 2 Several centimetres up from the toe crossbar towards the toe, Johnny strung a length of babiche between the two sides of the frame, employing existing holes or drilling new ones if needed. He looped the babiche twice through the holes and drew it tight (22), then he wound babiche around the two strands to strengthen them.

21



22

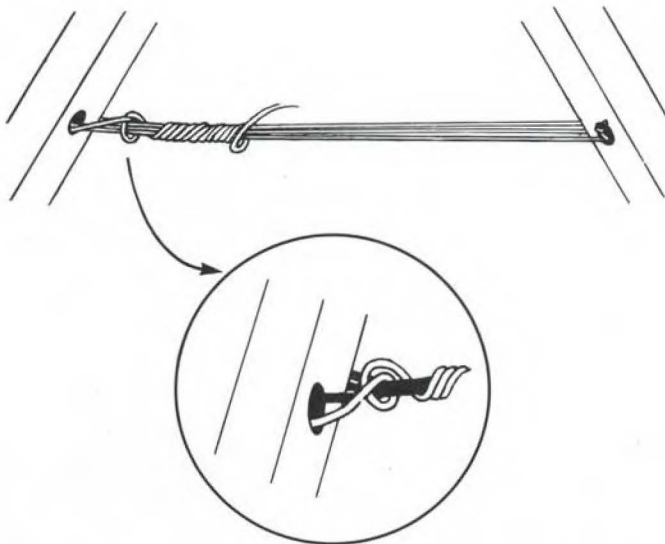
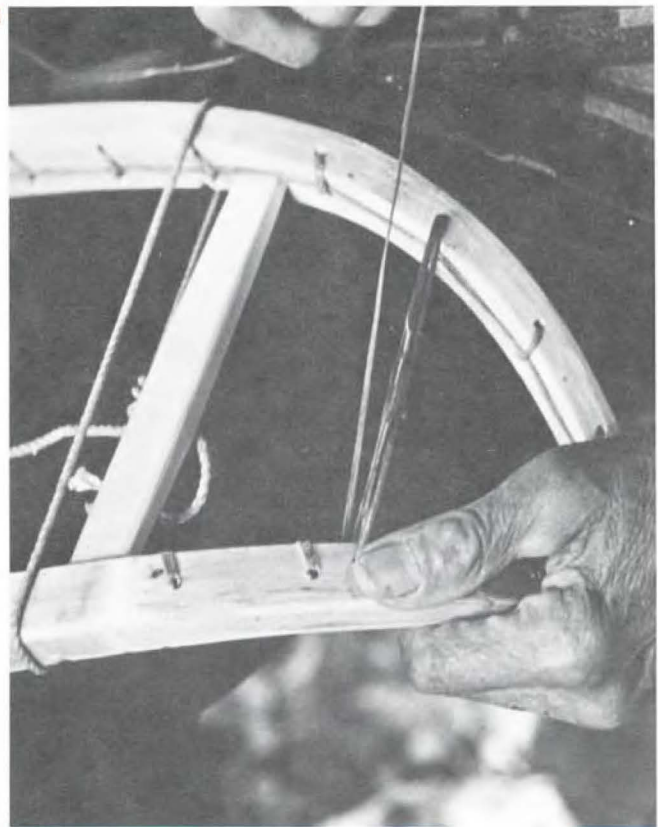

The purpose of this was to reinforce the toe and keep the toe crossbar from popping out. The safety string was then removed.



3 Using a 1/8 in. (3 mm) bit, Johnny drilled two holes completely through the tail. He cut two square wooden pegs and tapped them through the holes. He trimmed the ends off flush with the frame on both sides. (23)

He cut off the tail with a crosscut saw and bevelled the edges with a knife. He cut off the toe with a hacksaw and bevelled the edges with a knife. (24,25)  
Photo 26 shows one frame completed to this point and one still awaiting the steps in this section.

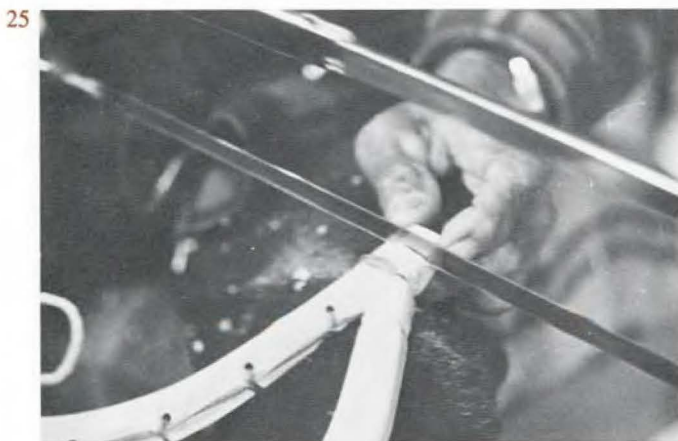

## D. Webbing the Toe Section

1 Johnny drilled five holes in the middle crossbar using a 1/8 in. (3 mm) bit. (27) Then he prepared the babiche as in step B5. To install the webbing he used a "needle" made from a hacksaw blade; both ends were rounded and the eye was simply a hole drilled through one end.

Johnny began by tying a loop around the middle crossbar on the righthand side. The babiche went up to the toe, back down to the middle crossbar on the lefthand side, then across to the right side where it was looped around the crossbar again. This basic pattern was repeated, with modifications, until the webbing was complete. (28-33) The babiche always went *under* the toe crossbar and the babiche reinforcement at the toe.

27

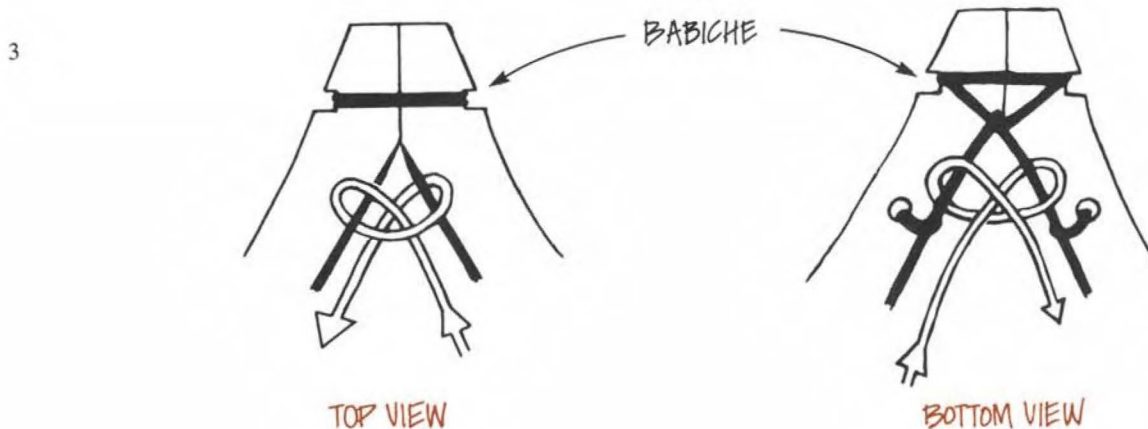
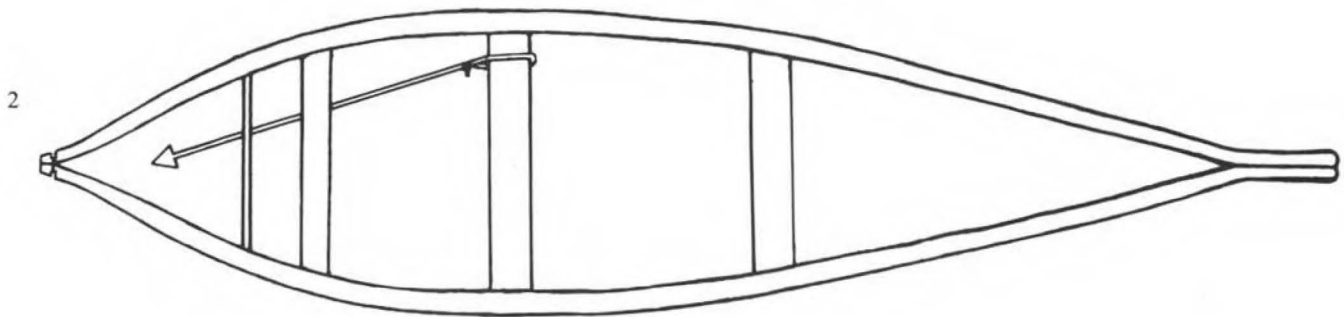



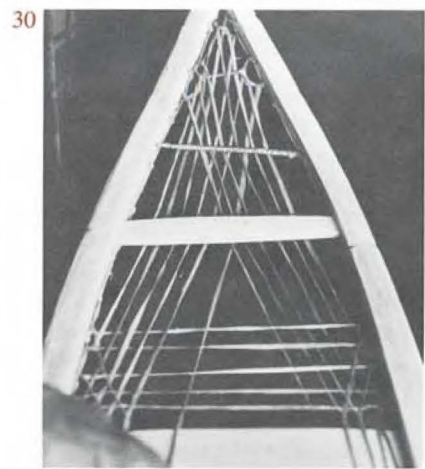

4 All remaining drawings in section D are shown from above, or "top views".

5

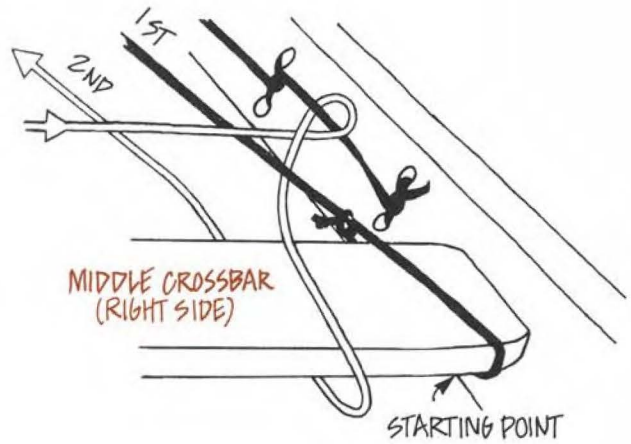
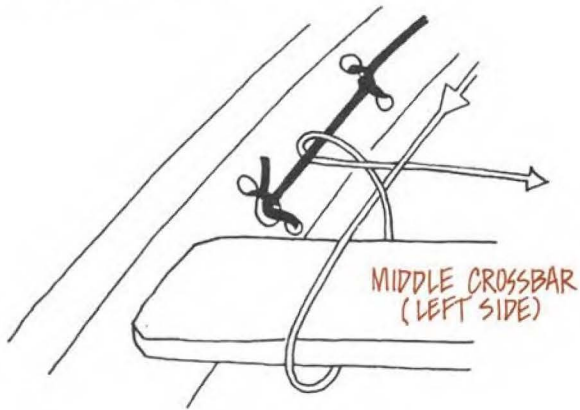

6

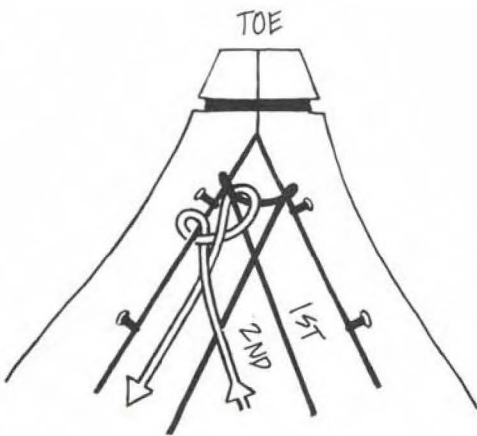

7

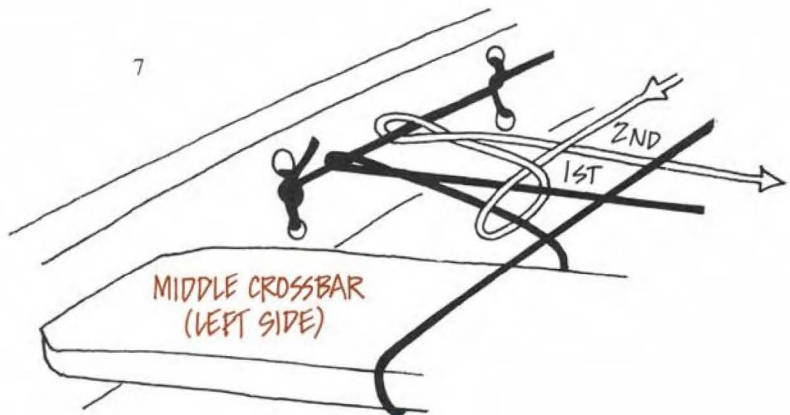

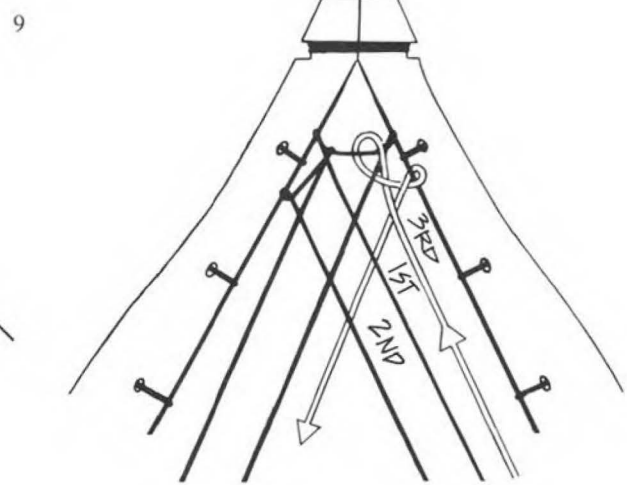
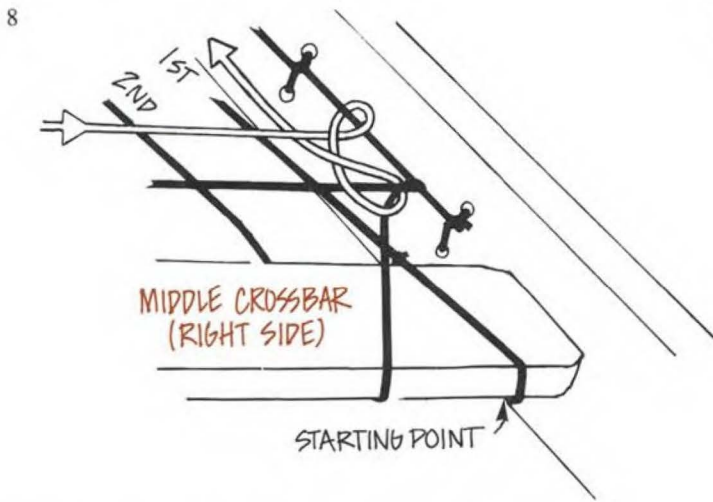
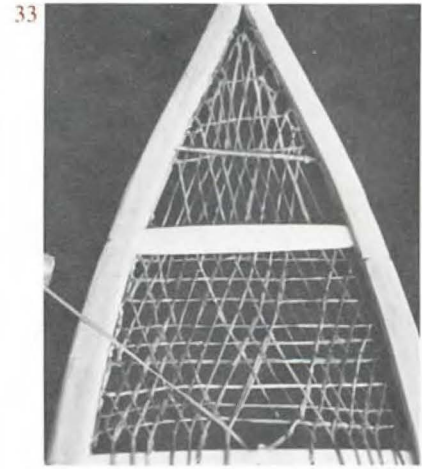
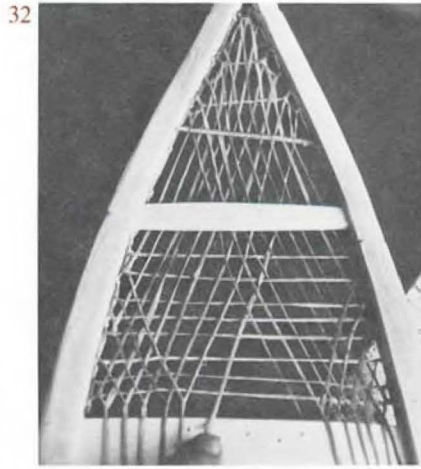

10 Throughout the entire toe section, each side lashing received and held two strands of webbing, no more.

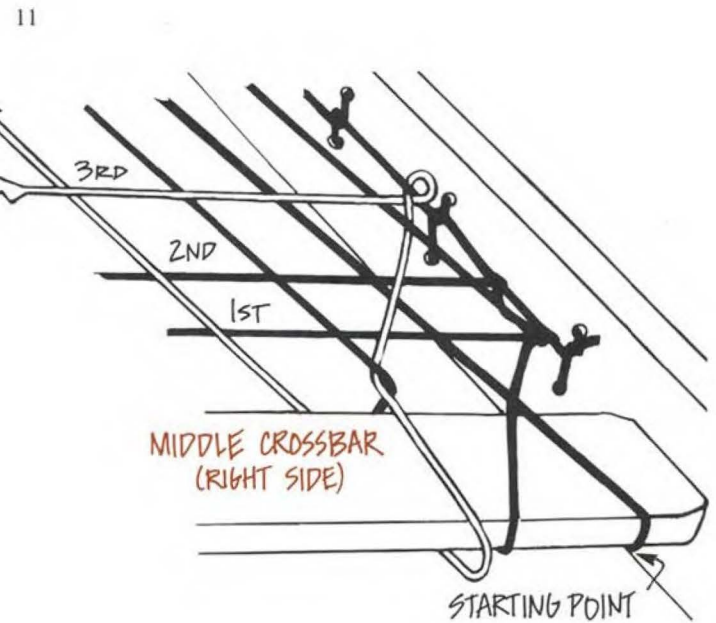
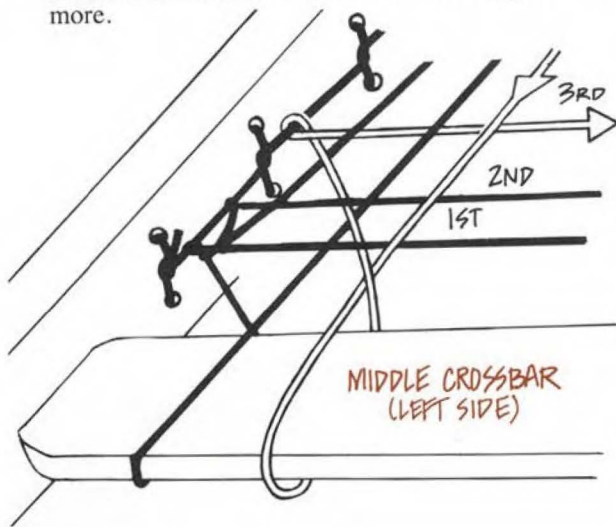



12

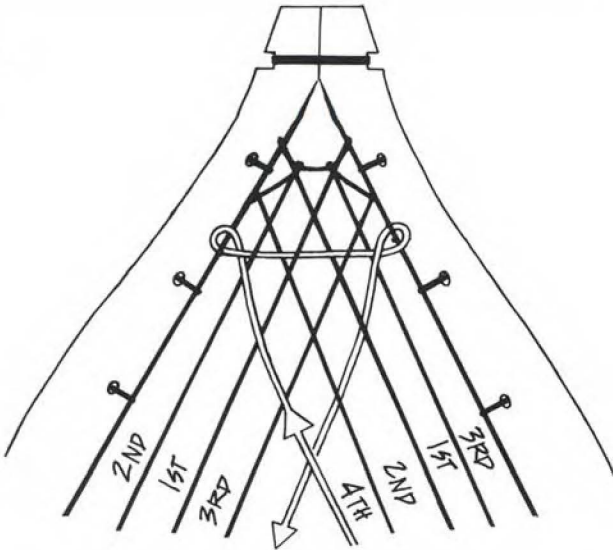

14 The pattern in steps 7 and 8 was repeated. At the toe the next step was basically a repeat of step 9.

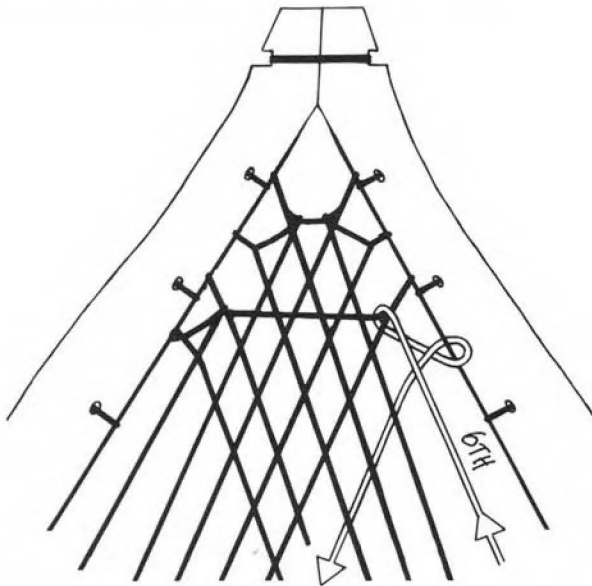

13 The pattern in steps 10 and 11 was repeated. The next step was basically a repeat of step 6.

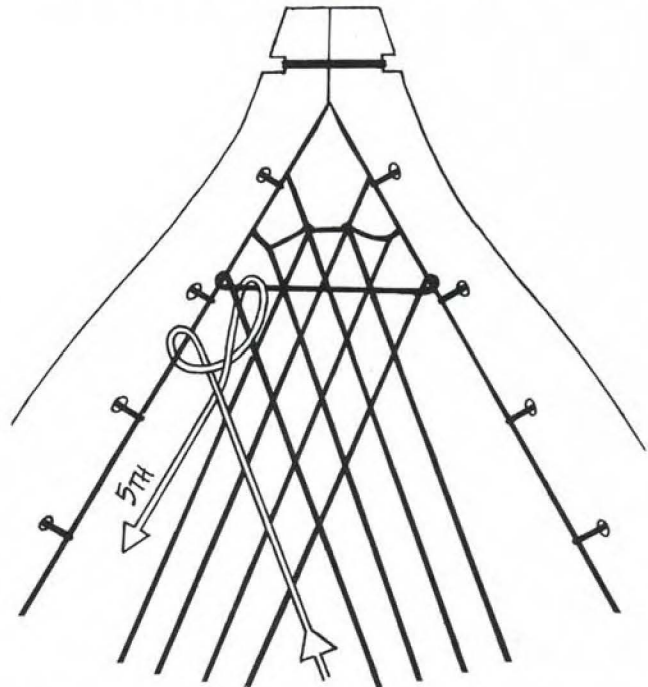

15 These patterns were repeated until the webbing was complete in the toe section. Each new strand was woven through the others to form the webbing. When more babiche was needed, Johnny simply tied another piece to the end of the one he was using. First, however, he rubbed ashes on the moistened babiche to keep the knot from slipping. As the webbing reached the centre of the middle crossbar, it was passed through the five holes drilled in D1. The webbing was finished and tied off at the centre of the crossbar. (34)

34

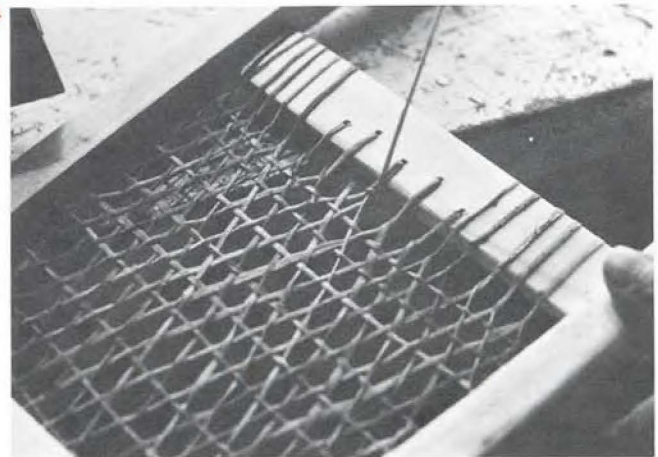

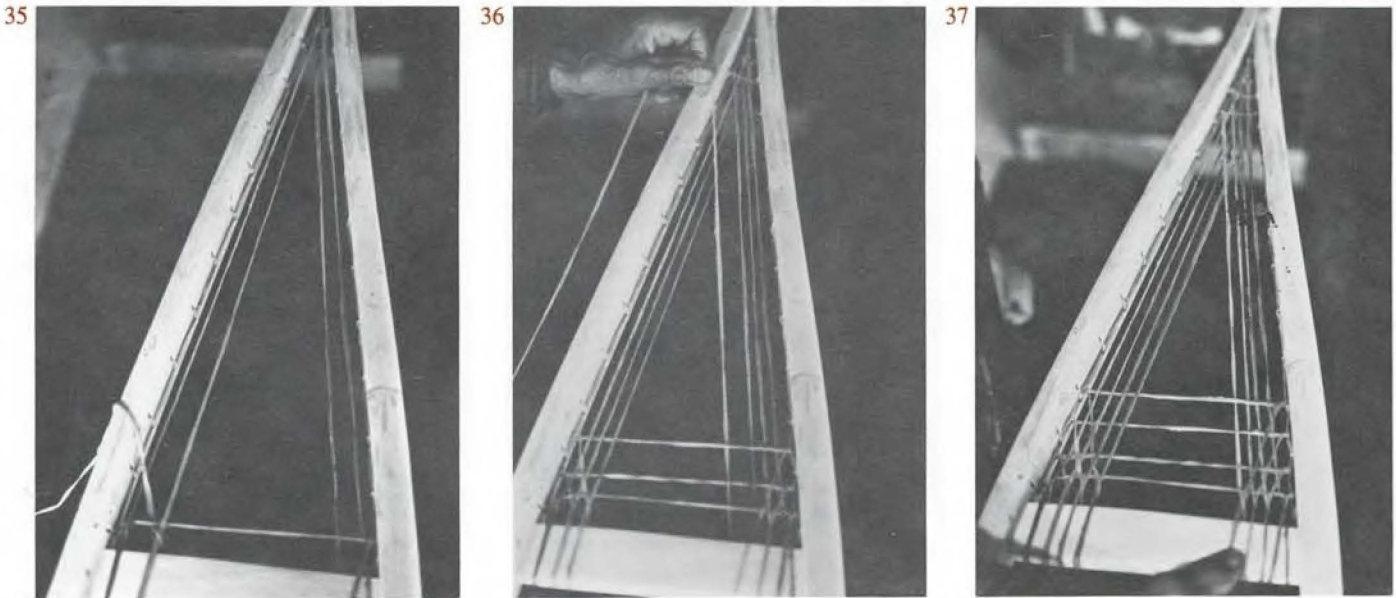

## E. Webbing the Tail Section

1 Johnny started the webbing on the lefthand side of the tail crossbar. The babiche went to the tail crotch, back up to the righthand side of the crossbar, and across to the left side of the crossbar. This basic

triangular pattern was repeated until the webbing was complete. As with the toe section, new strands were woven through existing strands to form a web. (35-40) Note: all illustrations in this section are shown from above, or "top views".

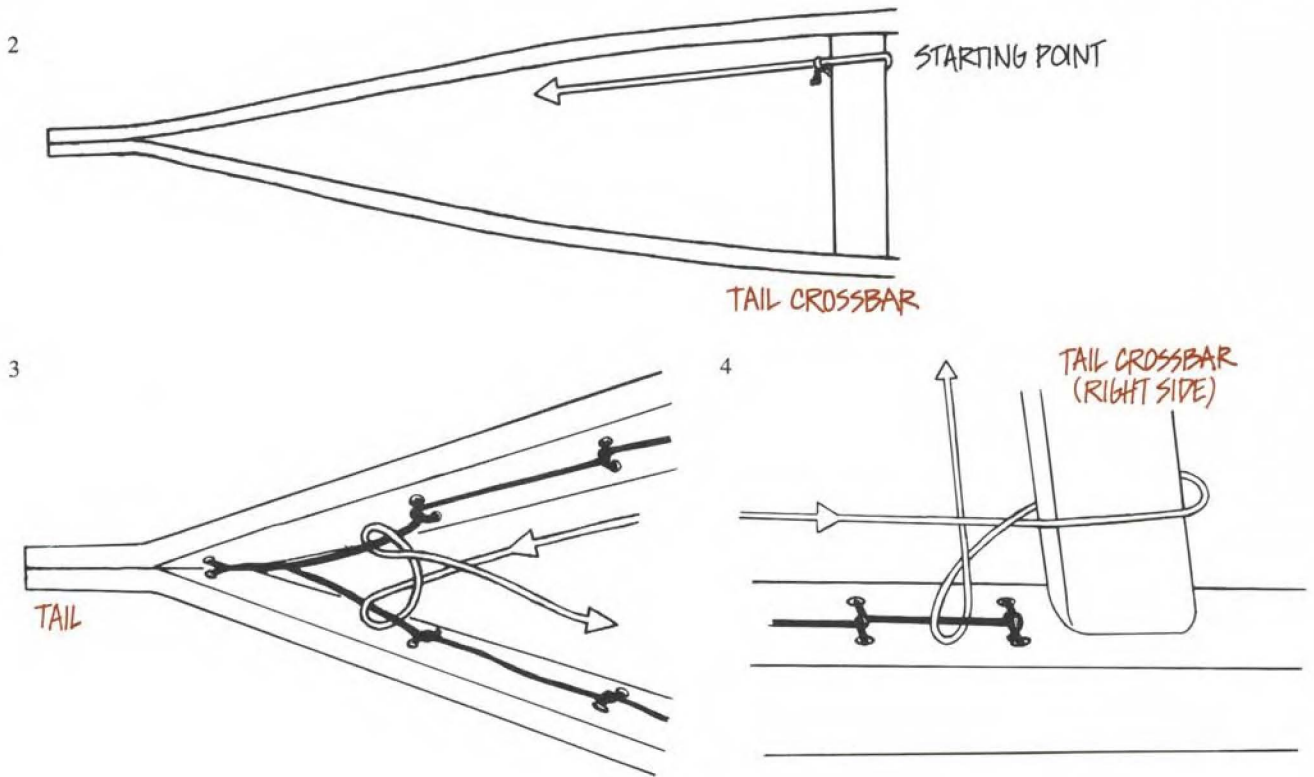



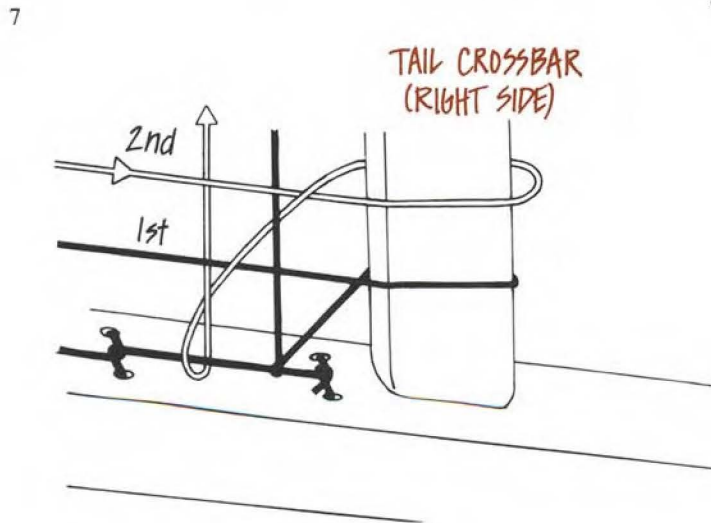
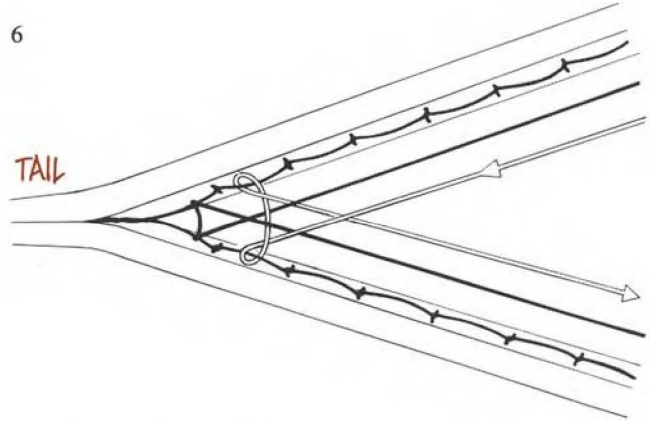
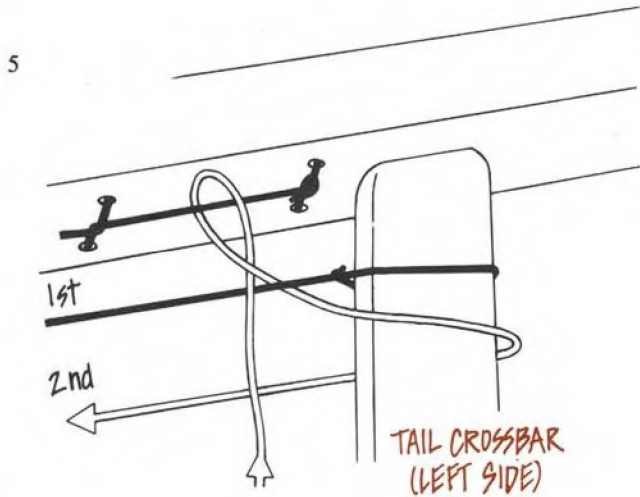
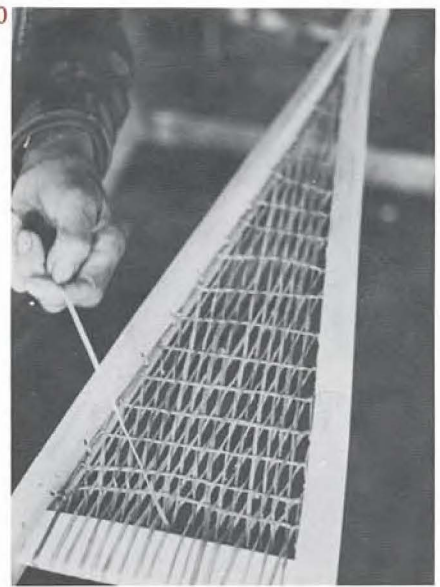
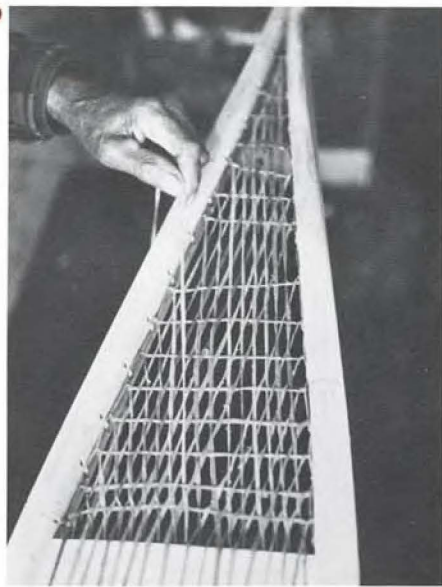

8 Johnny followed this pattern until the webbing was completed. In some cases the side lashings received and held only one strand of babiche, but never more than two.

## F. Webbing the Middle Section

- 1 The middle section is where the entire weight of the body is placed with each step. Not only was the wood thickest here, but also no holes were drilled in this part of the frame. In two places (*a* and *b*) Johnny tied eight strands of babiche across the frame, as shown. Then he began the webbing with a single strand.
- 2 All drawings in this section are viewed from above, except for no. 12 and 13.

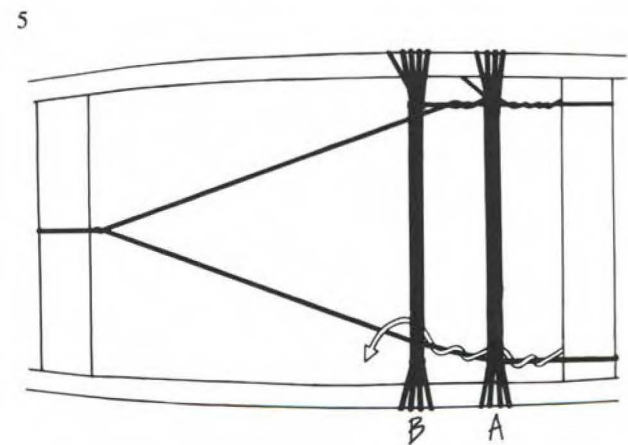
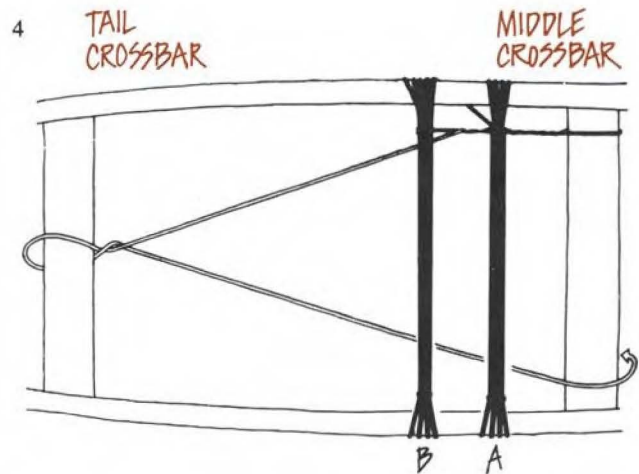
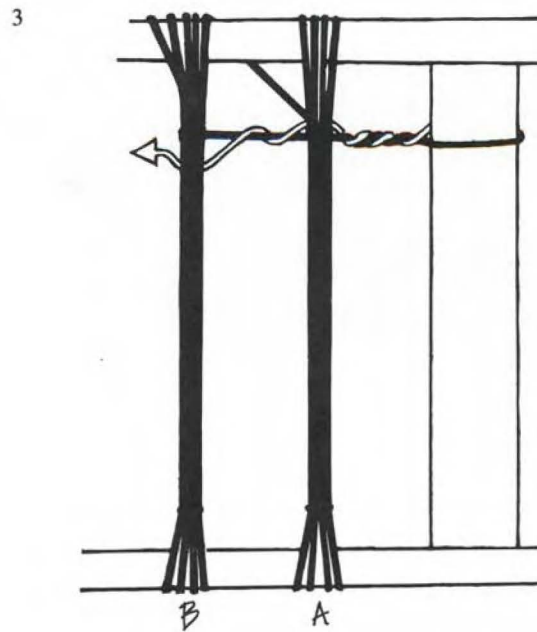
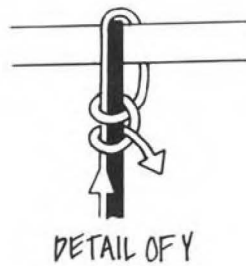
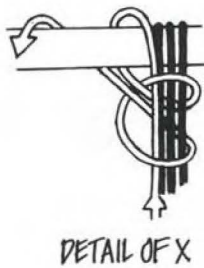
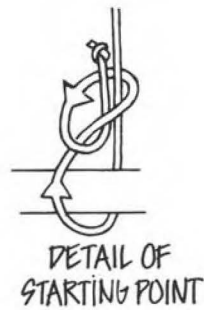
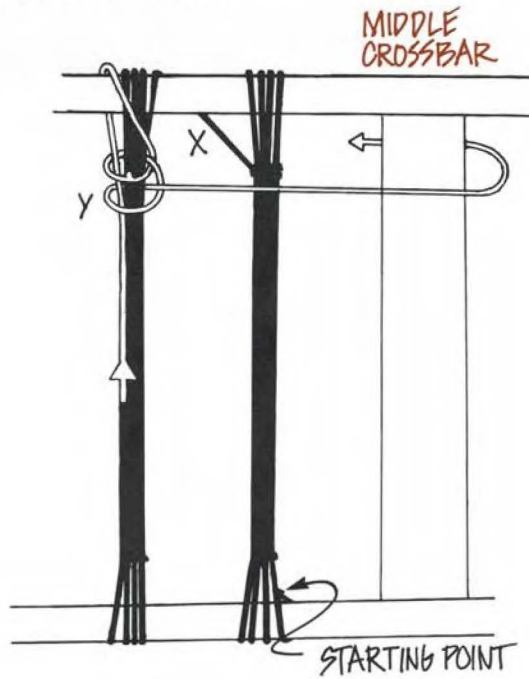



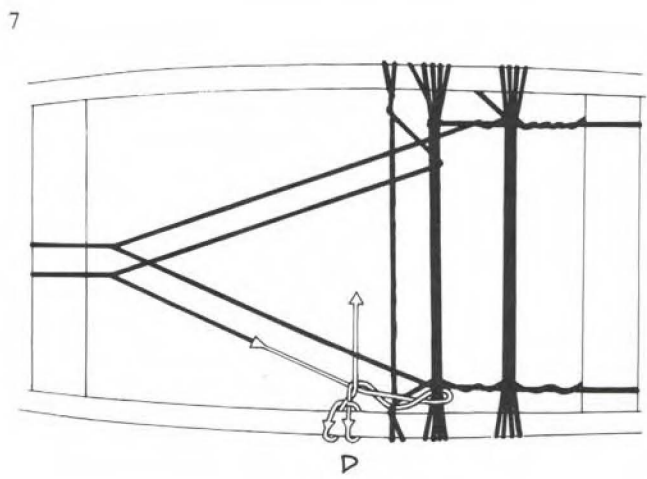
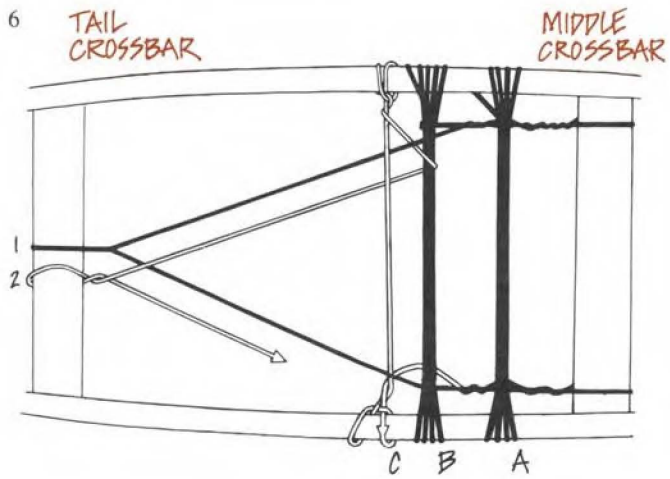
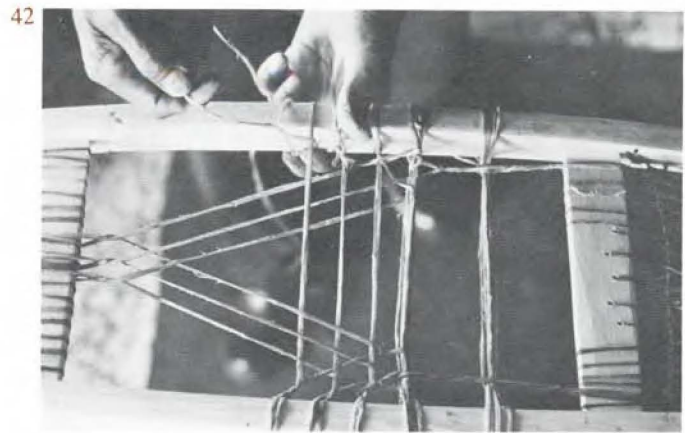
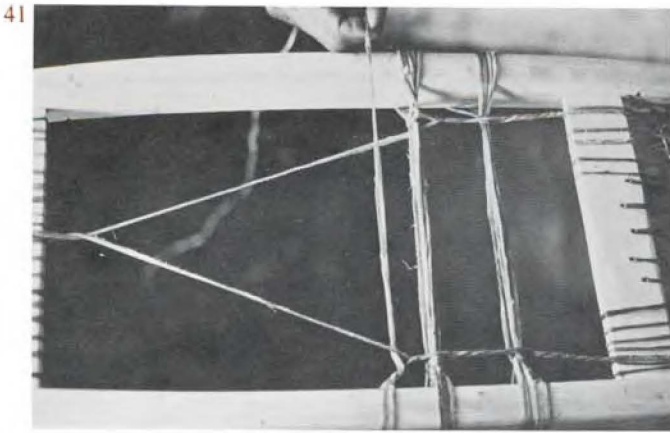

8 This step was a mirror image of step 7.

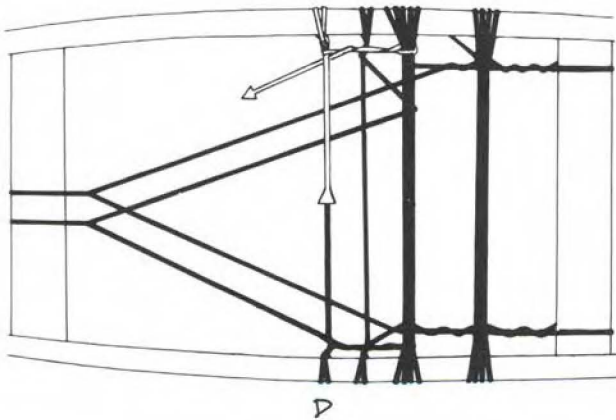

9 Each new strand was woven through existing strands to form a web.

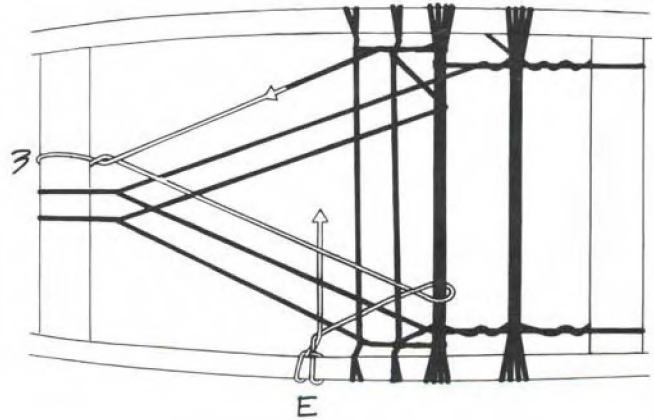

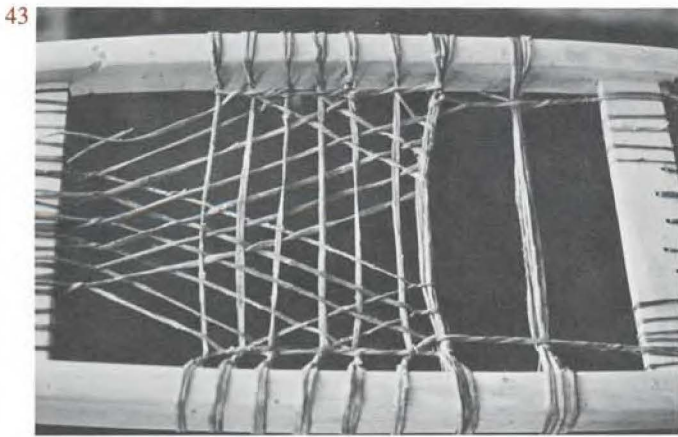

10 This step was a repeat of step 7.

11 The pattern repeated itself until the webbing was complete. (41-43)

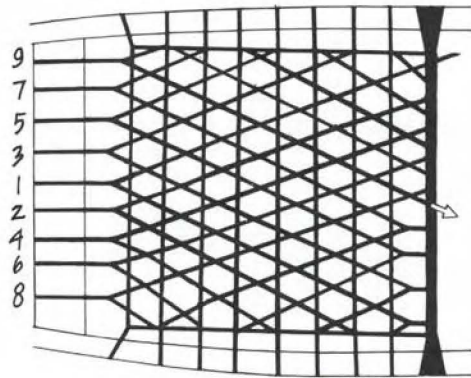
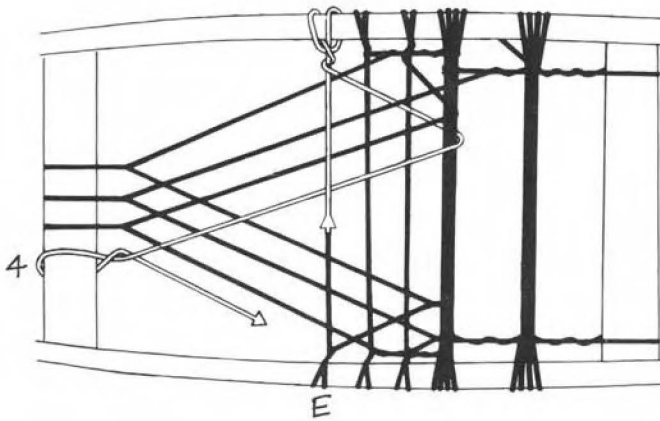

12 A strand of babiche was looped over *a* and drawn back to the tail crossbar. This was repeated until six or eight strands linked the tail crossbar and *a*. All strands passed underneath the webbing, but half went over the top of *b* and half went under. Enough tension was exerted on *a* so that four fingers or a hand could be inserted between *a* and the middle crossbar. (44, 45)

13 Johnny added two more such bottom lashings to strengthen the middle part of the snowshoe.

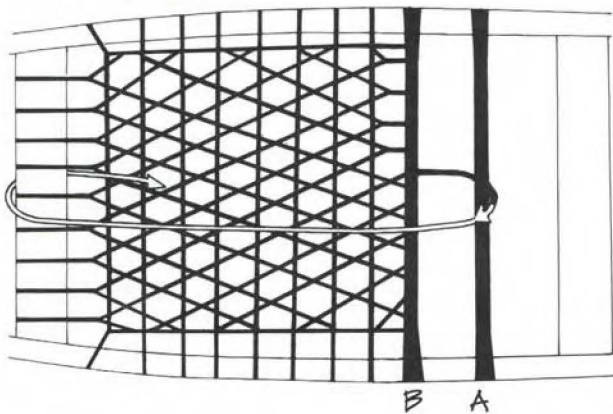

BOTTOM VIEW

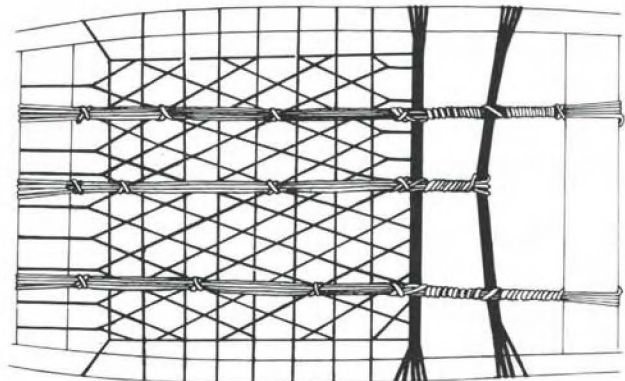

BOTTOM VIEW



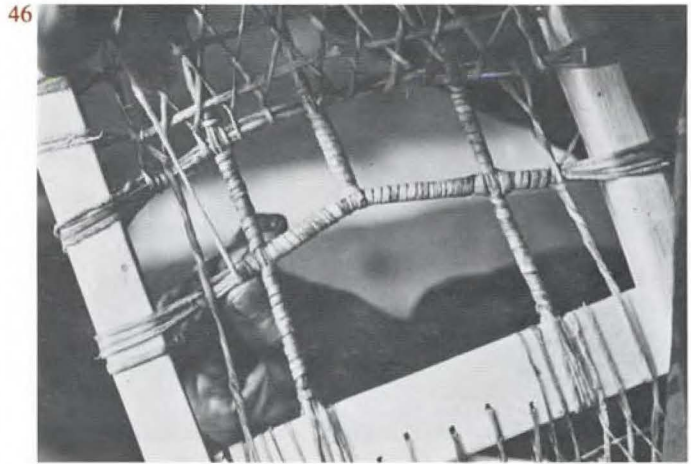
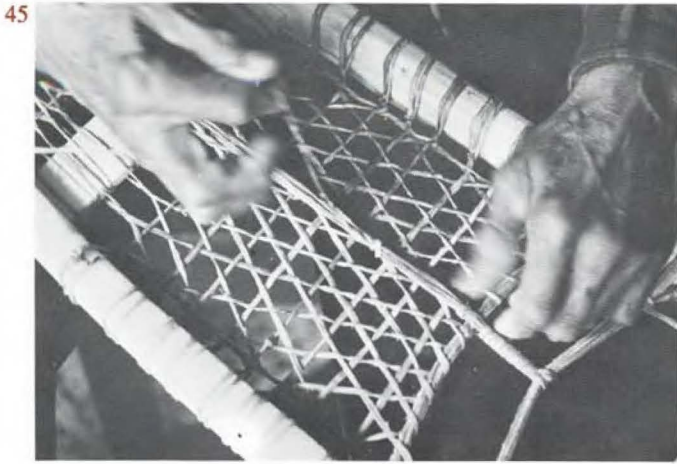

14 He then wrapped babiche around those strands shown in photo 46.

15 Photo 47 shows one snowshoe completed and one awaiting crossbars and webbing.



## G. Fixing the Harness

1 Johnny used a strip of tanned moosehide 137 cm long for each harness. He cut two slits 38 mm long at one end about 30 cm apart, and tied it as follows: (48-53)

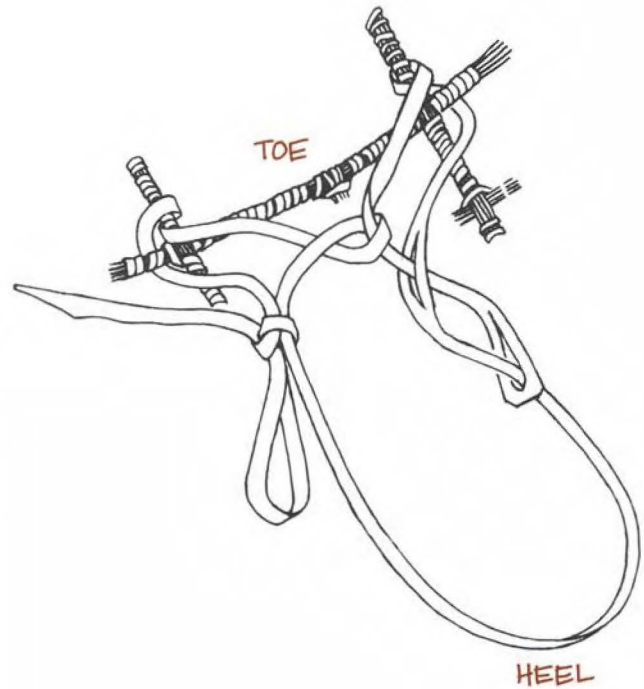

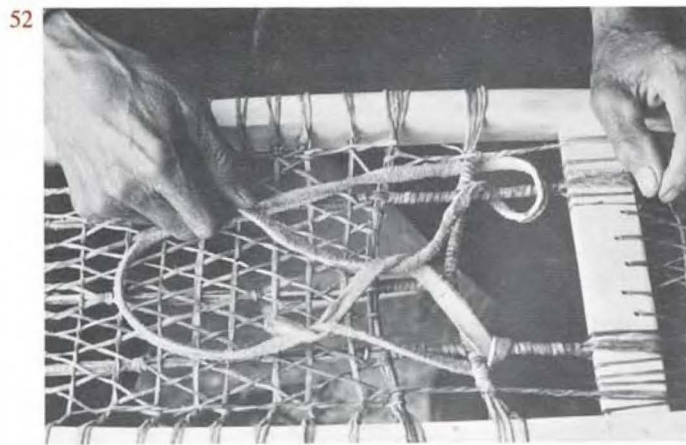
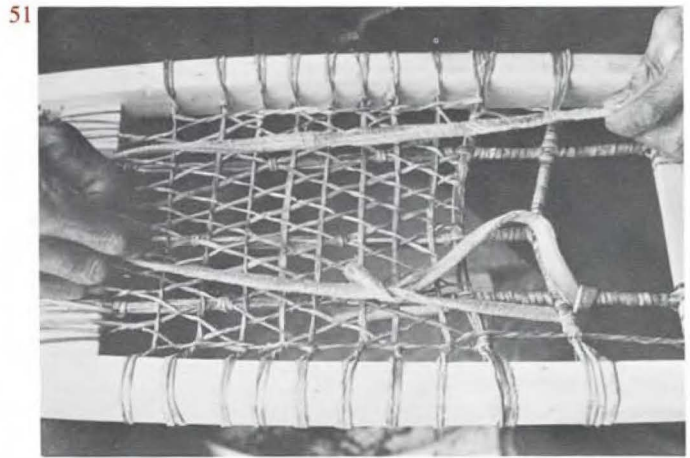
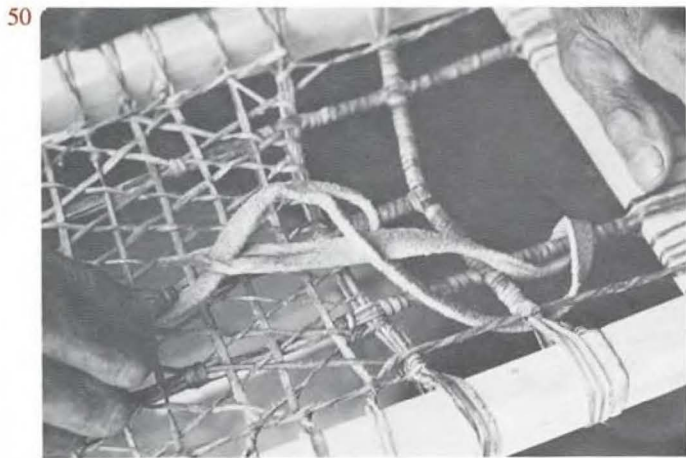
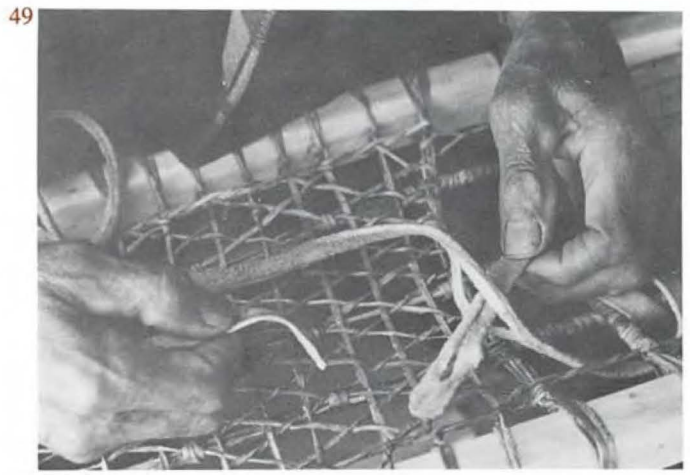
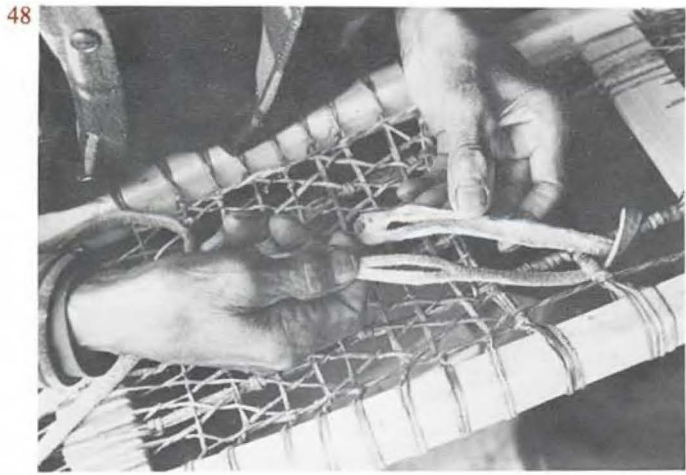



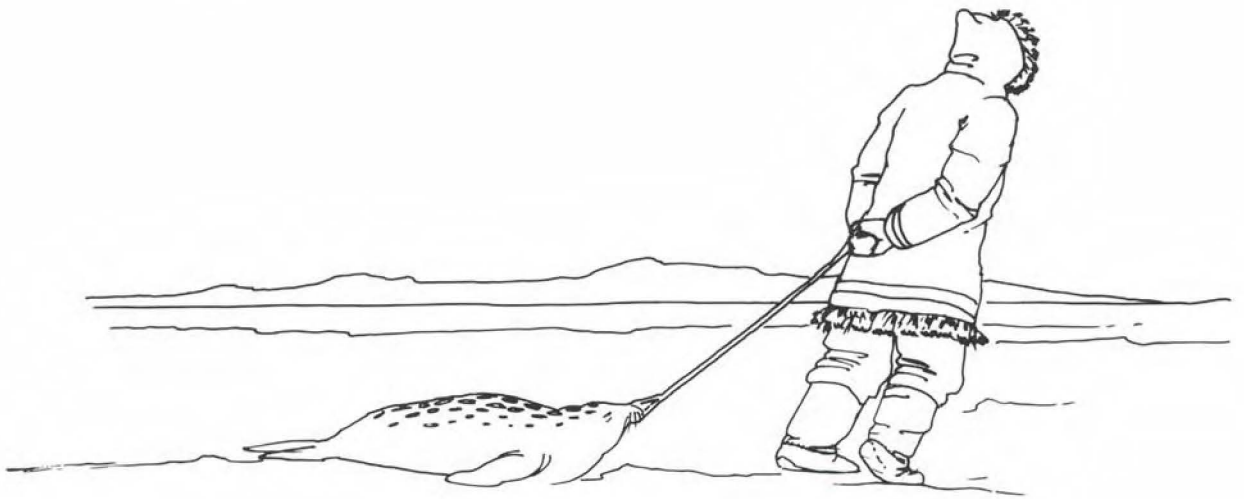

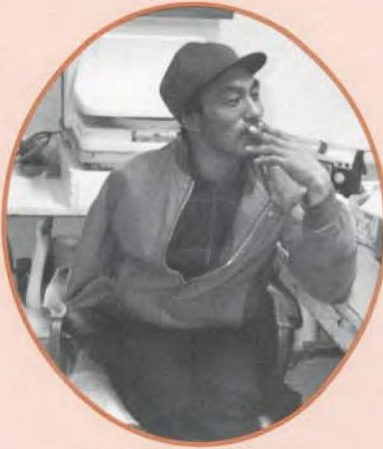

## Aiyout Inuk

I was born on the 5th of July, 1945, somewhere near Arctic Bay at the north end of Baffin Island. When I was still fairly young, we moved to Creswell Bay on Somerset Island. I remember tasting a little bit of whiteman's food there, but mostly I remember eating seal meat and bannock. Later we moved to Ft. Ross.

My father had a dogteam and he had to hunt full-time to feed them and the rest of us. We depended on the dogs to survive, so my father had to kill many seals to keep them fat and healthy. All winter and spring the only meat we had was seal.

In those days we had very little fuel oil and could not use it all the time. Throughout the winter, we heated our home, dried our clothes, and melted snow with a seal oil lamp and burnt blubber in a homemade stove. When seal oil was running low and white foxes were very fat, we would burn the fat in our stove, but this did not happen too many times.

I learned how to hunt by going out with my father. I remember being very young, waiting at a breathing hole and watching my father. That is the best way to learn — to go out with someone. In the fall we hunted at the floe edge and in the winter we hunted at breathing holes in the ice. We tried to catch as many seals as we could.

Beluga whales were easy to hunt, even though we had no motor for our boat and did not have many bullets. We would find a high point of land along the shore and wait for the whales to approach. Then we would shoot behind them and they would swim into shallow water and dive to the bottom. By waiting very quietly and not disturbing them any further, they would finally surface for a breath of air and not move away. That was the time to shoot. Now I hear belugas are harder to kill. They say once they know people are around they run away to deeper water.

We hardly ate caribou meat in those days. We only ate it in the summer. My father used to walk and hunt. Sometimes we waited two weeks for him to come back with caribou meat.

I remember the first time I saw a polar bear in Ft. Ross. I was a young fellow. I was afraid of the bear even after the dogs chased it and had it under control. I was especially afraid when it turned its face and looked at me, but I had to stay and help my father.

We also trapped white foxes when the season opened up in the fall. This is what we bought our supplies with. Almost every day we would be working, checking our traps especially when the weather was stormy, because when it was calm we hunted seals. This is the way it should be. Everybody should work for a living.

After we had lived in Ft. Ross for a while the Hudson's Bay Company closed its store and everyone moved to Spence Bay except for a few of us. We stayed at Ft. Ross and did okay, even though we did not have very much equipment. Finally we decided to move to Spence Bay because getting supplies was time-consuming and involved too much travel. Another reason was that I married a lady from Spence Bay and did not want to take her away from her parents.

Later on we moved to Thom Bay, which is about 50 miles northeast of Spence Bay. There I trapped white foxes and got a little work from the government. They paid us to build a freezer in the ground, and to pick up whale bones for carvers to use. We were paid \$300 per month, it seemed like a lot of money in those days.

Finally we moved back to Spence Bay and I worked as a carpenter building houses, then I drove a truck for the Co-op. After a while I lost interest in my dogs and gave them away. I bought a skidoo, secondhand from one of the boys in town, but it broke down in the spring. It was very frustrating because I did not know anything about skidoos and parts were hard to get. I had to work on the carburetor and it was cold on my hands.

When I first started working in town I still used to trap on the weekends. The price for fox pelts was high a few years back and the money helped buy extra equipment and supplies. Now I hardly trap anymore. I used to be able to skin a white fox while riding on a



sled pulled by a skidoo, but since losing my arm I no longer work on fox pelts. I try, but I have trouble finishing them.

In the hospital I had problems feeding myself with a spoon and I felt that I would be useless. After learning how to use a spoon with my left hand, I started using a knife to cut my food. The nurses were very helpful at first when I was eating. Later I started thinking I had to help myself so I asked the nurses to leave me alone. I had to learn how to help myself.

When I returned home I had to learn many things, driving skidoos, three-wheeled bikes and outboard motors. The first time I tried to skin a caribou, the person I was hunting with finished three before I finished one. Later on I learned how to set traps with one hand. I still trap a little, but only with four traps and short distances.

When I went back to work, I became a cashier. I told the manager I still wanted to drive a truck. He said, "How are you going to drive with only one arm?" I told him, "I still have my brains and the only thing that is missing is my arm." He smiled and told me to go ahead and try. That same day I was driving again, and later on I learned again how to use all the equipment I used to operate, even the D-8 bulldozer.

I am still working and supporting my family, though today the children eat mostly store-bought food. Some things are still hard for me to do, but I refuse help, because someday I may be out on the land alone and have only myself to rely on. I would also like to mention to everyone to be very careful when working around machines.

*Joe Ashevak and Lloyd Jones  
Spence Bay 1984*

# Making Waterproof Kamiks

Made by Seepola Nowdluk, Frobisher Bay, 1984

Text by Melanie Hadlereena, Attima Hadlari and Maureen Jensen

Photographed by David Poisey

There are several kinds of kamiks, all employing different materials and techniques. The warmest kind are made of caribou and used in winter, especially when undertaking long trips. The skin from the legs of caribou is used for the upper or leg portion of the kamik. The hair, which is left on, helps shed snow. The foot portion, when made from caribou, also has the hair left on, but is reversed so the hair is on the inside.

There are two kinds of sealskin kamiks. One is waterproof and used during the spring and summer. This kind is the most difficult to make, mainly because of the stitching. The sealskin which is used must have all the hair scraped off.

The other kind of sealskin kamik is fancier. It uses sealskin with the hair left on, usually with designs worked into it, for the upper or leg portion. These kamiks are not waterproof and are not as warm as caribou kamiks.

For light use, kamiks are sometimes made with canvas for the upper part and sealskin for the foot.

The general design of kamiks is somewhat different from the winter footwear used by Indians. Kamiks must fit more snugly at the ankle, since thongs are not used to hold them in place. The uppers tend to be more capacious, in order to allow bulky windpants to be tucked in.

The kamiks described in this section are the waterproof kind. The length of time to make them varies. All the pieces must be chewed before they can be sewn, and this in itself may take as much as two days. Sewing may take several more days. Seepola Nowdluk, who made the kamiks shown here, is considered one of the best kamik-makers in her community, and one of the fastest. She can make a pair of kamiks in two days.

People interested in making kamiks of this kind, but who have not done so before, will need the assistance of an experienced person. The following section should be considered only an outline or introduction to the demanding skills of kamik-making.



Elisabeth Hadlari

Waterproof kamiks.



Elisabeth Hadlari

Fancy kamiks. The ones worn by men (left) are taller and have a design on the front of the leg. The ones worn by women (right) are shorter and have a design which goes completely around the leg.



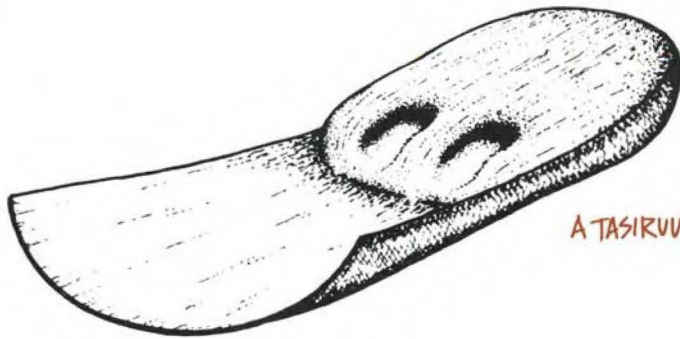

A TASIRVUT, OR HOMEMADE TOOL FOR STRETCHING SKINS



THIS STYLE OF ULU IS USED TO CUT DRY SEALSKIN

### Materials Used

#### sealskin (ringed seal)

- approximately 55 cm x 90 cm, hair scraped off and skin dried to make four pieces (a leg piece and top of foot for both kamiks)
- two strips with the hair left on, about 5 cm x 52 cm each, for the top of both kamiks

#### sealskin (bearded seal)

- approximately 40 cm x 50 cm, hair scraped off and skin dried, to make 2 soles

#### caribou sinew (from back of caribou)

- to sew the pieces together

#### fabric

- two pieces about 9 cm x 57 cm to form a collar at the top of the kamiks

#### woollen yarn

- two braided strings about 170 cm long each

### Tools Used

- ulu (woman's knife)
- tasirvut (stretching tool)
- square or glover's needle
- thimble
- scissors
- stretching stick

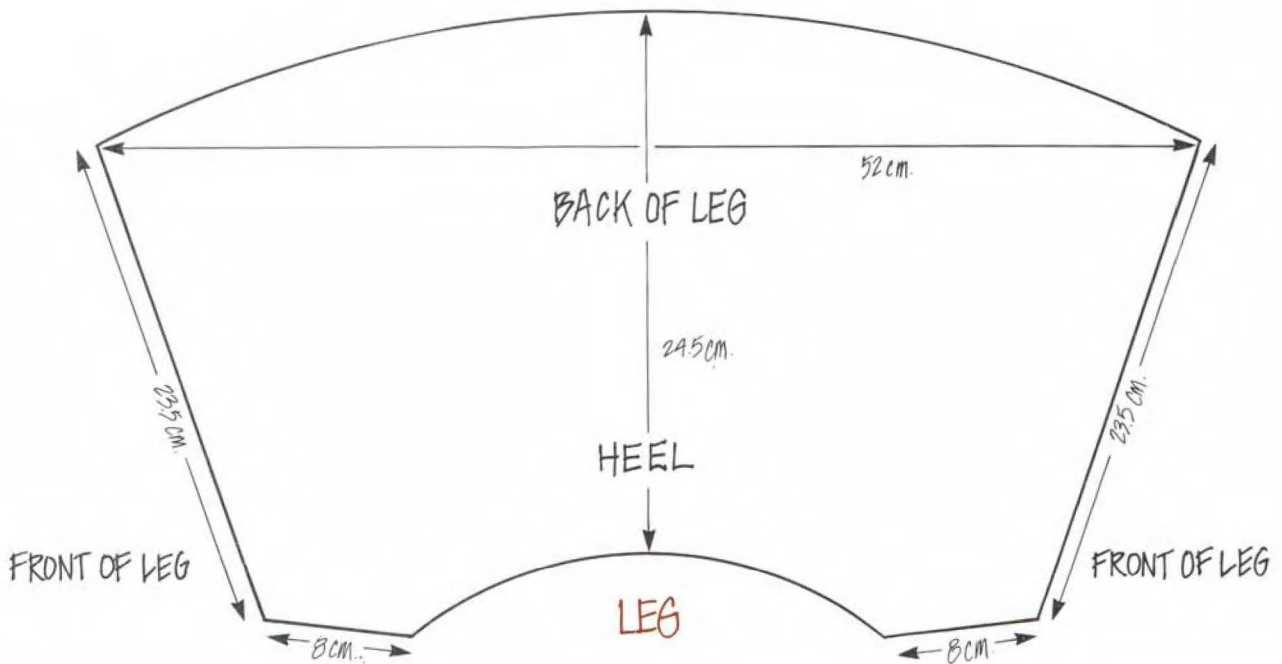
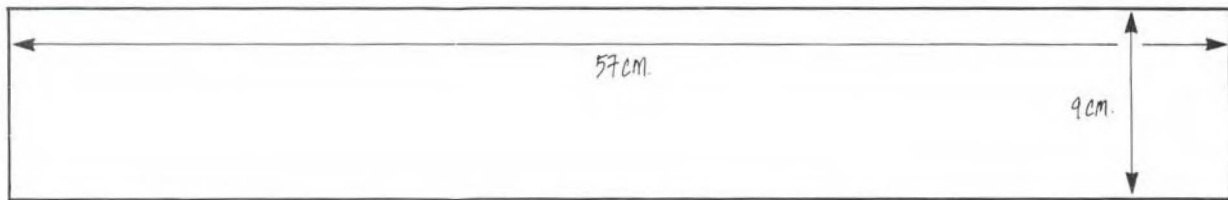
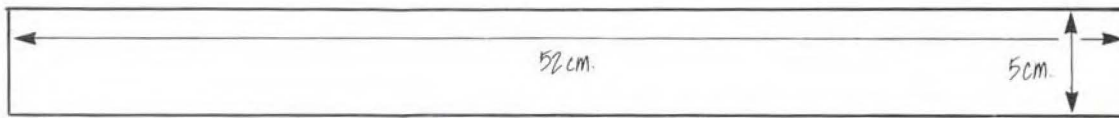
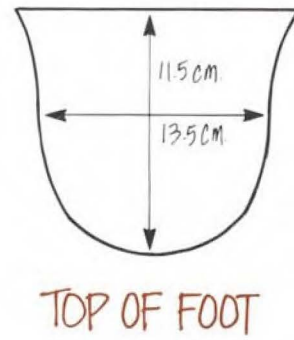
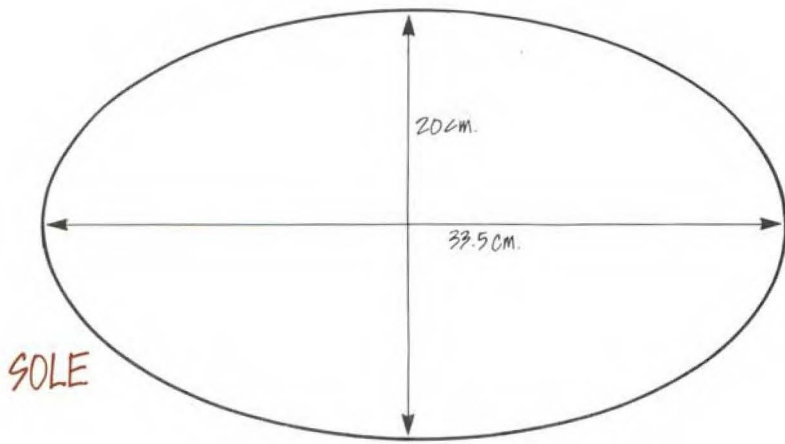



## A. Cutting and Chewing the Pieces

- 1 Seepola cut out the different pieces using an ulu and following patterns made of paper or cardboard. The grid provided shows the size and shape of the pieces used. These dimensions will change depending on the foot size of the person for whom the kamiks are being made. When measuring footsize, don't forget to leave room for duffles. The kamiks made by Seepola were approximately a ladies' size 6.
- 2 Seepola used only half of the pattern shown for the leg. (1) She folded the sealskin (ringed seal) in half and scratched the outline of the pattern onto the skin. This ensured that, when the doubled skin was cut through, the piece was perfectly symmetrical. Since scraped and dried sealskin is so hard and tough, it cannot be cut quickly. Notice the stiffness of the skin, and how the ulu is held. (2)
- 3 The leg pieces have to be thoroughly chewed to soften the skin. Chewing is an important part of kamik-making. As much as two days may be needed to chew all the pieces before they are sewn together. Without chewing, the skin would not be flexible enough to wear, and a sewing needle would not be able to penetrate it. (3-5)



4 Seepola cut out the pieces for the top of the foot, then folded them lengthwise to make sure they were symmetrical. (6) She scratched a sewing line around the margin of each piece, about 4 mm from the edge. This line helped to keep the stitches straight. (7) The pieces were then chewed. (8)

5 Bearded seal was used for the soles rather than ringed seal because it is thicker and more durable. Like the other two pieces, the sole was chewed thoroughly on both sides. (9-11) In addition, seal fat was rubbed into the top and bottom of the sole. Like chewing, this softened the skin and made it easier to sew. (12)

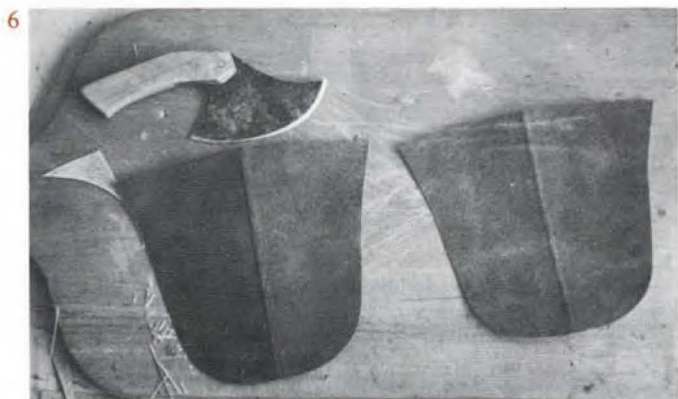



6 Seepola used a homemade tool, shaped like a shoehorn, to further work and stretch the leg pieces and the soles. Here, a piece was draped over the edge of a chair and the tool forced downward against it. (13) Seepola also used the tool while seated on the floor. (14) Both sides were worked.

7 Stretching increased the size of the pieces, so they had to be trimmed back to the original size. (15,16)



## B. Sewing the Leg and Foot

1 The leg piece was folded (17) and sewn together to form a vertical seam at the front of the kamik. (18,19) A small flap of no more than 5 mm was left free.

(Seepola often used a towel with a piece of sinew attached to the part of the kamik she was working on. Holding the towel between her knees and keeping tension on it allowed her to sew with greater ease and precision.)

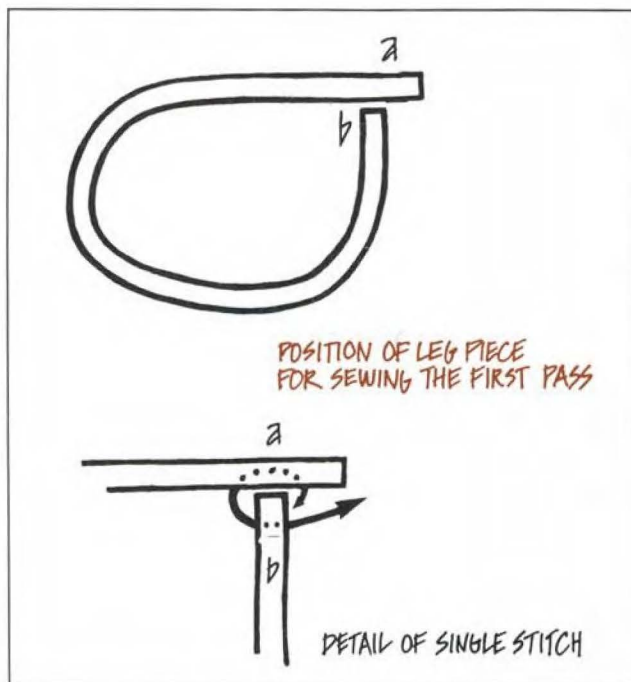

Care must be taken not to pierce the skin completely through a point *a*, as this would destroy the waterproof quality of the skin. The stitches at point *b* penetrate both sides of the skin; they are made as close as possible to the edge of the skin.

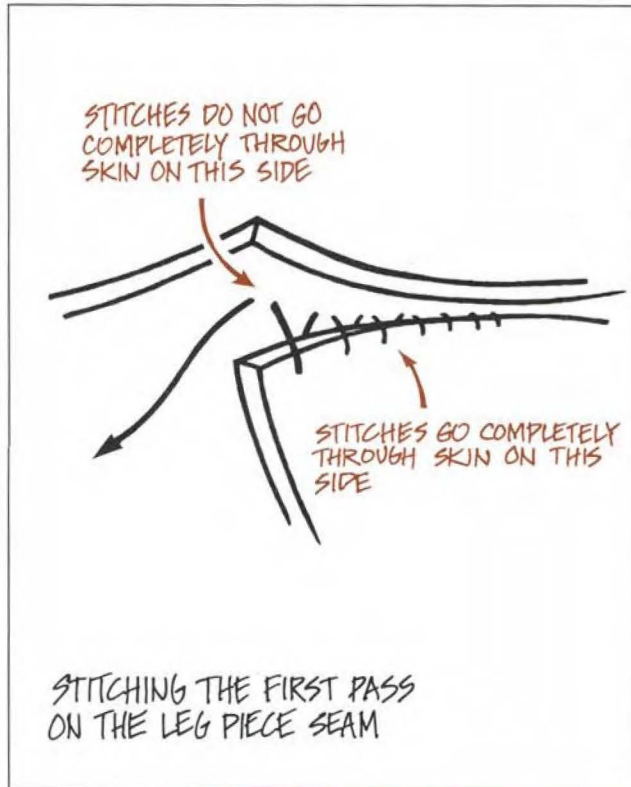



- 2 After the first pass was stitched, the flap was folded over and stitched again. This was the second pass, and formed a raised or welted seam. (20)  
 The stitches did not go completely through the skin at either *c* or *d*.

20



21

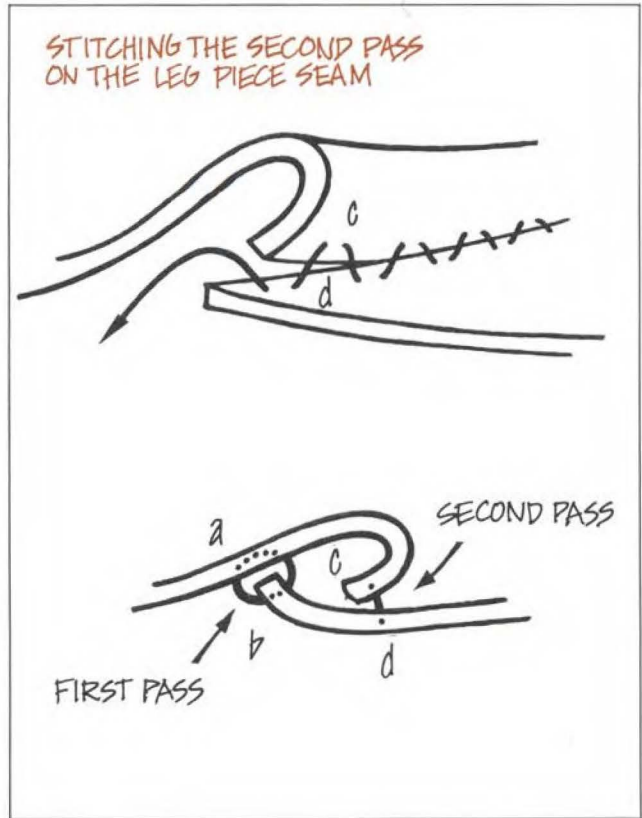
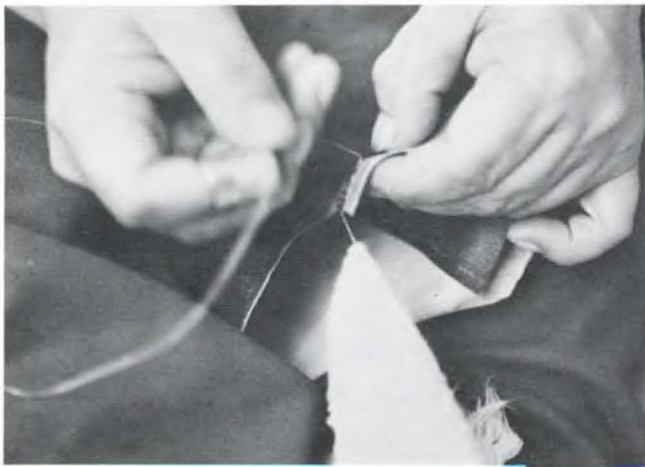

22



- 3 The piece for the top of the foot was attached to the leg piece using the same sewing technique and resulting in the same welted seam. (21,22)
- 4 The pieces had to be chewed periodically to keep them pliable. (23)

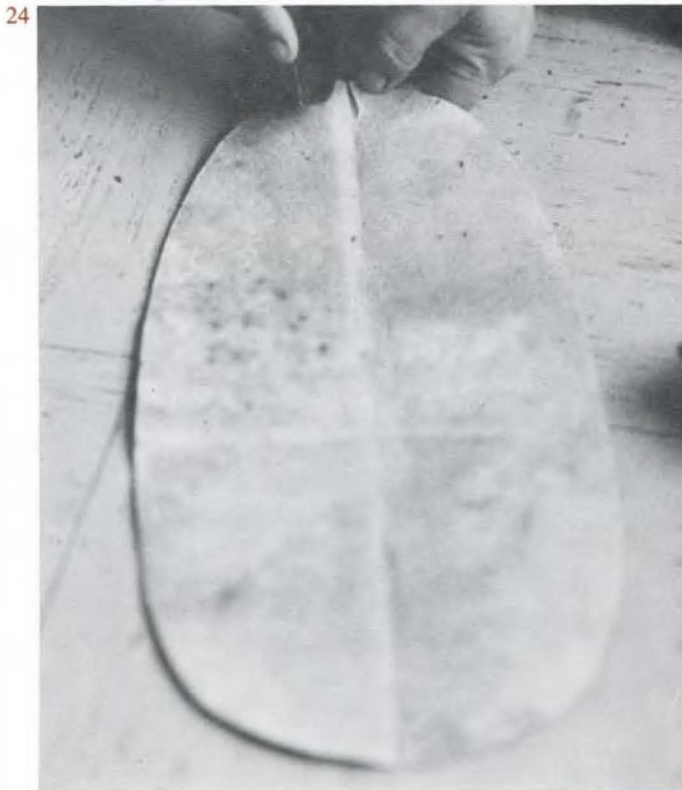

## C. Attaching the Sole

- 1 Before the soles were sewn on, they were notched on the inside in four places — at the centre of the toe and heel, and midway on each side. (24) These marks were lined up with points on the other pieces to make sure the sole was sewn on properly. The toe notch lined up with the fold mark at the tip of the piece covering the top of the foot. The heel notch lined up with the fold mark at the bottom back of the leg piece. The two side notches lined up with the end of the welted seam joining the leg piece and the top-of-the-foot piece.
- 2 Seepola scratched a line along the bottom of the leg piece, about 4 mm from the edge, so that it matched with the line scratched along the margin of the piece covering the top of the foot. (25) The soles were then sewn on, with the stitching of the first pass following this line. (26-29) It was necessary to make a tiny gather for each stitch in order to marry perfectly the sole to the rest of the kamik.





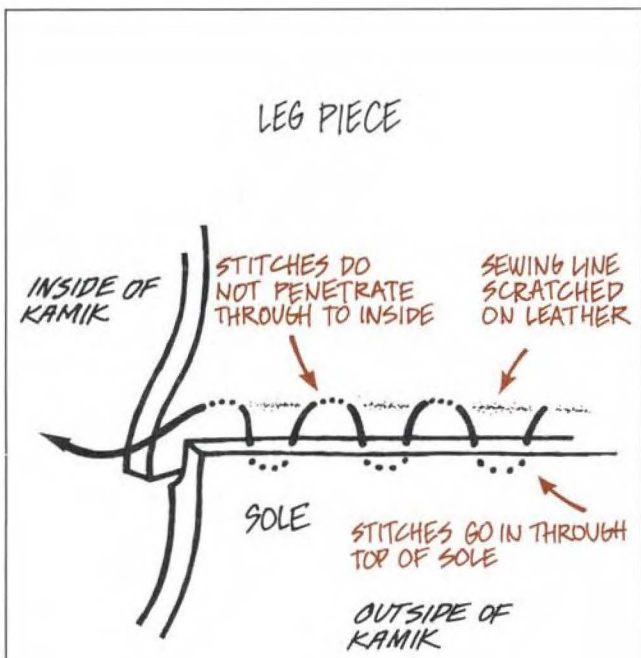

The sole, which was of bearded seal, was noticeably thicker than the other pieces. The stitches went in and out through the top of the edge. The stitches in the leg piece did not go all the way through the leather. This was the first pass in sewing the sole.

- 3 The kamik after the sole had been attached by the first pass. (30) Notice the bulky heel. This was corrected in step 6.
- 4 Seepola then turned the kamiks inside out and used the ulu to thin the very edge of the sole. (31)
- 5 The second pass was then sewn. (32) The stitches this time were not so fine as those used in the first pass on the outside. The stitches went completely through the bottom of the leg piece *a* but not completely through the sole *b*

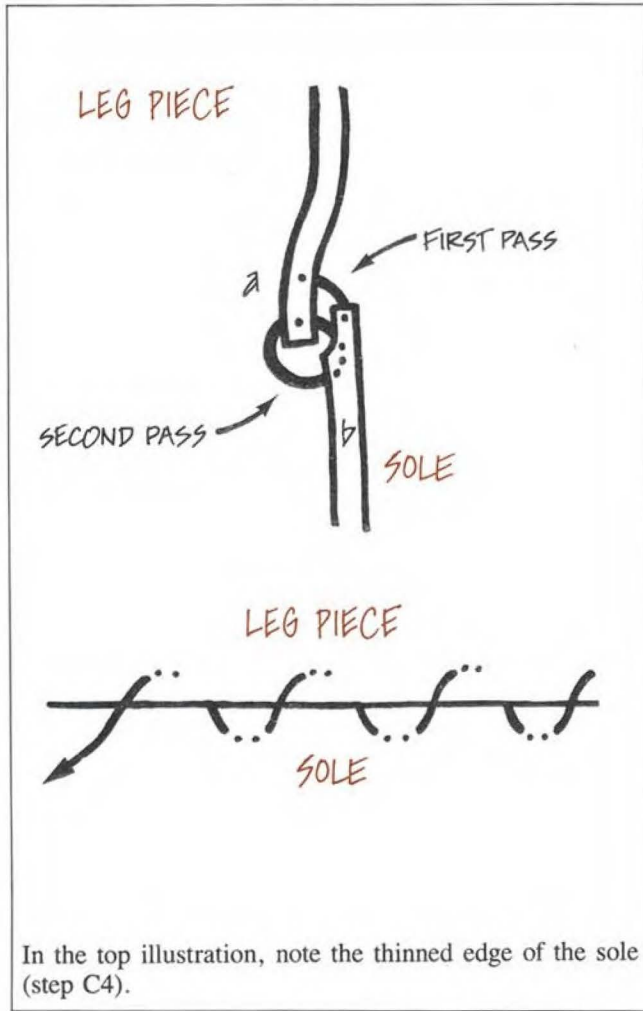
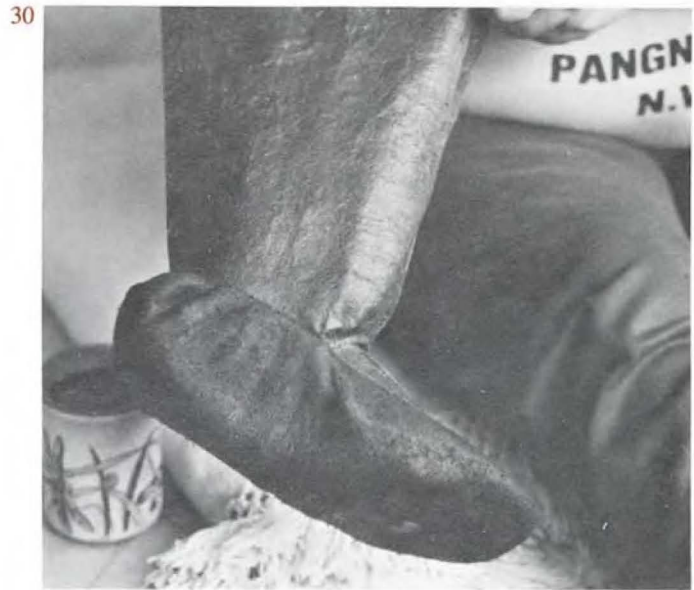



- 6 While the kamiks were still inside out, two lengths of sinew were sewn into the heel — again, taking care not to penetrate the outer surface of the sole. The sole was bunched or gathered around the sinew to strengthen the heel and make it fit better. (33) The second strand was sewn into the heel about halfway between the first one and the bottom of the sole.



## D. Finishing the Kamik

- 1 The kamiks with the inside stitching completed and turned right side out again. Notice the shape of the heel. (34)
- 2 A strip of ringed seal with the hair on was then sewn to the top of the kamik. This was mainly for decoration. The stitches were not waterproof. (35,36)
- 3 A strip of fabric was folded along its length and sewn to the top of the kamik. (37)



37



4 A braided length of yarn was inserted through slits at the rear of the fabric collar. (38)

38



5 The kamiks were chewed one last time (39), worked over the end of a stick (40) and then deemed ready to wear. (41)



Position of woollen drawstring within fabric sleeve.

39





40



41



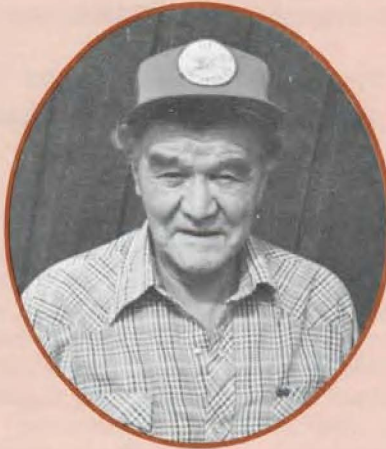

## Daniel Sonfrere

Daniel Sonfrere was born in 1918 in the old village of Hay River. As a boy, there was no time for school because he was in town only from June to August. During the rest of the year he was with his family out in the bush. His mother died during an influenza epidemic when he was ten. A few years later, his father shifted his trapping area from Tathlina Lake and Cameron Hills to Wood Buffalo National Park. Together they built a cabin at the north end of Buffalo Lake near the source of Big Buffalo River.

There they hunted moose and caught their winter supply of fish from the large annual run of inconnu migrating from Great Slave Lake. In the winter they trapped lynx, fox, marten, and mink, mainly to the east. During the spring hunt, beaver was their main quarry.

The north end of Buffalo Lake was a focal point for all the families that camped in the vicinity. In early August, those people and their dogs, loaded with winter supplies, would arrive there on foot from Hay River. Then again at the end of May everyone would converge at the Sonfrere camp. It was a time of celebration following a winter of hard work. Some of the younger men would be selected to lead all of the sled dogs back to Hay River through the bush, while most of the others drifted down the river, leisurely hunting moose and beaver, before paddling along the shore of Great Slave Lake to Hay River. Daniel remembers leading over 100 dogs for about 36 hours, non-stop, to town. Because the dogs always fought, it was impossible for anyone to sleep along the way.

Daniel tells about one spring when he and some others almost stayed out hunting too long. At the end of March, they headed south from Buffalo Lake into country where break-up occurs earlier than where they usually hunted. One day, far into the Caribou Mountains, Daniel and one of his elder companions met four

strangers on a lake — Cree people from farther south. Their tall stature was a little intimidating to young Daniel. Also, there was a language barrier. One of the Crees spoke a few words of English and although Daniel spoke very little English at the time, he had to act as translator for his companion. Perhaps his hunger for flour (which they had been without for some time) sharpened his understanding, for he was able to make out that the Crees had some to spare. They visited for a few hours, and after they departed Daniel never saw them again. Although it was beautiful country abounding with moose, woodland caribou, beaver, and waterfowl, the leaves were out on the trees, indicating that Daniel and his companions had to head north soon to join their people at Buffalo Lake, or be left behind. At the headwaters of Whitesand River they built a canoe and drifted down to the camp at the west end of the lake from where they had begun their journey in March. It was now early June and their families, having waited as long as they could, were all geared up to begin paddling for Hay River the very next day.

Daniel got married when he was 24 and had two boys. One died and later another was adopted. In 1978 Daniel's wife died. Throughout the years he has always kept the same trapping area near Buffalo Lake and around eight to ten years ago he switched from a dogteam to a snowmobile. For several years he has been the group leader of the Hay River trappers in Wood Buffalo National Park.

Although beaver prices are currently quite low, he still likes to go out to Buffalo Lake each spring. There is always a lot of work around the camp, like putting away winter gear, repairing the cabin, cutting wood, and hunting for fresh meat.

*Tom Chowns  
Hay River 1983*



# Making a Spruce Bark Canoe

Made by Johnny Klondike, Fort Liard, 1983  
Text and photographs by Barbara Winter

Birchbark canoes are often thought of as the traditional "Indian canoe" in Canada. While they were widely used, small canoes made from a single sheet of spruce bark were also widespread. In the Northwest Territories, the Dogrib, Mountain, and Slavey tribes used them. Temporary spruce bark canoes were used to traverse lakes and rivers, and to gain access to remote hunting areas. Being small, they were easily portaged and carried into the mountains.

Spruce bark canoes are made more easily than birchbark canoes. The covering of a birchbark canoe must be pieced together from many small sections of bark, while spruce bark canoes are made from a single sheet. The spruce bark canoe therefore takes less construction time and less effort. However, the birchbark canoe is much more durable, and therefore lasts longer.

Spruce bark canoes can only be made in the spring, in late May and early June when the sap is rising. The bark can easily be peeled from the tree at this time. At other times of the year it adheres closely to the underlying

wood and cannot be pried off the trunk without damage.

The following is a description of how Johnny Klondike of Fort Liard made a spruce bark canoe in June of 1983. It took him four days to do it. He said that when he was younger he could build a canoe in two days, taking the first day to gather the materials, and the second to assemble the canoe.

The canoe he made could carry one or two people, and would have been used in hunting. Although usually made for immediate use and then discarded, a well-made and cared for spruce bark canoe will last up to five years under normal use. It should be stored upside down in a shady spot, elevated off the ground. It should be protected from the sun, which dries it out and makes it crack, and protected from the snow. A heavy snow load will place unnecessary strain on the canoe.

The canoe which Johnny made is now part of the collection of the Prince of Wales Northern Heritage Centre in Yellowknife.

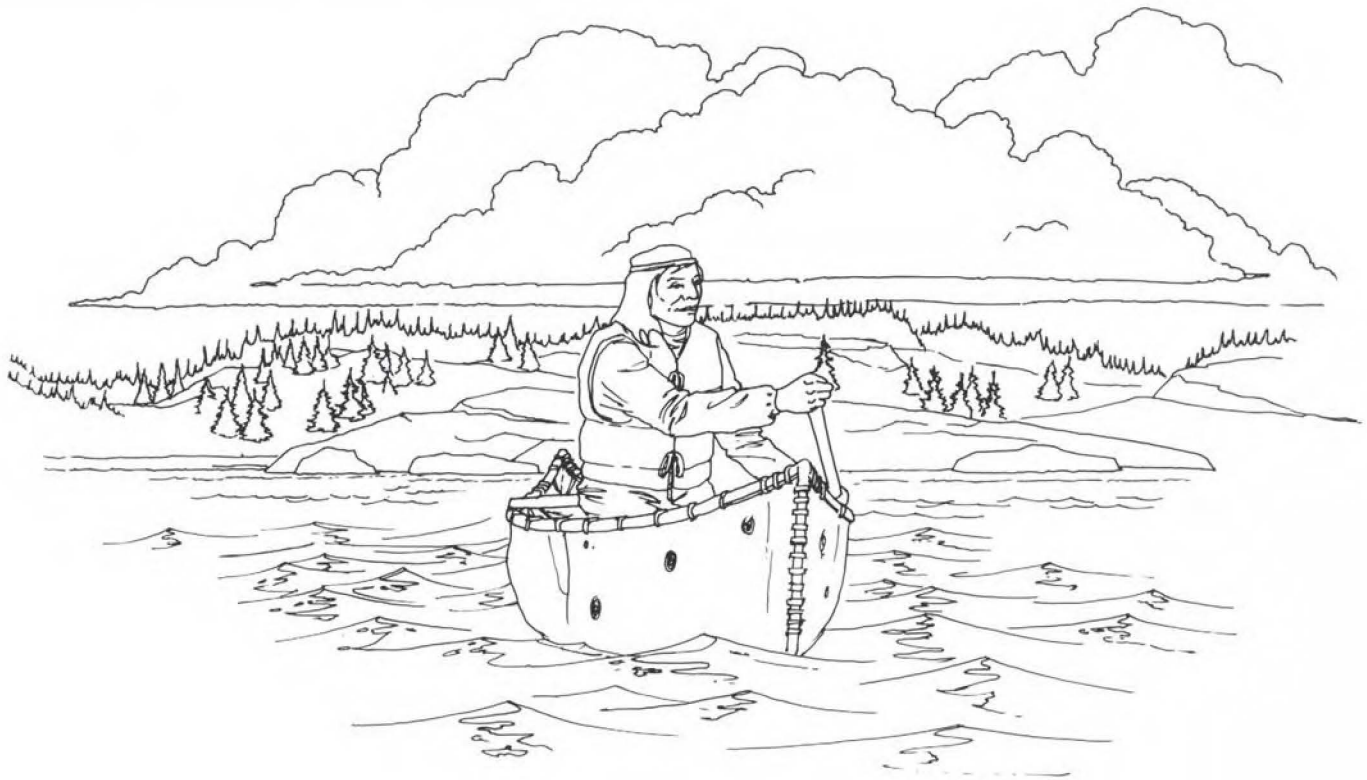

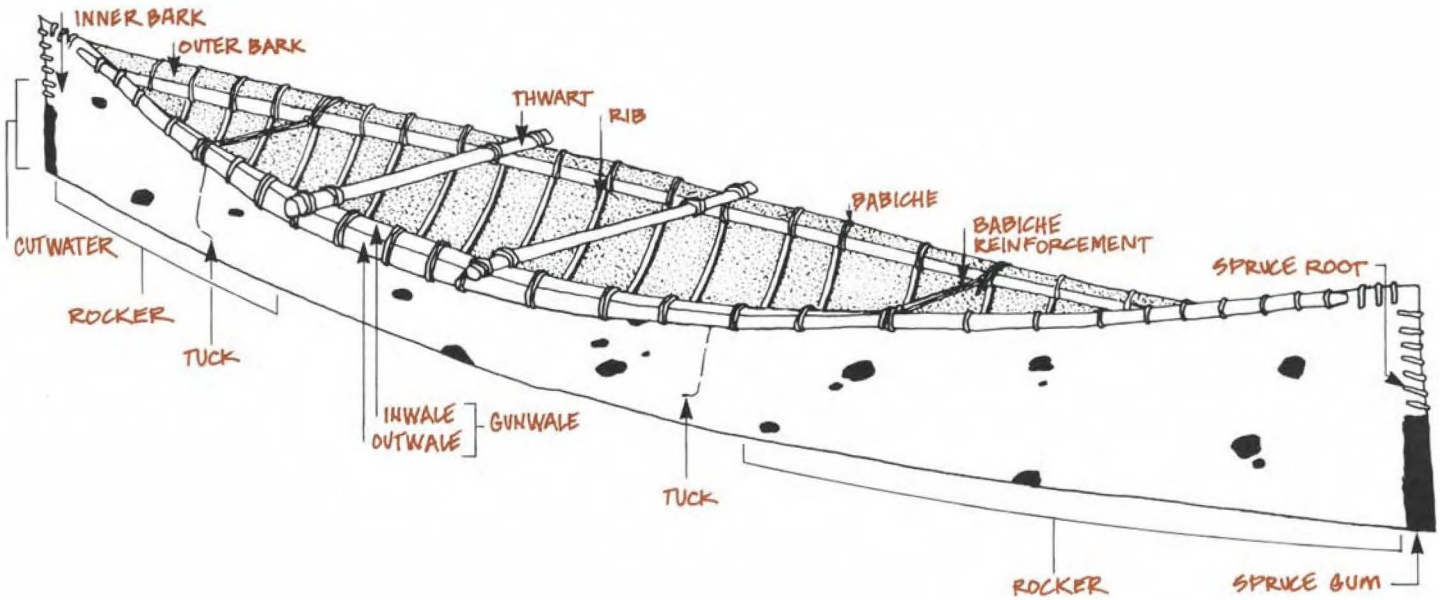

**Materials Used**

- single sheet of white spruce bark, at least 1 x 4.2 m
- 30 diamond willow sticks (ribs) 1-1.7 m long
- 20 stakes, 60 cm long
- 4 black spruce trees (gunwales) over 5 m high
- 2 sticks (spreaders) 35 cm long
- spruce root, more than 3 m
- spruce gum, more than 0.5 kg
- babiche, more than 15 m
- birchbark scraps (torch), at least 20 pieces 15 cm square
- logs and brush (sawhorses)
- 2 logs (weights)
- leaves (bow and stern props)

**Tools Used**

- axe
- crooked knife
- awl
- chain saw
- homemade spud



## A. Making the Gunwales

1 The gunwale on each side of the canoe is composed of two pieces of wood, the inwale and the outwale. Four small black spruce trees were selected to make them. These trees had to be straight and green. Suitable trees grow in muskeg, and are no more than 5 m in height. They are 7-10 cm in diameter at the butt, and 3 at the tip. The trees must be flexible and springy, not "too hard" as they must bend to form the gunwales. Johnny checked for straightness of grain by shaving a small section of bark from the tree while it was standing. If the grain was straight, the tree was cut and limbed.

The top section of the tree was used. Johnny measured "two-and-a-half arm's lengths" (3.5 m) for the inwales and "three arm's lengths" (4 m) for the outwales, and cut the butts off. Johnny said that if the gunwales were too long the canoe would be weak. (1)

2 The bark was then removed from all four trees. Each butt was trimmed so that both ends of the tree tapered uniformly. (2) The inwales were formed by shaving the inner surface flat at both ends. They made a flat V when joined together at each end. To hold them, they were notched and lashed together with babiche. (3,4)

3 To spread the inwales, Johnny cut a stick 35 cm long and notched the ends. He forced it between the middle of the inwales (5) and placed the structure on a slight slope so that the middle was suspended. A tree was cut and placed across the middle of the inwales. This weight caused the inwales to bend slightly, raising the bow and stern. (6)

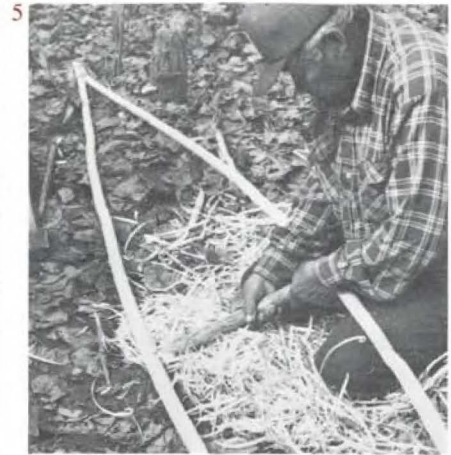
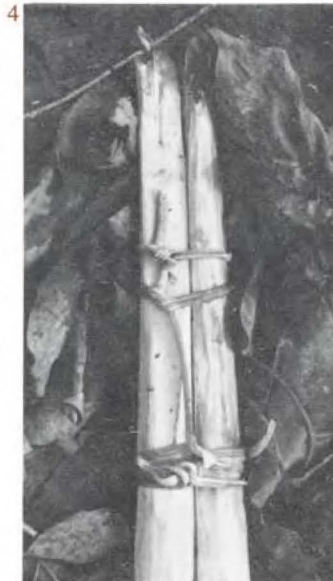



## B. Gathering the Ribs, Roots and Gum

- 1 Johnny cut 30 diamond willow sticks for ribs. They were unbranched, 1 to 2.5 cm in diameter, and over a metre long. Johnny used up to 90 cm of this length. He trimmed the leaves and tip from the sticks, and shaved the butt flat on one side. He bent each stick around his knee, slowly forcing it into a U shape. (7) The ribs were then set aside until needed.
- 2 Johnny cut 20 stakes, each approximately 60 cm long and about 3-4 cm in diameter. He sharpened one end with his axe, and carefully smoothed one side. The stakes were used to support the bark and form the hull shape. (8)
- 3 Johnny looked for a fallen, very rotten log under the moss, and dug the root out with his hands. The root had to be straight, unbranched, and not more than a centimetre in diameter. He coiled each root for later processing. Back at camp he boiled the roots to loosen the outer layer, then stripped it off. The roots were split in two lengthwise. Care was taken to split them evenly.
- 4 Johnny collected the spruce gum that would pitch the bow, stern, and hull. He looked for large wads of gum that were not too dry. (9)





## C. Barking the Tree

1 Johnny searched for a good tree to provide the bark. The tree had to be a white spruce, and not have any low branches. Johnny estimated the size by hugging the tree. If he could just touch his fingers around the trunk, it was large enough.

Johnny then measured the trunk again by wrapping a pliable willow branch around the tree. He removed it and placed it in a U position on the ground, estimating the size and shape of the finished canoe. (10,11)

If the tree was large enough Johnny tested the pliability of the bark by chopping a rectangular section from the trunk, quite close to the ground. This section was about 10 by 20 cm. He twisted and folded the bark, rough side in. If it split, the bark was not pliable enough and the tree could not be used. He also checked that the bark was thick enough. The bark he used was approximately 6 mm thick. (12)

2 The tree was cut down before the bark was removed. First Johnny cleared the small bushes and log debris from the work area. He then prepared two

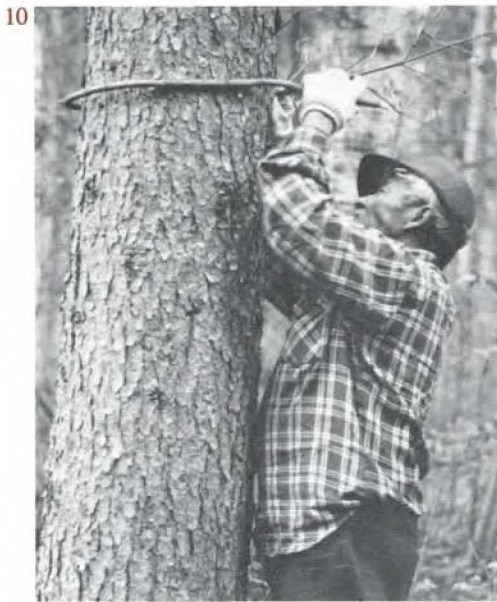

“sawhorses” onto which the tree was dropped. The felled tree had to be elevated to allow room for the bark to be removed.

A “sawhorse” was made by placing two logs parallel to each other on the ground, about a metre apart. They were covered with brush, and a live tree cut and put on top of the brush, parallel to the dead trees. The “sawhorses” were aligned perpendicular to the line on which the tree was to be felled. One “sawhorse” was put about 2 m from the tree, the other just under 6 m from the first. (13)

The tree was felled with a chain saw. The top of the felled tree, which would not be used, was cut off. The small dead twigs on the lower part of the tree were limbed with an axe. After Johnny cut each twig off, he banged the knot with the butt of the axe head. This compressed the opening and reduced the size of the knot hole in the bark. The bottom of the tree (up to about a metre from the cut) was not used.



3 Johnny marked a point a metre from the bottom of the log as his starting point. It marked one end of the sheet of bark which was to be removed. He then measured a bit more than three arm's lengths (4.2 m) along the tree. This marked the sheet of bark to be removed. Using his axe, Johnny trimmed off the rough scales of outer bark along this line (14), then cut through the bark along the centre of the cleared section, making certain the bark was completely cut through. (15) Johnny used his axe to pry up a lip of bark along the line. (16)

4 Johnny made a spud to pry off the bark. It was cut from a live alder tree which was growing with a slight curve. The curved portion was smoothed and rounded. (17)

Working along the trunk, Johnny pried a section of bark about 12 cm wide off one side of the incised cut with the spud. (18)

The bark was pushed away from the trunk, working slowly and carefully up and down the trunk. Johnny removed a section of bark along the length of the trunk, so that the work progressed evenly along one side of the tree. (19) (If he had pried more in one spot, the bark would have hung unevenly and might have torn.) He was extremely careful not to exert too much pressure on the bark as he pushed it away from the trunk. Particular care was taken around the small knots. As he got more bark loose, Johnny pried a smaller section each time. The initial 12 cm swath was reduced to about 4 cm.

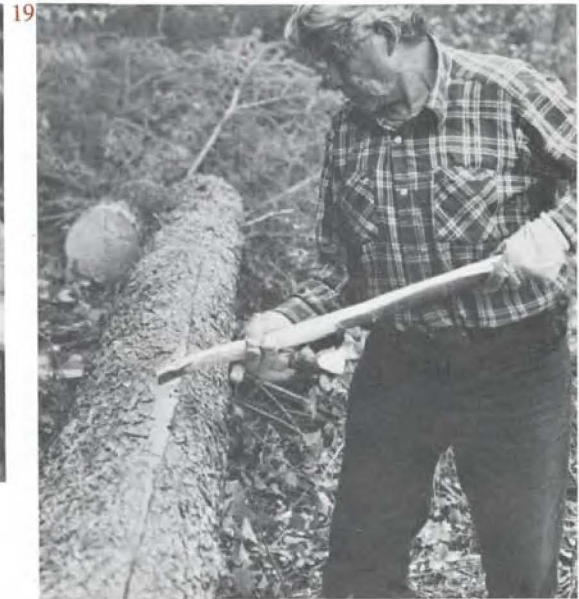
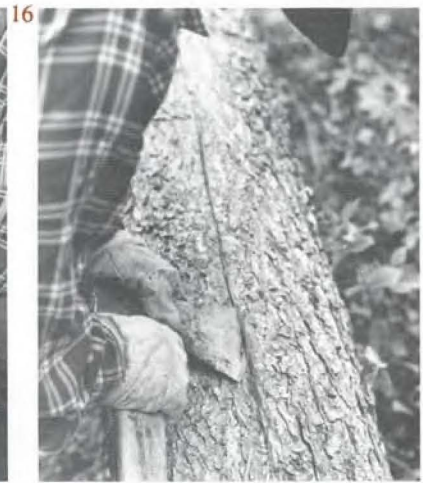
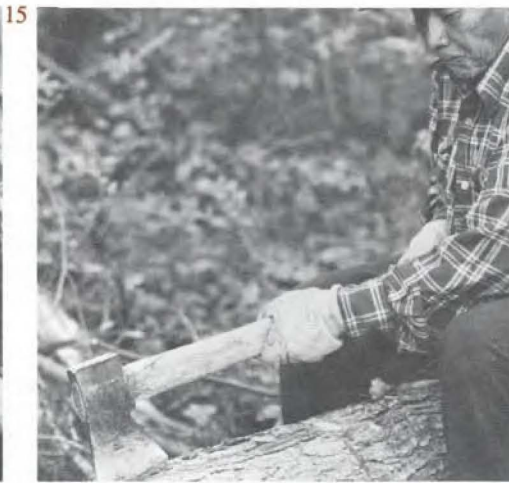



5 After the bark was separated from the trunk on one side, it was returned to its original position (wrapped loosely around the trunk), before work on the second side was begun. (20-22) Several small stakes were used to support the bark at the end of the second side. (If the bark had been allowed to hang, it could have torn as it was removed.) When the bark was completely removed, it was rolled into a bundle,

rough side out, starting from the top of the tree. (23,24)

6 The bark was transported in this fashion back to the area where the canoe was to be constructed. There it was unrolled, the ends being elevated by placing piles of leaves underneath. The inwales, still stretched apart, were placed on the bark and centred. (25)

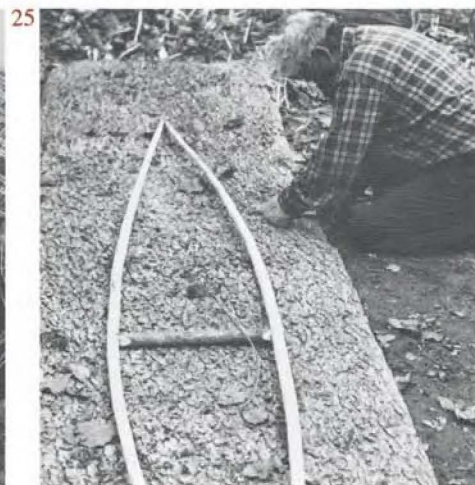

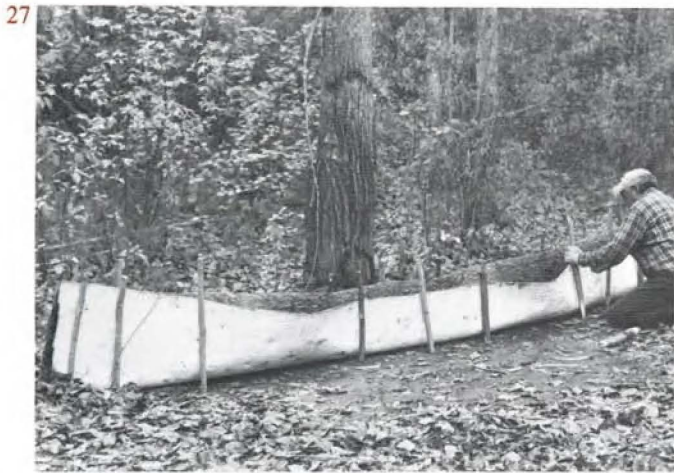

## D. Making the Tucks

- 1 In order to create the rocker at the upswept bow and stern, the bark had to be tucked in four places. To facilitate this, the rough scaly bark was trimmed from the area of each tuck with a crooked knife. The trimmed areas were 22 cm deep by 12 cm wide. A rectangular section at the bow and stern keel were trimmed in the same way — about 10 cm wide and 25 cm long.
- 2 The bark was then bent up around the inwale and held in place by the stakes. (26,27) Stakes were not placed beside the trimmed areas where the tucks would be made. More leaves were placed under the bow and stern to further elevate the ends.
- 3 Johnny then folded and tucked the bark. Each flap was tucked to the inside and toward the centre of the canoe. (28) Additional stakes were pounded into the ground to brace the tucked sections. The outwale was placed inside the row of stakes against the outside of the bark, and the inwale was elevated and held in place with a small stick. Holding the outwale and inwale together, Johnny cut off the bark which protruded above them.

(Father P. Mary, who has lived in Ft. Liard for 25 years, said that in early spruce bark canoes the tucks were cut out and a patch of birchbark placed over the hole. This reduced the unevenness of the canoe's covering, making it less noisy as it was paddled. Without the birchbark patch, the water would eddy around the tuck, making a ripple. This noise would frighten away beaver, muskrat, and other game.)

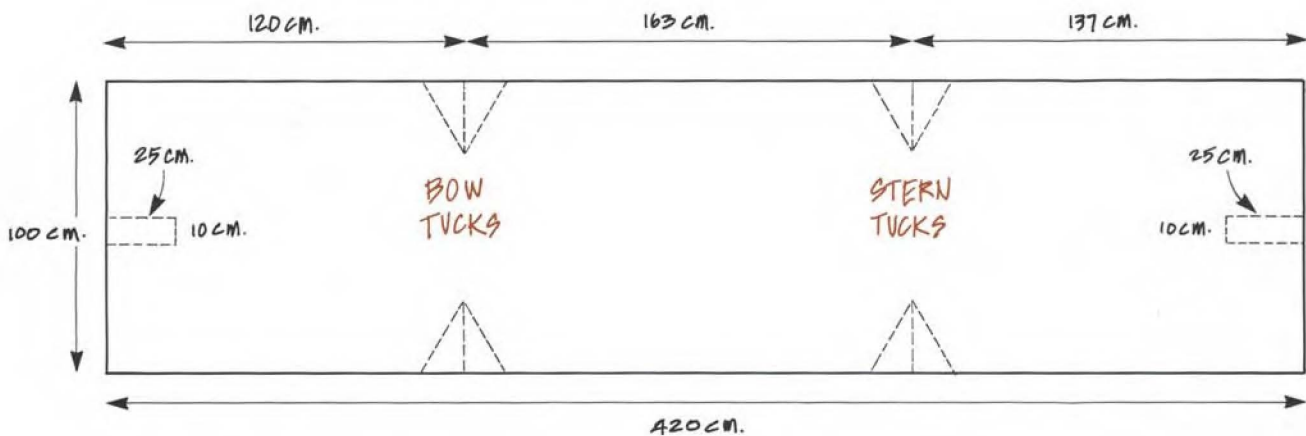



## E. Sewing the Gunwales

- 1 Johnny punched a hole through the bark from the outside on one side of the tuck. Using three loops of babiche, the inwale and outwale were tied in place. The babiche was then brought along the outwale to the other side of the tuck, where the process was repeated. (29,30) Each of the four tucks was fastened in this way.

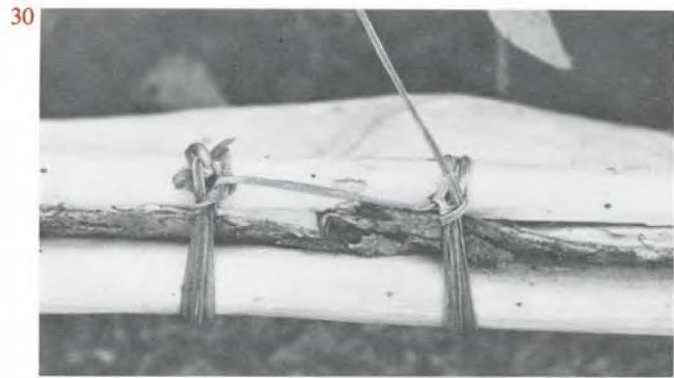
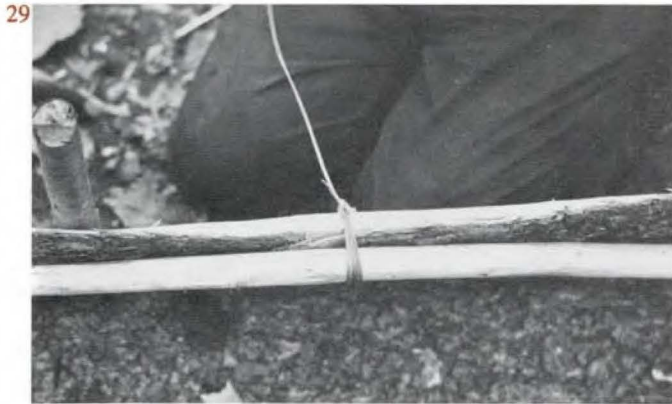

- 2 The remainder of the bark was tied to the gunwales in sections. First Johnny tied the section from the bow tuck to the bow, then from the stern tuck to the stern, on the same side. (31,32) The other side was then tied. These end sections were tied quite closely together (10-12 cm apart). (33) Next the centre section on each side was tied. As this section took less strain, the knots could be placed further apart (12-18 cm). Here each knot was tied separately. The centre section was tied in four parts, first from the centre to the bow tuck then from the centre to the stern tuck, both on the same side. This was repeated on the other side. Johnny removed the stakes supporting the sides of the canoe as he worked, as they tended to get in his way.

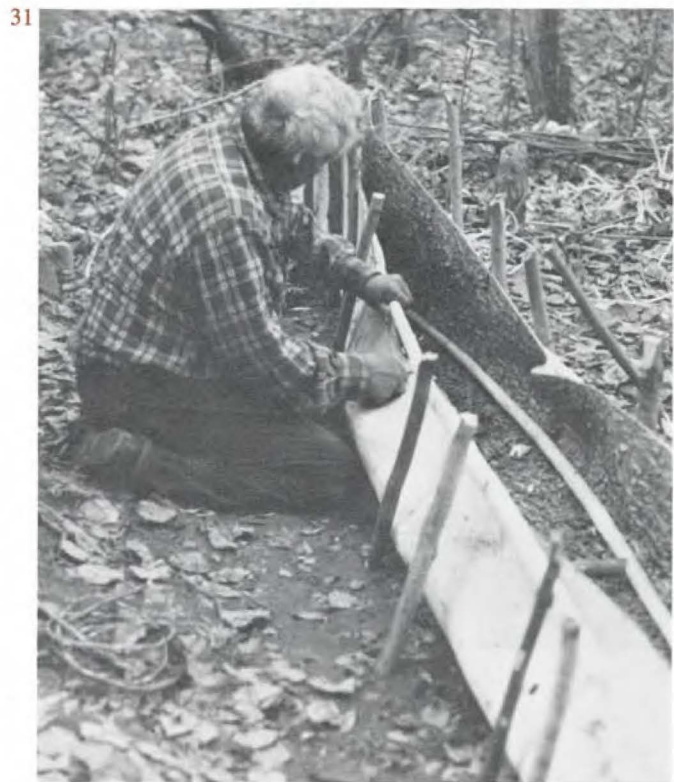



## F. Fitting the Ribs

- 1 To prepare for fitting the ribs, Johnny cut spreaders and placed them across the inside of the gunwales. The bow and stern spreaders were about 40 cm long, the centre spreader about 45 cm long. They were about 4 cm in diameter. Each end was notched to hold the gunwale. They spread the gunwales apart, holding the shape of the canoe until the ribs were inserted. After the ribs were in place, the spreaders were removed.

Johnny then put a log across the gunwales at each tuck. These logs kept the ribs from springing back by maintaining tension on them. (34)



- 2 To fit the ribs, Johnny first knelt beside the canoe facing the centre. He fitted the butt of the trimmed and bent willow rib under the inwale and forced the rib down against the bark, along the side of the canoe. He pushed it into the rounded bottom and down toward the keel line. (35) He held it in place with his knee as he measured it against the opposite inwale. (36) He then bent it toward the centre of the canoe, cut it and forced the end under the inwale against the bark. (37) The end was cut and trimmed flat with a crooked knife. It was a very tight fit. The butt end of each rib was placed alternately against the port or starboard inwale. (38) This maintained an even tension throughout the canoe. The ribs were flattened side up.

Johnny began in the centre of the canoe and worked toward the bow tuck. He next did the stern half of the centre section. Five ribs were placed between the bow and the bow tuck, 16 ribs between the bow tuck and the stern tuck, and five between the stern tuck and the stern.





## G. Making the Thwarts

1 Two of the stakes used to hold the bark were made into thwarts. They were each trimmed flat on two sides and the bark removed. They were cut to extend across the width of the canoe, measured from outer gunwale to outer gunwale. The ends were notched, and they were tied to the gunwale with babiche. Two holes were pierced through the bark below the

gunwale, and the thwart was tied to the gunwales. (39,40)

2 Additional reinforcements were made at the bow and stern. A length of babiche was strung across the gunwales through holes pierced in the bark. Two tight loops of babiche were wrapped around the gunwales, and across the canoe, and drawn taut. (41)



## H. Closing the Bow and Stern

1 To work on the ends of the canoe, Johnny turned it upside down and balanced it on a single homemade sawhorse (a log fastened horizontally between two trees). Then he made a clamp from two stakes. He flattened and smoothed the stakes on the inside, then tied them together at one end. Next he made a crude torch by skewering on a stake several pieces of birchbark from a rotten log.

He lit the birchbark and thrust it inside the bow to warm the spruce bark. Since the dry birchbark burned very quickly and gave a hot flame, the torch had to be moved quickly so that no section of the bow was scorched. With his other hand, Johnny pressed down on the keel to increase the curve of the rocker, and to gauge the heat of the bark. (42)

In less than a minute the bark was warm enough to be squeezed shut at the bow without cracking. The homemade clamp was then applied to the bow as shown. (43) If the bark was warm enough, it closed without stress or cracking within half-a-minute. The clamp was tied shut at the gunwales.

The same process was repeated at the stern.



2 A rectangular section was cut from the bark protruding forward from the bow clamp. Johnny incised a line parallel to the clamp, leaving a 5 cm strip. He incised another line at a right angle to the first, parallel to the keel. The incised lines were deepened until the bark was cut through. Johnny carefully bent the bark and broke it off. With this removed, a short tongue of bark remained at the keel. It was about 5

cm wide and 10-15 cm long. (44) Next Johnny trimmed off the rough scales of outer bark from the section of bark which protruded from the clamp. He paid particular attention to the tongue, from which he peeled off all the dark outer layer, leaving only the flexible white inner bark. This was later bent up and covered with pitch, sealing the cutwater (step H5).

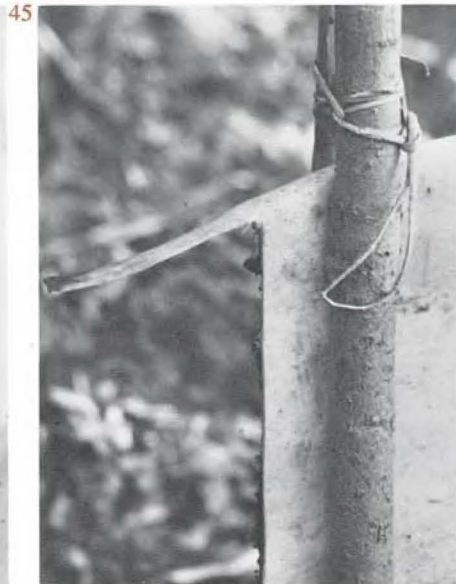



3 Johnny reinforced the bow cutwater with a small stick. He took a willow rod that had been left over from making the ribs, skinned it and shaved it flat on two opposite sides. This was inserted in the cleft between the folded bark protruding from the clamp. It strengthened the bark and provided a base for sewing up the cutwater. (The stick is just visible in photo 45.)

4 Using the spruce root collected in step B3, Johnny sewed up the bow and stern, first punching a hole through both layers of bark with an awl, then threading the root through the hole. The root was sewn with the flat split side against the bark, and the round skinned surface out. The ends of the root were not tied, but secured under a stitch. Johnny threaded each hole, brought the root around the cutwater, then pushed it through the next hole.

(Spruce root was used rather than babiche because spruce root swells when it gets wet. Used underwater, it expands and plugs the holes it passes through, making a natural seal. On the other hand, babiche stretches when it gets wet. As these canoes are usually used on quiet flat rivers, lakes and marshes, the gunwales would not often get wet, but would be exposed to the summer sun, which would shrink the babiche and make it hard. This would tighten the knots and add structural strength to the canoe.)

5 The next day Johnny plugged the holes in the bark with spruce gum. A generous layer of gum was put on the lower section of the cutwater at both bow and stern, and in any small holes elsewhere in the hull. (46,47)

The gum was heated with a small amount of water and chewed. Johnny made another torch and warmed the bark, chewing the gum at the same time. When the bark was warm, the gum was applied quickly to the bark. Johnny took a thin flat stick and spread the gum, melting it into the hole at the same time. This formed a water-tight seal. He used a birch bark tray to catch the dripping gum. (48) With all the seams and holes plugged, the canoe was finished. (49)

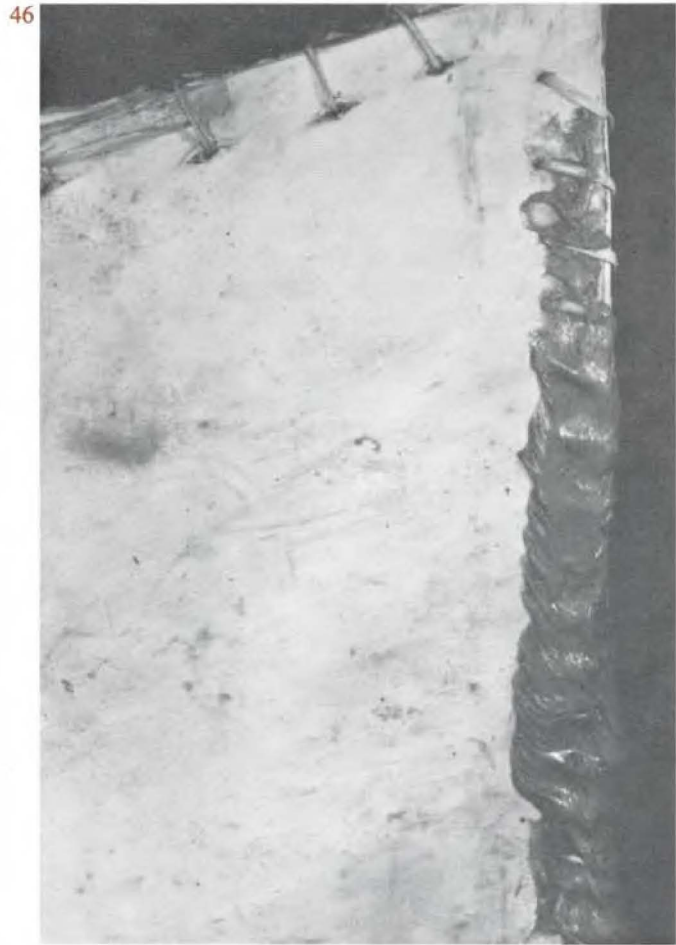
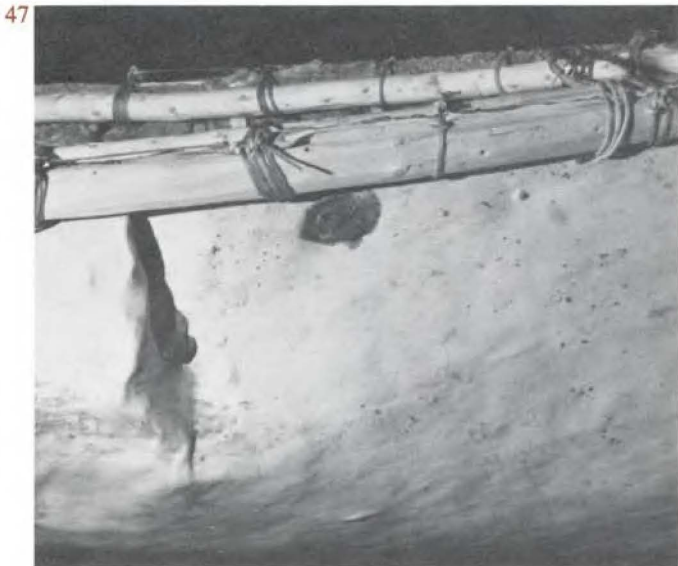

49

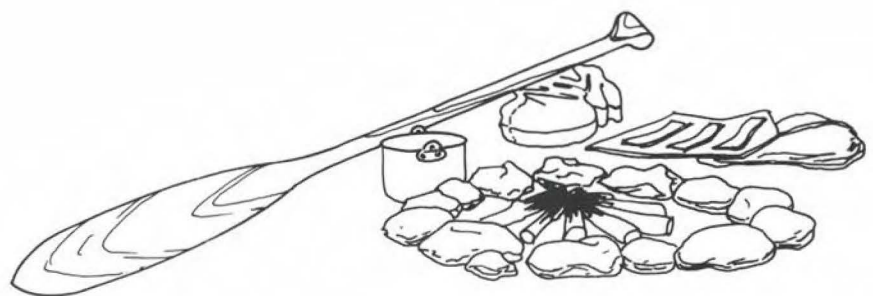





## John Takolik

I was born on Hector Island, which is about midway between Cape Dorset and Lake Harbour at the south end of Baffin Island. I'm not sure of the exact date. Government records say 1909, with no day or month shown.

I grew up in Cape Dorset. We left there in 1934, travelling by ship to Lake Harbour, Killingnuk, Pangnirtung, Broughton Island, Clyde River and Pond Inlet. Finally we reached Talurut near Resolute and stayed there for two years. Then we moved to Arctic Bay and lived in the area for two years before moving to Ft. Ross on Somerset Island.

Ft. Ross was a good place to live. The wildlife was abundant and everyone had a good dogteam. Most people made a good living trapping white foxes. When the price was high I caught enough to pay for one boat and half of another. I never used the old trapping method for white fox — a pile of rocks like an igloo with a hole in the top and bait inside. After the fox enters the trap, he can't get out.

Hunting animals from year to year was not always the same. Sometimes there would be more of one kind and less of another, so you had to be able to hunt what was available. We hunted walrus, beluga, bearded seal, ringed seal, and polar bear, but never bowheads.

We stayed in Ft. Ross after the Hudson's Bay Company moved its post to Spence Bay. Aircraft would parachute us food, supplies and clothing. We shared these items amongst ourselves. The next winter we moved to Spence Bay. At first there were no buildings

for us to live in, so we continued using tents and igloos.

In those days the only way we travelled was by dogteam and boat. When snowmobiles first came out, a lot of people fell through the ice. It is also harder to hunt with a snowmobile. Dogs can sense animals and let you know, but today you miss a lot of animals because you don't see them until you are close to them.

A harpoon is a very useful and handy tool to have. When used properly, you can check for thin ice with it. You strike the ice once and if it goes through, it's not safe. If it takes a hard second blow to go through the ice, then it's okay, but if the second blow goes through easily, it's not safe.

The first outboard motor I ever used was in Ft. Ross. Later I bought my own in Spence Bay. There weren't too many around in those days. People mostly used inboard-outboards to hunt. Seals weren't afraid, sometimes they would come right up to the boat.

Many kinds of rifles were used, but the most common one was the .30-30 calibre, lever action. We still used seal oil lamps, even after we moved to Spence Bay. Seal blubber was used the most, but we also used any kind of animal fat. In the old days, seal oil lamps were the only source of heat, light, and drying clothes.

*Joe Ashevak and Lloyd Jones  
Spence Bay 1984*

# *Simple Ways to Prepare and Eat Country Food*



*Terry Rebizant*

## **Caribou Porridge**

Cut and boil chunks of caribou, as for a stew. When the meat is tender, stir in a couple of handfuls of rolled oats. Serve when the oats are cooked.

This is a quick and hearty meal, and easy to make when hunters return to camp after a long day out in the cold.

*Lloyd Jones, Spence Bay*

## **Liver in Caribou Stomach**

This recipe will work only with freshly killed caribou. While you are skinning, cut the liver into thin strips ( $\frac{1}{2}$  cm). Place the strips inside the caribou stomach (mixed with rumen contents) for 10-15 minutes. By the time you have finished skinning and quartering your animal, the liver is ready to eat. An instant meal when time is short and travelling distance is a concern.

*Joe Ashevak, Spence Bay  
Colin Adjun, Coppermine*



### Caribou Tripe and Bridal Veil

In the Eastern Arctic, caribou stomach (or tripe) is often eaten. It is rinsed off and boiled or consumed raw. It is said to be a good source of vitamins. The mesentery (or bridal veil) is a transparent membrane which surrounds the intestines and is laced with strings of fat. It too can be boiled and eaten, and is very tasty.

*Mike Labine, Cape Dorset*

### Blood Gravy

The blood of moose or caribou was always saved in the old days. This was done by cutting into the jugular vein in the neck and collecting the blood. The animal's stomach was cleaned and used to transport the blood back to camp. The women cooked it with a little flour and water, making it into a sort of gravy. It may not sound very tasty but it was a mainstay in the bush.

*Mary Ann Rabesca, Yellowknife*

### Dry Meat

Dried caribou meat is a favourite in the North and easy to make. Simply cut the meat into thin sheets and hang from a ceiling rack inside your house or tent. In a few days it'll be dry and ready to eat. You may have to turn the meat over so that it dries evenly throughout. It can be



*Making dry meat.*

eaten when it's completely dry, or when the middle is still a little spongy. Because the meat is so lean, most people like to eat it with lard. Using a piece of dry meat like a spoon, dig out a chunk of lard from its container and eat both at the same time. Some people like to salt the lard before doing this.

You can use just about any part of the animal to make dry meat. It's easiest to do and tastes best when you use the tenderloin strips from the backbone, or meat from a leg. It takes a sharp knife or ulu and considerable skill to cut a large thin sheet of meat perfect for drying. Don't be discouraged if your first efforts result in odd-looking pieces. They'll taste just as good when they're dry. Some parts from the animal are ready-made for drying, such as the diaphragm and the thin flap of meat and skin which covers the belly. Because of the membranes, these pieces will be chewy.

Below the treeline, people like to dry the meat outside in teepees where they can smoke it at the same time. A small fire is built under the drying racks, then pieces of rotten punky wood are placed on top. The fire smokes and smoulders and a new taste is added to the meat. The smoke also keeps the flies away and prevents them from laying eggs in the meat. Make sure that dogs or ravens can't get in to steal the meat.

*Ed Hall, Yellowknife*

### Eskimo Ice Cream

Grind up or pound a quantity of caribou fat. Melt fat over low heat until you have about 10 cm of grease in a bowl.

Boil caribou meat from the backbone and save the broth. Let the meat dry for a little while. Grind up half the meat and cut the other half into small pieces. Stir meat slowly into the melted fat (keeping the temperature low enough so that the mixture is not too hot to touch). If the oil starts to get stiff, add some hot broth to soften it. Flavour with salt.



*Dry meat can be pounded to make pemmican.*



It takes about three hours to make and must be done without any interruptions. When it is ready, it has the consistency of lard at room temperature. Then it is frozen before being eaten. Excellent with bread or meat.

Note: This is the Western Arctic version. Another variation uses seal fat instead of caribou fat, dry char roe and berries instead of caribou meat, and water instead of broth.

*Fred Elias, Coppermine*

### Raw Frozen Char and Caribou

Stand a char on its nose and split it down both sides of the backbone. Chop off bite-sized chunks (if the char has not been cleaned, the kidney and other innards will simply fall away from the flesh) and pop them into your mouth. You can remove the bones as the pieces thaw. For caribou, it's the same thing. Cut off frozen slivers of raw meat and eat them. If you've got it, dip the pieces of char or caribou in seal oil, or eat with seal fat. Strange as it seems, eating raw frozen char or caribou really warms you up. Everyone should try it.

*Rupert Tinling, Yellowknife*

### Fish Egg Bannock

5 cups flour  
4 teaspoons baking powder  
1 teaspoon salt

2 cups water  
3 tablespoons lard  
3/4 cup fish eggs

Combine dry ingredients. Stir in fish eggs until separated. Melt lard and add with water to the dry ingredients. Stir until mixture forms a pliable dough and knead. Flatten the dough into a round cake and poke a few holes in it with a fork. Fry or bake in a medium hot oven (175° C) on the middle rack for 14-20 minutes, until golden brown.

The amount of fish eggs may be varied to taste. Any fish eggs can be used.

*Lloyd Jones, Spence Bay*

### Whitefish Eggs and Pipes

Remove the eggs and stomachs from six fresh whitefish. Clean the stomachs ("pipes," as we call them), then fry them with the eggs in a tablespoon of lard. Add onions if you wish, and salt and pepper to taste. Stir occasionally and cook till nicely brown. Good with boiled fish or bannock.

*Minnie Carmichael, Yellowknife*



From left to right: 5 lake trout stomachs, 2 rows of whitefish eggs, 2 rows of lake trout eggs, and 2 lake trout testes. At the top: a whitefish stomach.

Tessa Macintosh



### Boiled Arctic Char

An easy and tasty way to cook char anywhere: Clean the fish and, without removing the skin, cut it up into chunks. Put the chunks and head in a pot and cover with water. Boil, skim off any oil or fat, then add a package of soup mix, salt to taste, and cook a bit longer.

*Mike Labine, Cape Dorset*

### Fish Soup

Clean and scale one whitefish. Boil in a pot of water until tender. Remove the fish from the water and take out the backbone and rib bones. Break the fish into small pieces and return to the pot. Add salt and pepper, and boil gently for another 15 minutes. Thicken the soup by making a paste of flour and water and adding it to the soup, or add a package of cream of mushroom soup mix.

*Mary Ann Rabesca, Yellowknife*



*A lake trout caught in winter on a line set through the ice.*



*Dept. of Culture and Communications*

*A quick bite to eat on the trail.*

### Roasted Fish

Francis Tatti of Ft. Franklin showed me how to cook fish without using a pan. It was during the winter and we were camped for the night at Deerpass Bay on Great Bear Lake. Francis had a nice big whitefish, which he gutted and suspended by the tail from the ridgepole of the tent using snare wire. He positioned it so that it was beside the airtight stove, no farther than a hand's breadth away. When it was cooked on both sides from the heat of the stove, he took it down, peeled off the skin, and we had a nice feed of fish.

*Ed Hall, Yellowknife*

### Walrus Stew

Cut walrus meat into small chunks and place in water. Some people add pieces of skin, or leave the skin on the meat.

Add chunks of walrus fat and intestine. Clean out the intestine first by pushing a small piece of fat through it.

Add salt to taste, and dry vegetable soup mix.

Walrus meat is fairly tough, so it must be cooked for quite a while if you like it tender. When it is fresh, and people are hungry for it, they only cook it for half-an-hour or so. The tenderest meat comes from the brisket, or breastbone area.

*Pauloosie Kilabuk, Frobisher Bay*

### Clams in Walrus Stomach

The soft bodies of clams are often found in walrus stomachs. Just rinse them off and eat them. They are quite tasty.

*Pauloosie Kilabuk, Frobisher Bay*



Ed Hall

*Pauloosie Kilabuk skinning a ringed seal at the floe edge.*

### **Raw Seal**

If you're hunting ringed seal and don't want to stop to cook, a fast meal of raw liver and blubber can be eaten on the spot. The person who's killed the seal cuts open the belly, takes out the liver and slices off chunks of blubber. Nobody eats until he has cut up the food into small mouthsize pieces. If many hunters are in the area, the kidneys and heart are sometimes eaten as well. To quench the thirst, blood may be drunk but only in small quantities. If too much blood is drunk, additional water or fluid is craved.

*Joe Ashevak, Spence Bay*

### **Boiled Seal**

Boiled seal at the floe edge makes a hearty meal for hungry hunters. Cut up chunks of seal meat and seal fat, and place them in a pot of water. Take the long intestine from the seal and separate it from the stomach and the short intestine. (The long intestine is thin, the short intestine is thicker and ends at the anus.) Pull the long intestine through your closed fist to empty it, then cut it into pieces like big macaroni. Place it in the pot with the chunks of seal meat and fat. A little salt and dried onions will enhance the flavour. Boil and eat. Don't forget to drink the broth, it's very nourishing.

*Rupert Tinling, Yellowknife*

### **Hare Stew**

After the hare has been skinned and cleaned, cut it up into pieces and brown in a frying pan. Place the pieces in a large pot with three cups cold water. Add salt, pepper and vegetables (celery, carrots, potatoes) and cook until tender. Thicken the stew by mixing flour and water into a paste and adding it to the stew.

*Mary Ann Rabesca, Yellowknife*

### **Duck Soup**

Pluck, clean and wash a duck. Cut it up and put the pieces in a large pot filled halfway with cold water. Add salt, pepper, dried onion flakes and one cup of rice. Simmer for an hour-and-a-half. If you find there is too much grease collecting on top of the water, skim it off before adding the rice.

*Minnie Carmichael, Yellowknife*

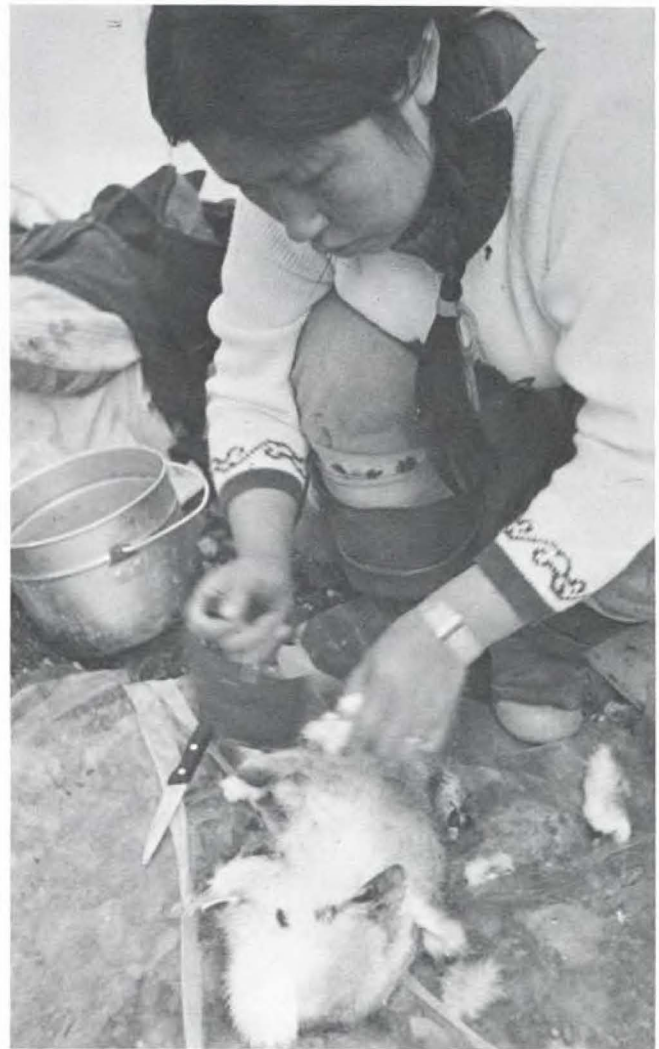

Bob Wilson

*Preparing a duck.*





Public Archives of Canada

*Collecting birch syrup.*

### **Roasted Beaver**

First you must catch the beaver. Take it back to camp and let's hope the wife knows what to do with it. If not, try this:

Skin the beaver and take out the insides. Be most careful when removing the scent glands, as they can leave a funny taste to the meat. Wash the meat and cut off the tail. Put the beaver on a spit or a Y-shaped stick and slowly roast over the campfire. Turn the stick frequently.

Beaver and tea make a fine meal in the springtime.

*Mary Ann Rabesca, Yellowknife*

### **Beaver Tail**

Remove any fur left at the base of the tail. Put the tail into a pot and boil until soft (maybe half-an-hour). Remove from the pot and peel off the hard skin. Roast over a fire, turning it frequently until the meat is tender. It's very sticky, but kind of tasty.

*Mary Ann Rabesca, Yellowknife*

### **Birch Syrup**

Select a heavily wooded birch area within easy walking distance of your camp or vehicle. Twenty trees of 15 cm diameter or more will produce about 90 litres of sap when there is just a trace of snow left on the ground in spring.

With a 3/8 in. (9 mm) bit and brace, drill a hole upwards into each tree at a 30° angle and approximately one metre from ground level. Remove the top of a tin can and bend it to form a 45° angle. This will serve as a spout. With a hammer, drive the tin can top into the tree just below the hole you drilled. Then nail a pail under the spout to catch the sap. A 15 cm diameter birch tree should produce about 4.5 litres of sap per day. Collect the sap every day.

Add one tablespoon of sugar for every 13.5 litres and boil. Thirteen-and-a-half litres of sap must be reduced to about 284 ml before a syrupy consistency is reached. Care should be taken at this stage as overboiling will turn the syrup into a hard mass within minutes.

A deep amber syrup is the result of your efforts.

*Bob Hunter, Fort Smith*

### Cranberry Jam

Fill a large pot with water and boil. Add three cups of cranberries, two cups of sugar, and a teaspoon of cinnamon. Boil until the berries start to burst and remove from heat. The mixture should be very thick. Eat with bannock or serve as a sauce with wild meat.

*Mary Ann Rabesca, Yellowknife.*

### Tundra Rock Frying

Find three rocks and position them as shown below. These will be used to contain a fire, so they should be 30 cm high or more. The rocks should be positioned so the wind is blowing from one side, not from the front or back. This improves burning and also prevents smoke from blowing into your face. Then find a flat rock which can be set on top of the other three. This rock will be used to cook on, so it should be fairly thin (2 cm or so).

Gather several large armfuls of heather. Get a fire going inside the rock base, then put the top rock in position. Cut a few chunks of seal fat and place them on the cooking rock. As the fat melts, smear it around over the top of the rock. Cut thin slices of meat and place them on the rock to cook.

*Joe Tigullaraq, Clyde River*

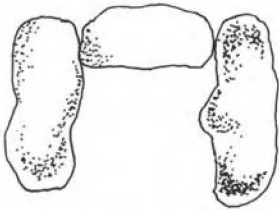

TOP VIEW  
WITHOUT COOKING  
ROCK

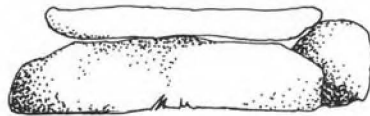

SIDE VIEW  
WITH COOKING  
ROCK



Ed Hall

*How to get a drink if you've forgotten your tea pail.*





## Wallace Lucas

Wallace Lucas was born in 1914 about 20 km northwest of Aklavik. He grew up in the area without receiving any schooling. He remembers hunting and trapping and the hardships they had. At times there was nothing to eat and trapping wasn't too good.

In 1935 he married his wife, Ruth.

In 1936 his parents moved to Tuktoyaktuk and he went to Reindeer Station (which is now abandoned), where he worked for the government as a reindeer herder. In 1952 he and a partner (Peter Rufus) bought 3,000 reindeer and went into business for themselves. Each fall the men and their families would head out on foot with their reindeer to Husky Lakes, where they set up their main winter camp and from which shifts of two or three men at a time would set out to patrol the herd. It took three or four hours to make a circuit on skis accompanied by herd dogs. Two circuits were made each day, once in the morning and once in the evening. In spring, with the help of "sled-deer" the camp was moved and eventually relocated near Tuktoyaktuk for the summer. Once a year the reindeer were rounded up for slaughter. The meat was sold locally to hospitals and schools. Eventually, however,

the herd failed to prosper and was sold back to the government.

In 1958, having heard that trapping was good on Banks Island, Wallace bought 11 dogs and moved to Sea Otter Harbour, which is on the west coast of the island. He stayed there for one year, then moved to Storkerson Bay. Trapping, which was mainly for white foxes, was very good.

He recalls one time during the cold winter months when he was out on his trapline and his dogs took off after some muskoxen. He chased them for quite a while and finally caught them, but in the process froze his lungs and ended up with pneumonia. Ever since then his health hasn't been good, but he still hunts and traps today.

In 1960 he moved to what is now Sachs Harbour and resides there to this day. In 1968 he switched from dogs to a snowmobile. It was called "Autotoboggan". His favourite kind of rifle is a .243 Winchester. Today he still hunts and traps with an Alpine skidoo.

*Paul Voudrach, Tuktoyaktuk 1983*

*Minnie Carmichael, Yellowknife 1984*



# Troubleshooting Snowmobiles and Other Tips



Fran Hurcomb

## Cold Weather Starting

In really cold weather (-40° C and lower) there are a number of things you can do to make starting easier:

When stopping overnight, remove the drive belt and take it inside. Warm it up in the morning so it is good and flexible before putting it back on the machine. No more burning belts during morning start-up.

Give ten good pulls on the starter cord to loosen up the engine before turning on the key. This will reduce the chances of flooding and limber up the fan belt.

*Rick Letkeman, Ft. Rae*

If your engine is really stiff, take out the spark plugs when loosening up the engine by preliminary pulls. Many people also carry a blow torch which they use to warm up the block and muffler. If you use a blow torch, though, make sure you don't fry any wires. If all else fails, you can always drag your machine inside your tent to warm it up.

*Ed Hall, Yellowknife*

## Spark Plugs

If a spark plug goes dead and you have no spare, try heating it up for five minutes on a Coleman stove. Let it cool, then put it back into place and it should run again.

*Winston Fillatre, Inuvik*

If a spark plug becomes loose as a result of worn threads, wrap the threads with foil from a cigarette package and re-tighten it.

*Winston Fillatre, Inuvik*

If the spark plug threads in the cylinder head become stripped and the plug will not stay seated, you can try this as a last resort: Install the plug as best you can, then hammer small indentations in the cylinder head until the plug is securely locked.

*Fred Elias, Coppermine*



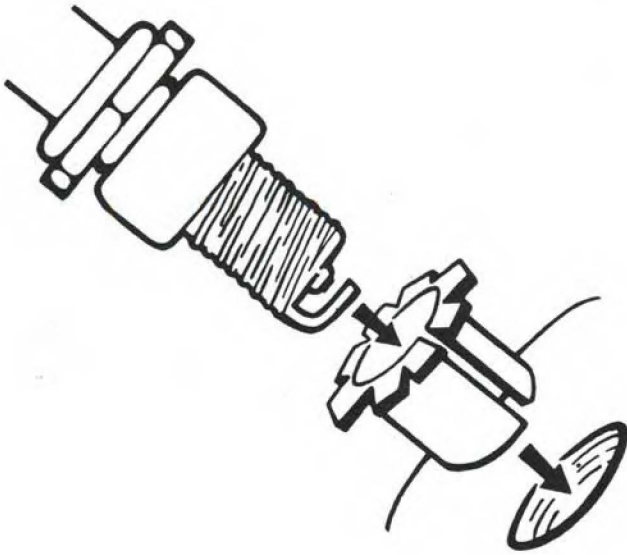

Or you can try this method: Cut a strip from a tin can (or use any other thin metal). The strip should be 5 mm wider than the spark plug threads but only long enough to wrap around the threads once. On one of the long sides of the strip make a series of cuts about 1 cm apart and about 5 mm deep. Bend the metal tabs back to form a 90° angle, then insert the metal piece into the stripped spark plug hole.

Take a spark plug and file one groove at right angles deep across the threads at the tip of the plug. This will enable the spark plug to cut threads into the metal insert.

Install spark plug, line up and tighten slowly until the base of the plug touches. Do not overtighten.

This tip is recommended only as a last resort.

*Lloyd Jones, Spence Bay*

### Blown Piston

Puncturing of a piston can be caused by a faulty ignition system or incorrect amount of gas and air mixture due to clogging of fuel lines, fuel pump or malfunctioning carburetor. In any case, the hole is usually about 1 to 1.5 cm in diameter on the top of the piston. You can use an empty bullet casing to plug up the hole. Cut the empty casing 1 cm or so from the bottom and place it in the hole with the bottom facing up. Using the flat or blunt end of a cold chisel (or any metal rod flat and wide enough), hammer the casing carefully into the top of the piston. You have to mushroom the top and bottom so that the casing will stay in place. You'll also probably have to file down some of the casing to make sure it is flush with the top of the piston. The hole has to be filled in completely. Before installing the piston make sure there are no loose chips or filings anywhere. I have known guys using a piston repaired in this fashion for as long as two months, so it can definitely get you home safely.

*Joe Tigullaraq, Clyde River*

The hole in a blown piston can be repaired by the correct size nut and bolt. Using a round file, shape the hole so that it will admit the bolt. Screw the bolt into the hole and fasten underneath with the nut. Use a file to smooth the top of the bolt so that it is flush with the top of the piston.

*Fred Elias, Coppermine  
Pauloosie Kilabuk, Frobisher Bay*

### Frozen Carburetor

If the carburetor on your snowmobile should freeze up and you don't have any methyl hydrate handy, and you're in a hurry, you can melt the ice inside by urinating on it.

*Winston Fillatre, Inuvik*

### Adjusting Points Without a Feeler Gauge

If you don't have a feeler gauge, or don't know the correct gap, use a strip of cardboard from a cigarette package or a book of matches.

*Rick Letkeman, Ft. Rae*

### Damaged Head Gasket

Soft aluminum (such as the lid of a cooking pot) makes an adequate replacement. Place the aluminum flat on the cylinder head block and shape by tapping gently along the edges using a ball-peen hammer.

*Fred Elias, Coppermine*

### Broken Ski

Because most of the caribou hunting areas in Baffin don't have much snow, a brand new pair of skis can wear out in a matter of days. The land is also very rocky, so if you're not careful, a broken ski will be the result. Usually the ski breaks off right behind the front end of the spring.

The spring is flexible enough so that you can overlap the broken ends of the ski and bolt them together.

*Joe Tigullaraq, Clyde River*

If the spring on your ski breaks, try carving a piece of wood so that it fits underneath the spring. Place some pieces of clothing (socks or mitts) between the bottom of the spring and the top of the wood, then tie or wire everything together. In the east you can use a crosspiece from your komatik for this.

*Pauloosie Kilabuk, Frobisher Bay  
John Stevenson, Igloolik*





### **Broken Suspension Spring**

Depending on where the break is, it may be possible to repair by heating the spring on a Coleman stove. Unwind one revolution of the spring and straighten out.

*Fred Elias, Coppermine*

### **No Spark**

When there is no spark at the plugs, the CD box is sometimes faulty. If the box is cracked, it may be shorting out against the frame. If you have no electrical tape, try inserting a thin piece of plywood, some cloth, a piece of rubber, or any other insulating material between the CD box and the frame. If the symptom persists after bolting the CD box in place, add more insulating material. In most cases it will get you home. The CD box is usually located below the carburetor bolted to the body of the snowmobile.

*Joe Ashevak, Spence Bay*



*NWT Dept. of Culture and Communications*



### Belts and Tracks

Just about the only material that people above the treeline have found to replace a drive belt is walrus hide. Pantyhose can be used to replace a fan belt.

*Ben Kovic, Eskimo Point*

To replace a broken fan belt, use 1/4 in. (6 mm) nylon rope and splice the ends together to the original size of the fan belt.

*Fred Elias, Coppermine*

Once, when my fan belt broke and I had nothing to replace it with, I removed the engine cowling as well as the fan belt cover, and by driving slowly managed to get safely to my destination, which was about 15 km away.

*Winston Fillatre, Inuvik*

To mend a broken track, use wire to sew the ends together. Copper wire is preferable. Use crisscross stitches and make sure the knot is on the outside of the track.

*Fred Elias, Coppermine*

### Broken Handlebars

If your handlebars break, you can clamp vise-grips on each side of the steering column and lash them to a board stretched across the handlebars.

*Cliff Cook, Aklavik*

### Cracked Nut

On a trip between Arctic Bay and Bell Bay one of our machines came down with a cracked crankshaft nut. A groove was filed around the nut, then vise-grips used to close the crack. A strand of heavy wire was tied around the nut in the groove and twisted tight. It was good for 160 km.

*Mike Ferguson, Frobisher Bay*

### Towing a Snowmobile

Should it be necessary to tow a broken machine and a sled or komatik is not available, you can do it the following way. Remove and replace the skis so they face the rear of the machine. Remove the drive belt, lift the rear end of the machine and tow home backwards.

*Mike Labine, Cape Dorset*



*Ed Hall*

### Travelling in the Spring

When travelling in the spring it's often necessary to remove the hood of your machine to prevent it from overheating.

*Mike Labine, Cape Dorset*

### Mending Holes in a Boat

If you have a hole in your canoe or boat and are in an area with spruce or pine trees, you can use pitch from them for patching. If there are no trees, collect a length of nylon rope, or several plastic bottles of the type used for outboard motor oil, and cut up into small pieces. Put in a pail of some kind and melt the plastic. Pour over the hole and it will harden and seal the hole.

*Bob Hunter, Ft. Smith*

*Bernie Bergman, Ft. Smith*

### Locating Whales

Watch for several seagulls together when travelling on the ocean away from land. If there are whales in the area, this is usually a clue as to where the whales are.

*Bob Hunter, Ft. Smith*

### Headaches

If you have a headache in the bush and are without aspirin, cut some fresh young willow and chew the bark. Willows have a high concentration of acetylsalicylic acid.

*Bob Hunter, Ft. Smith*

### Caching Fish

George White tells me that when he piles his fish in the yard, he hangs a gillnet around the pile just high enough so it will blow and move freely in the breeze. He ties a few pieces of bright cloth or plastic to it, and when bears see the net moving, they will not go near his fish pile.

*Cliff Cook, Aklavik*

### Beaver Bandage

The short fluffy fur of a beaver pelt makes an excellent bandage, and since beaver fur is often used below the treeline as trim for parkas, mitts or mukluks, there is usually some available. Simply press a wad of the fluffy fur against the cut and allow it to soak up any excess blood. After it dries it makes an effective tight-fitting dressing (like a thick scab).

*Walter Bayha, Ft. Franklin*

### Lighting a Stove in Cold Weather

After pressurizing the tank, place a small amount of absorbent material (e.g. toilet paper, caribou hair) in burner cup. Open tank valve and squirt a small amount of gas onto burner, soaking the absorbent material. Install the

tank for use and light the gas in the burner. This will preheat the generator, making the stove easier to light.

*Rick Letkeman, Ft. Rae*

### Thawing Out Marten

Thawing frozen marten inside a tent can be done easily by placing them in a sturdy bag and hanging it from the ridgepole at the back of the tent. At night, when the fire in the stove goes out, put two or three inside your sleeping bag down by your feet. By morning they should be soft enough to skin.

*Walter Bayha, Ft. Franklin*

### Packing a Komatik

Loads on komatiks remain much more intact if they are placed on a foam mattress. The foam compresses when the load is tied down, but keeps steady pressure on the articles despite the pounding the komatik takes as you travel. It also reduces the chance of breaking fragile articles.

*Mike Labine, Cape Dorset*



*Doug Heard*

### Fishing for Burbot

In late fall and early winter fish for burbot (loche) at night in very shallow water under the ice at the mouth of very small creeks that flow into rivers entering the Mackenzie. If you don't have any fishing tackle, use a bent nail hammered into a piece of bone. The liver of burbot is large and rich in vitamins A and D.

*Bob Hunter, Ft. Smith*



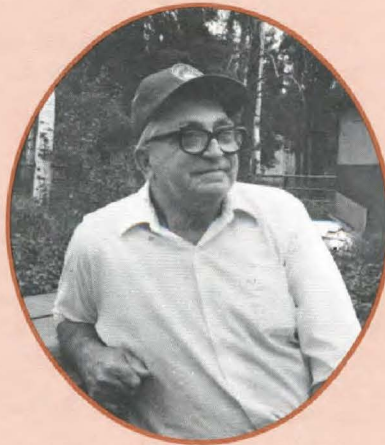

## Rene Mercredi

Rene was born in Ft. Smith on August 4, 1915. He started trapping when he was 17 years old and for the next 32 years it was his main source of income. Each year he spent from October to June on his 240 km trapline, returning to town for brief visits at Christmas, the middle of February, and at Easter. He maintained this routine even after he married and began raising a family. Occasionally he and a neighbouring trapper, Pie Kennedy, would visit each other or exchange notes, but for the most part he was alone and without the benefit of a two-way radio. He travelled by dogteam and used eight cabins on his trapline. Two he shared with Pie, the rest were his own. Four of these he bought from Frank Conibear when Frank packed up and moved to the barrens in 1942.

The year 1960 stands out in Rene's mind because that was the only time he ever took his family out on the trapline. He remembers that lynx were practically worthless then. He trapped 25 or so that year because his kids liked the meat, and eventually sold the skins for \$5 each to a priest who was going to cut them up and use them for parka trim. Twenty years later lynx sold for over \$1,000 each.

In 1964 Rene signed on as a government game officer. From 1965 to 1977 he worked in Ft. Rae, where a lot of his work involved helping trappers. Twice a year he and his patrolman would go out with a trapper, survey an area for fur and help build a cabin. On one trip they discovered they'd left behind most of their groceries. Luckily they found a good fish lake. For a whole month they ate fish for breakfast, dinner and supper. They fried it, boiled it and roasted it. They were glad to get back home and change their diet.

"I know that Calder River area like the palm of my hand," Rene says. "And you know something? The maps are wrong for that river." Rene and two others were travelling along the river after completing another sojourn in the bush, and were to rendezvous with an

airplane. They thought they had made it in time when they discovered an unmapped stretch of rapids. Rene's companions portaged the heavy canoe while Rene packed the remaining gear. There was grizzly sign in evidence, so Rene carried everything in little stages, keeping their gear in sight at all times. The rapids turned out to be 6 km long and they did not get everything safely across until after nightfall. The next day they ran out of gas several kilometres short of their destination.

"It just about broke their hearts," says Rene. "We still had to cross part of Hottah Lake. It's a big lake, there were whitecaps on it, and we were heavily loaded. We made for an island and built a signal fire. When the plane came, we were lucky he saw it.

"The Calder River area was a good place for moose," he adds, "also mosquitoes. Once when we were travelling along the river, we spotted something up ahead, a little bump in the water. When we got close, a moose jumped up and ran away. The mosquitoes were so bad, the moose had been completely submerged except for its nose."

In 1977 Rene moved back to Ft. Smith to become Resource Development Officer at the regional office. In 1978 he was chosen by his peers as "Wildlife Officer of the Year" in the Northwest Territories. In 1980 he retired from government service at the age of 65.

Since then Rene has kept busy as chairman of the Wood Buffalo National Park Management Planning Committee, as a member of the Fire Management Committee, and as a community member of the National Parole Board.

Rene says that if he had his life to live over again, he'd do it all the same.

*Ed Hall  
Yellowknife 1985*



# Trap Sets

by Rene Mercredi

## Beaver

There are two phases of beaver trapping, one in the winter and one in the spring and fall. The latter are open water sets located on the edge of streams, ponds and lakes where beaver have their feeding or stopping places. At the edge of the water scoop out a shallow level depression about 12 cm deep and big enough to hold a No. 4 jump trap or a No. 4 double-spring leghold trap. Water should fill the depression as soon as it is scooped out. Tie a length of heavy twine to the trap chain (about 15 cm from the swivel), then tie the other end to a flat rock weighing about 3.5 kg. A piece of 1/4 in. (6 mm) rope about 1.5 m long is tied to the trap ring at the end of the chain and to a long dry pole. The trap is set in the shallow depression with the pole and rock positioned underwater as shown in the illustration. When the trap is

sprung the beaver will jump into the water, and the rock will keep it submerged and prevent it from reaching shore again.

Dry sticks slanting away from the trap are placed to steer the animal into the trap. Five or six pieces of green poplar saplings, about 30 cm long and up to 2.5 cm in diameter, are cut for bait. They are placed about 30 cm from the trap at the back of the depression. They should be partially peeled and the bark placed beside them. Finally, cut a piece of beaver castor and wrap it into a ball of hay or grass and tie it to a dry willow about 30 cm long. Stand the willow behind the green bait sticks. Back your canoe away from the set and using your paddle splash the set with water. This will help to kill the human scent and freshen up the bait sticks. Visit your traps every

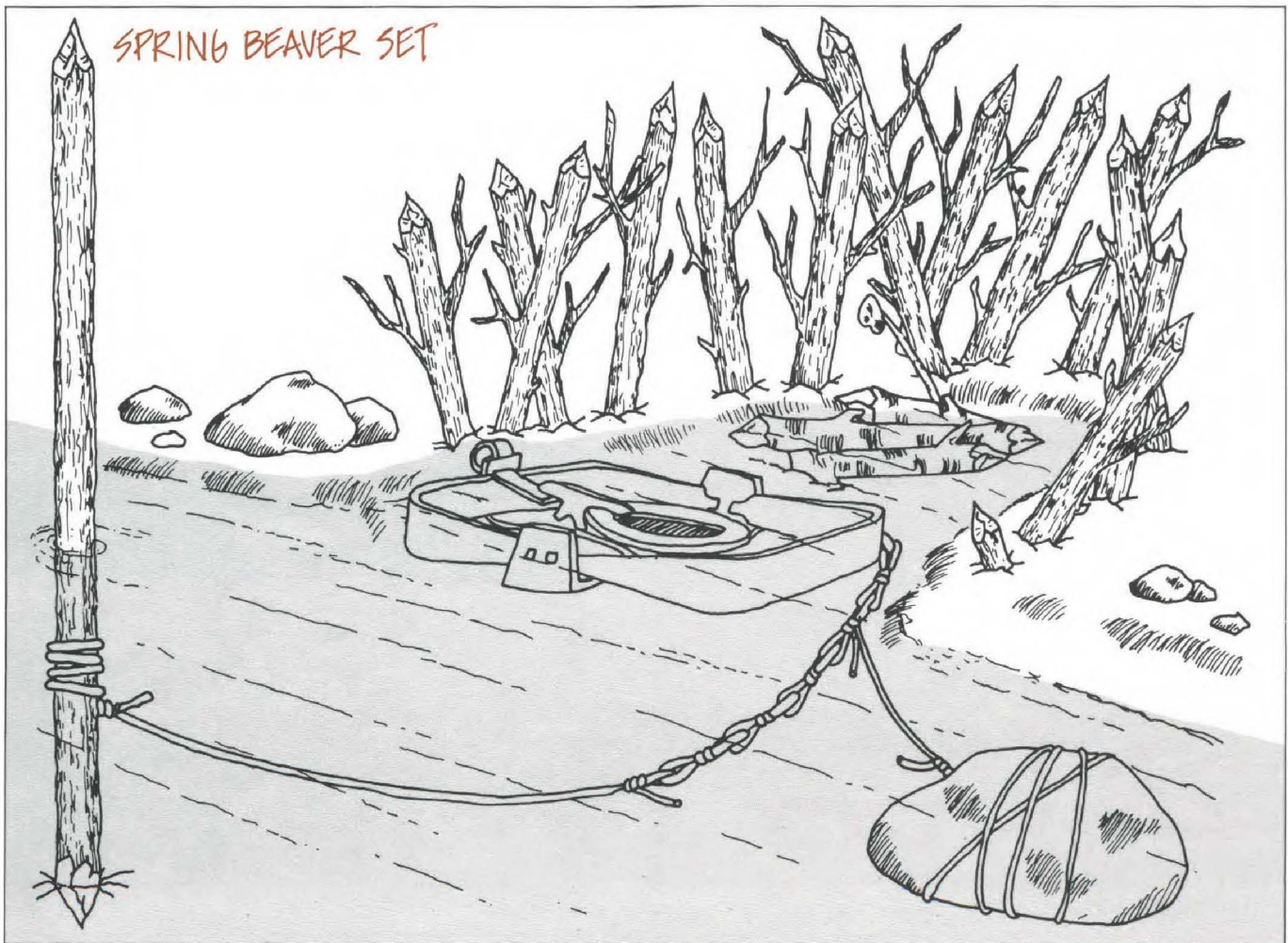



day, especially where the water level fluctuates, which could leave your trap too deep or high and dry.

In the winter, the single and double block sets are the best I have tried. Locate a live beaver lodge, then shovel off the ice in front of the lodge and try to find the runway. Usually a first-year lodge will have only one located at the front centre of the lodge, while a two-year lodge will normally have two, one on each side of the lodge's feed pile. Usually there will be lots of air bubbles showing through the ice where the runway is, and the ice will be thinner there than elsewhere.

When you find the runway, cut a hole in the ice with a chisel (about half-a-metre in diameter). Nail the block, the two support sticks and the bait sticks to a pole about 2.5 m long and 5-6 cm in diameter. The block should be positioned so that it is 23 cm from the bottom of the ice, with the bait and support sticks right up against the edge of the ice. (If the block is set deeper, the beaver will swim over the trap and spring it.) The trap or traps (No. 4 jump) are held in position on the block by a couple of nails. The trap pan should be about 10 cm from the bait stick and the trap ring at the end of the chain should be wired as far as it can go to the bottom of the pole. When the trap is sprung, it should come off the block easily.

The set is inserted into the hole facing the lodge. A long piece of green poplar (about 1.5 m long and 1.25 cm in diameter) is inserted on the chain side of the single block set and pushed into the stream bottom. Then the hole is filled with snow.

These sets are always made under old ice, and green wood is never used for the block, trap pole or support sticks. Once a block set is made it can be used every year, thus saving you the trouble of making new ones. When you are finished trapping the lodge, just hang your set nearby for use next year. With practice you can become a good under-ice beaver trapper.

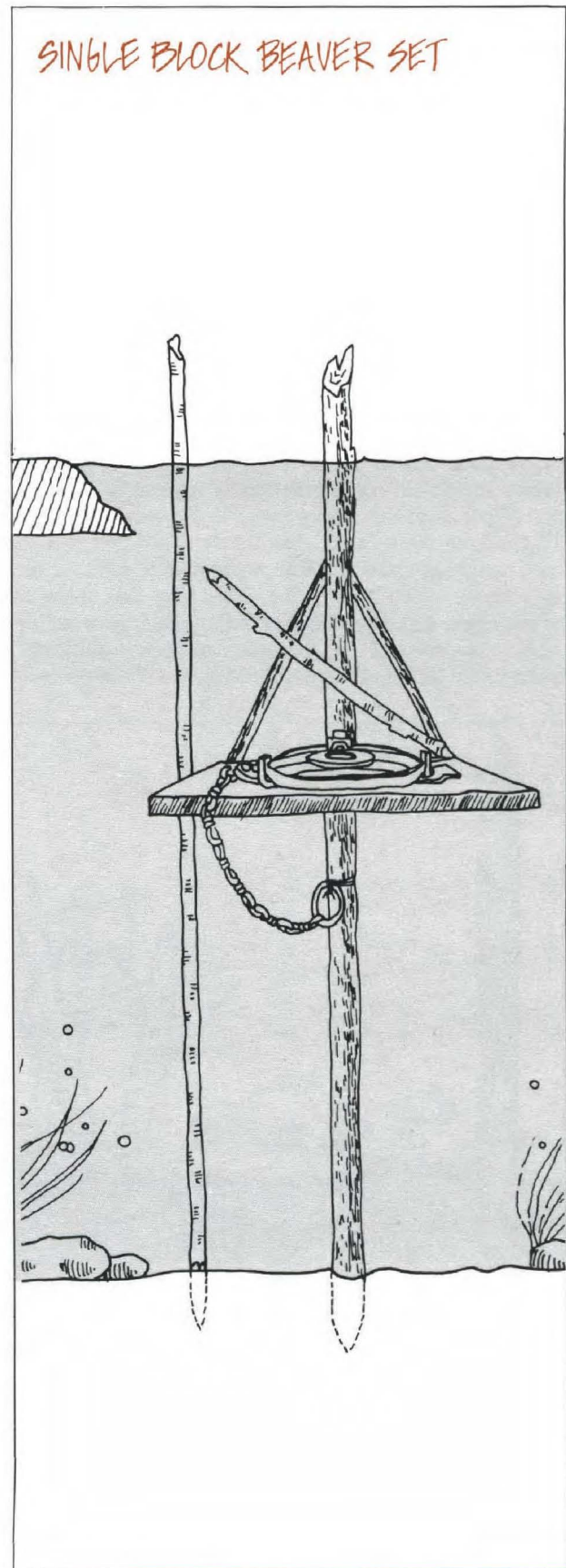

DOUBLE BLOCK BEAVER SET

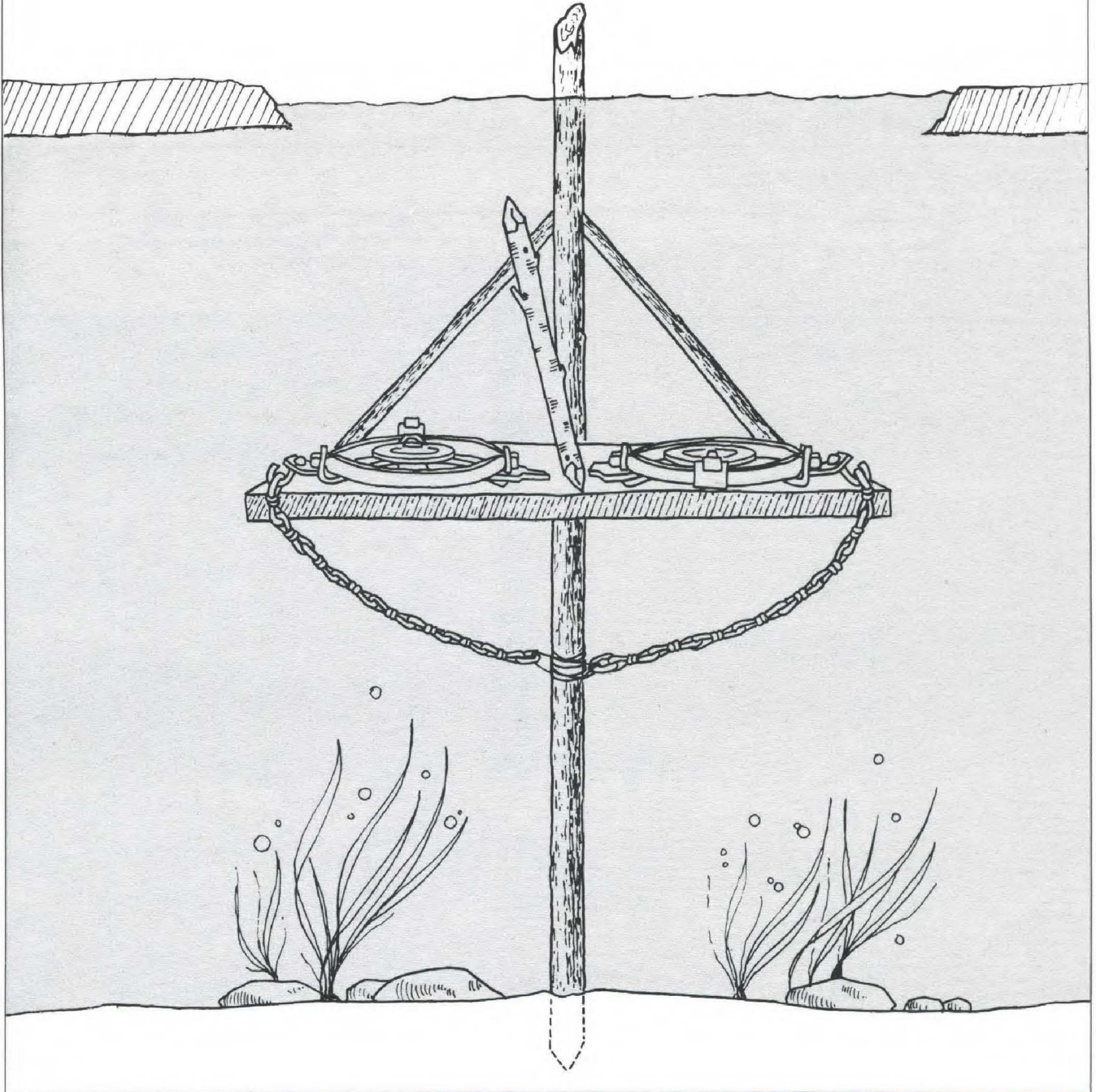



## Muskrat

Musk rats are easy to catch but difficult to hold. For this reason, all sets must be humane — using either a 110 Conibear or a leghold trap in a drowning set.

In the fall or early winter when the ice is not too thick, find a spot between a muskrat pushup and the shore. About 1.2 m from the pushup, cut a hole in the ice. Bait a 110 Conibear with a piece of carrot or parsnip on the trigger and hang the trap below the ice as shown. This method makes it unnecessary to break into the pushup to set a trap.

A spring muskrat set that is very good, especially on a river or creek where the water level fluctuates, is a small raft built with dry logs. The logs are nailed together and the middle one has an opening for a pole to be inserted. The pole is fixed in the stream bed. Two No. 1½ leghold traps are set on the raft with the chains stapled to the

underside. When a muskrat is caught it will jump into the water and drown. Do not use any trap smaller than a 1½, as it will be too small and the muskrat will be able to get back on the raft. For bait, rub muskrat musk on the pole and around the set. To keep ducks from getting caught, nail two willows diagonally from corner to corner, as shown. Visit your traps often.

Another good set is the submerged log set. In the spring muskrats travel up and down rivers and creeks, often using partially submerged logs that are in contact with the shore. They go up and down these logs and leave their scent and droppings there. These are good places to set traps. Set one on the log just below the water level and staple the chain to the underside of the log. For bait, rub muskrat musk on the log at the dropping pile.

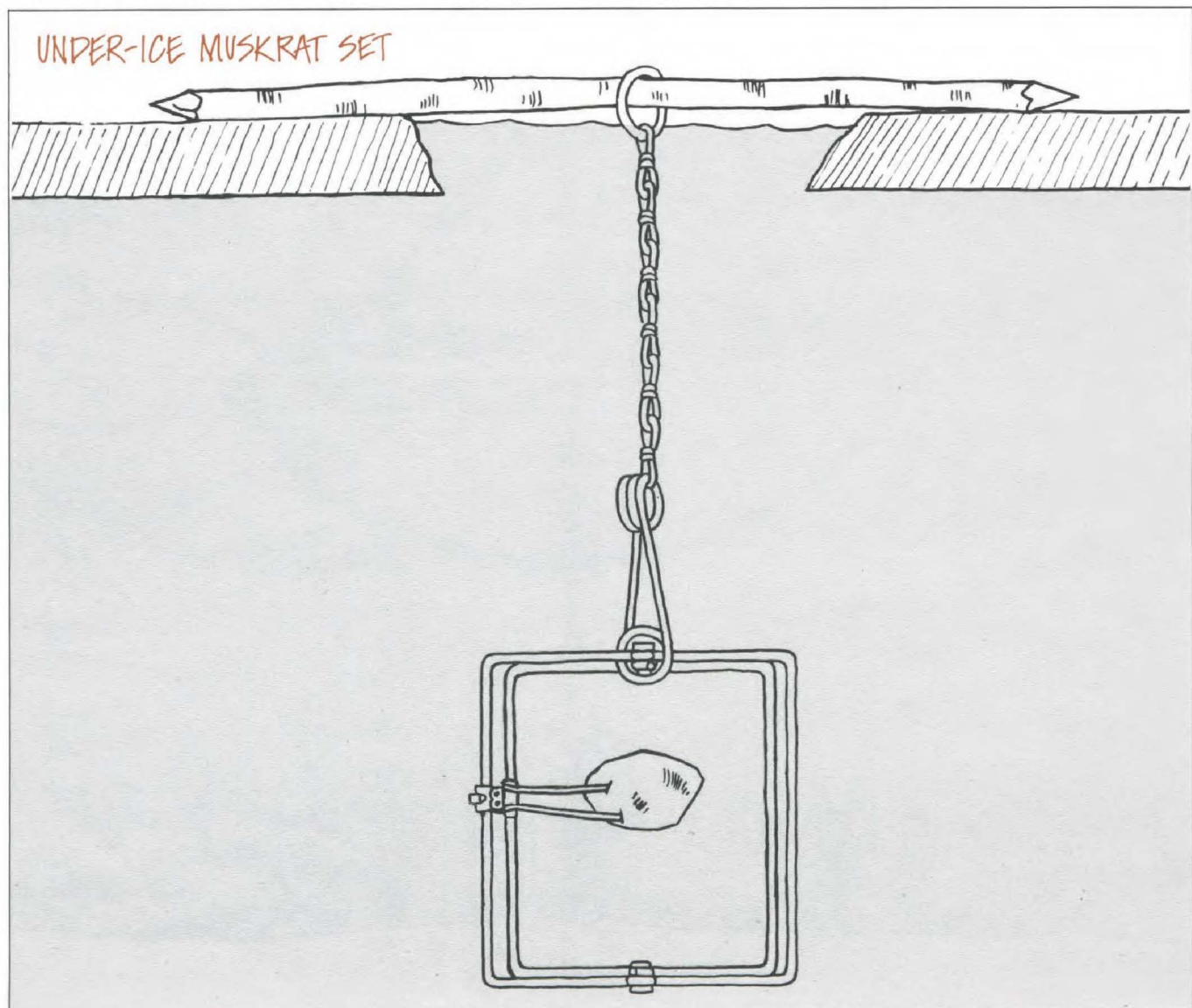

MUSKRAT FLOAT

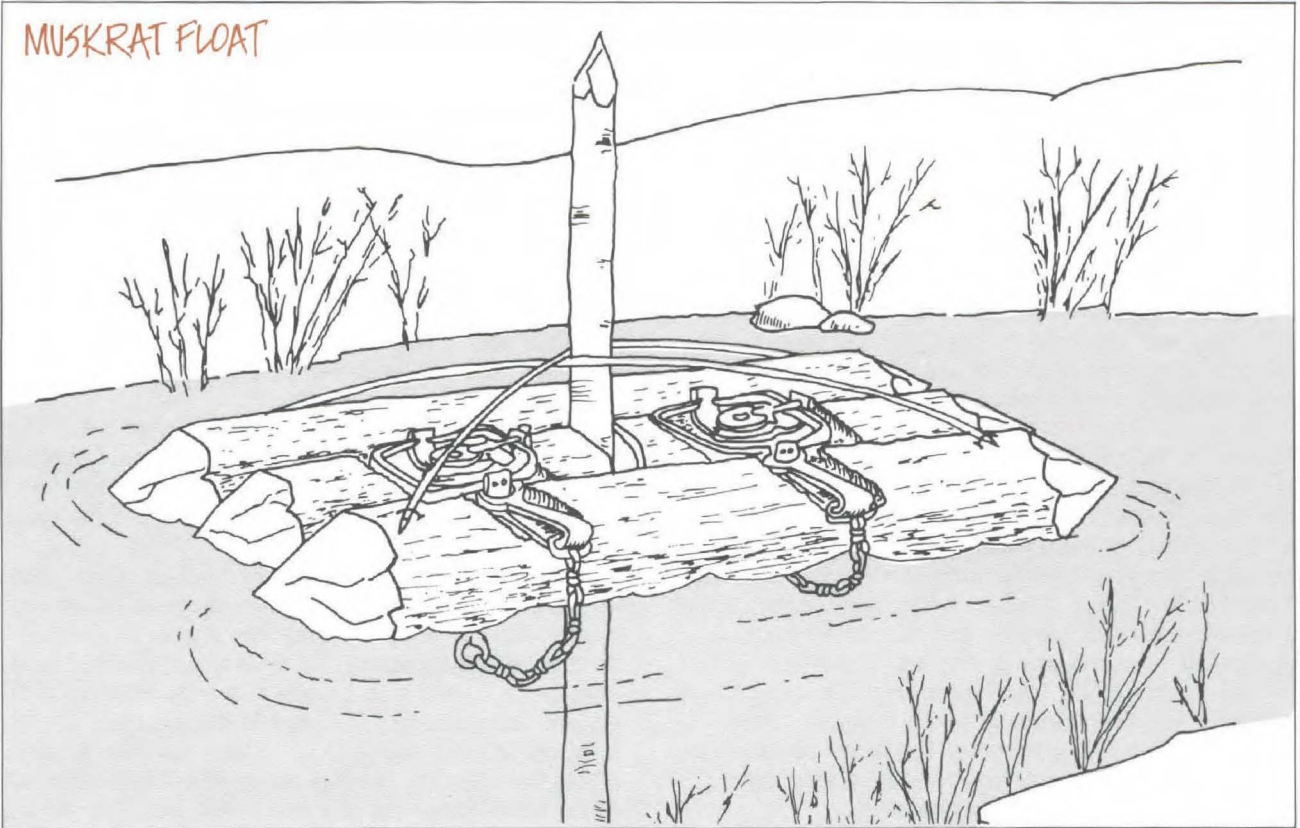

MUSKRAT LOG

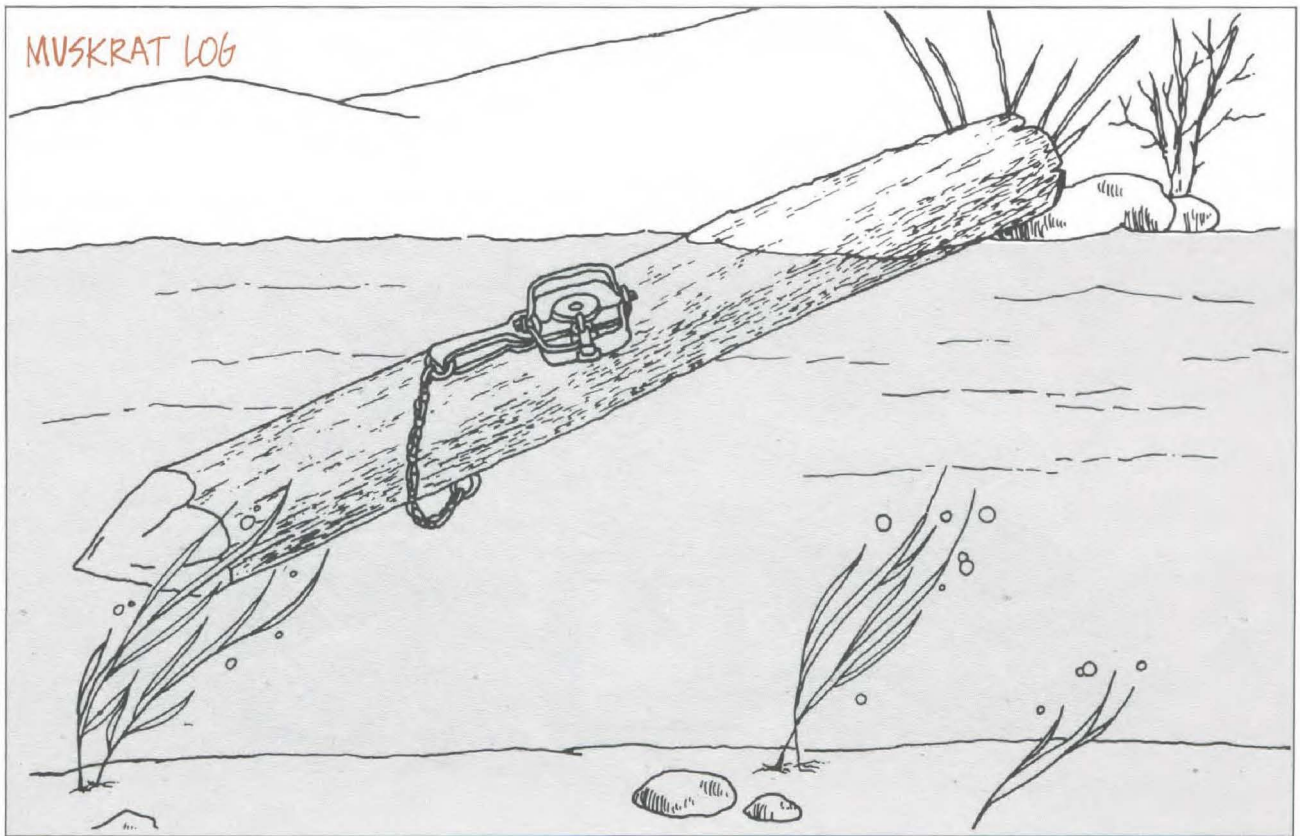



## Mink

Mink are found in most of the wooded areas of the NWT, including the Mackenzie Delta. They prefer to live near water, along small streams, rivers, lakes, muskrat sloughs and beaver ponds. During the winter months they prefer to live near open water (where the current prevents ice formation). Mink seldom travel far from their areas except during heavy snowstorms or during the breeding season. They are most active at night. For food they prey upon mice, squirrels, muskrats, hares, small birds and ducks. They also rob nests of eggs, and are good swimmers, able to capture small fish and crustaceans. Their dens are located in old beaver lodges, muskrat dens and holes in river banks.

Because of the mink's habit of staying close to open water and its preference for following the shores and banks of lakes, creeks and rivers, trappers will concentrate their efforts in these locations. Ideal places to set traps are in abandoned beaver lodges, old muskrat holes and dens on the shores of lakes, beside open water, above and below open rapids, at new and old beaver dams, in rock crevices, or along grassy clay and peat moss banks on the shores of creeks, lakes and rivers. The experienced trapper will set several traps in prime locations. Some spots can be used year after year. The writer recalls using one such place for 32 years and catching several mink there each year as well as other furbearers.

A sure place to catch a mink is where they have been going in and out of holes in the banks of rivers and lakes,

and old beaver lodges and rat dens. Such holes may have to be enlarged with an axe or chisel. Cut a piece of fish or other bait and push it into the hole so it will freeze to the ground and the animal will have to work to get it. If using a Conibear (No. 120), set it at the entrance. Spread the trigger and keep it in the centre of the trap so the mink will set it off with the hump of his back. This will ensure that the animal is caught securely. If using a leghold trap set it inside the hole approximately 22 cm from the bait, cover with dead leaves or grass and attach the chain to a line as shown in the illustration, so that the mink will drown when caught.

The traps should be set on a bit of hay or dried vegetation from near the site. Only dry sticks should be used on either side of the trap. Set your trap so it is sheltered from drifting snow, or cover it to protect it from falling snow or rain.

When using underwater sets for mink in winter, always set your traps under the ice either above or below a beaver dam, or under hanging ice. A pole is inserted through the coiled springs of a Conibear No. 120 or 220. The trap is baited with a small fish head attached to the trigger, and must be positioned in the direction of the current, not at right angles to it, as then the current may spring the trap. Set the trap about 30 cm below the bottom of the ice. Change the bait every time you visit the trap.

### BEAVER LODGE SET FOR MINK

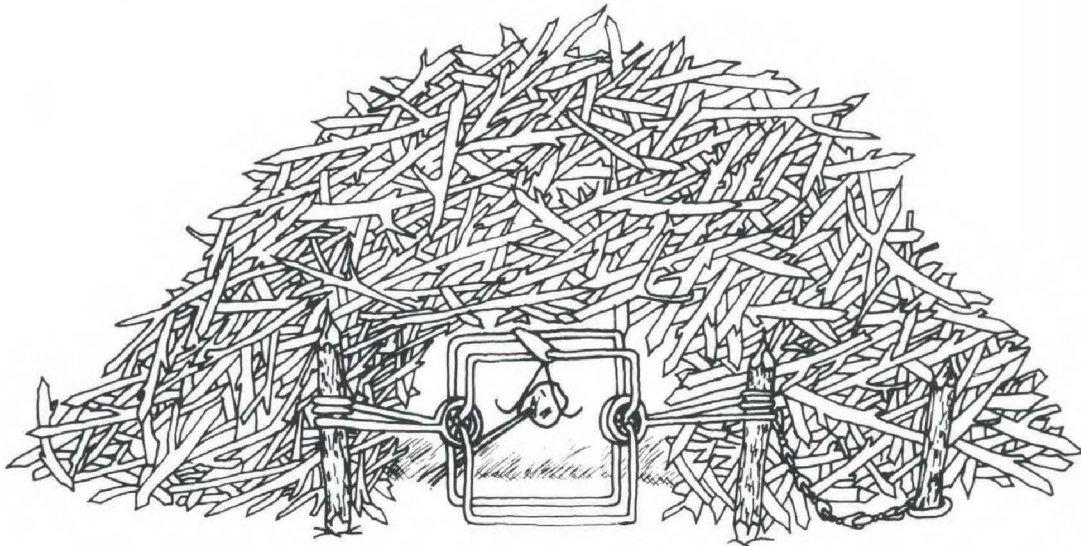



MINK LAKESHORE SET

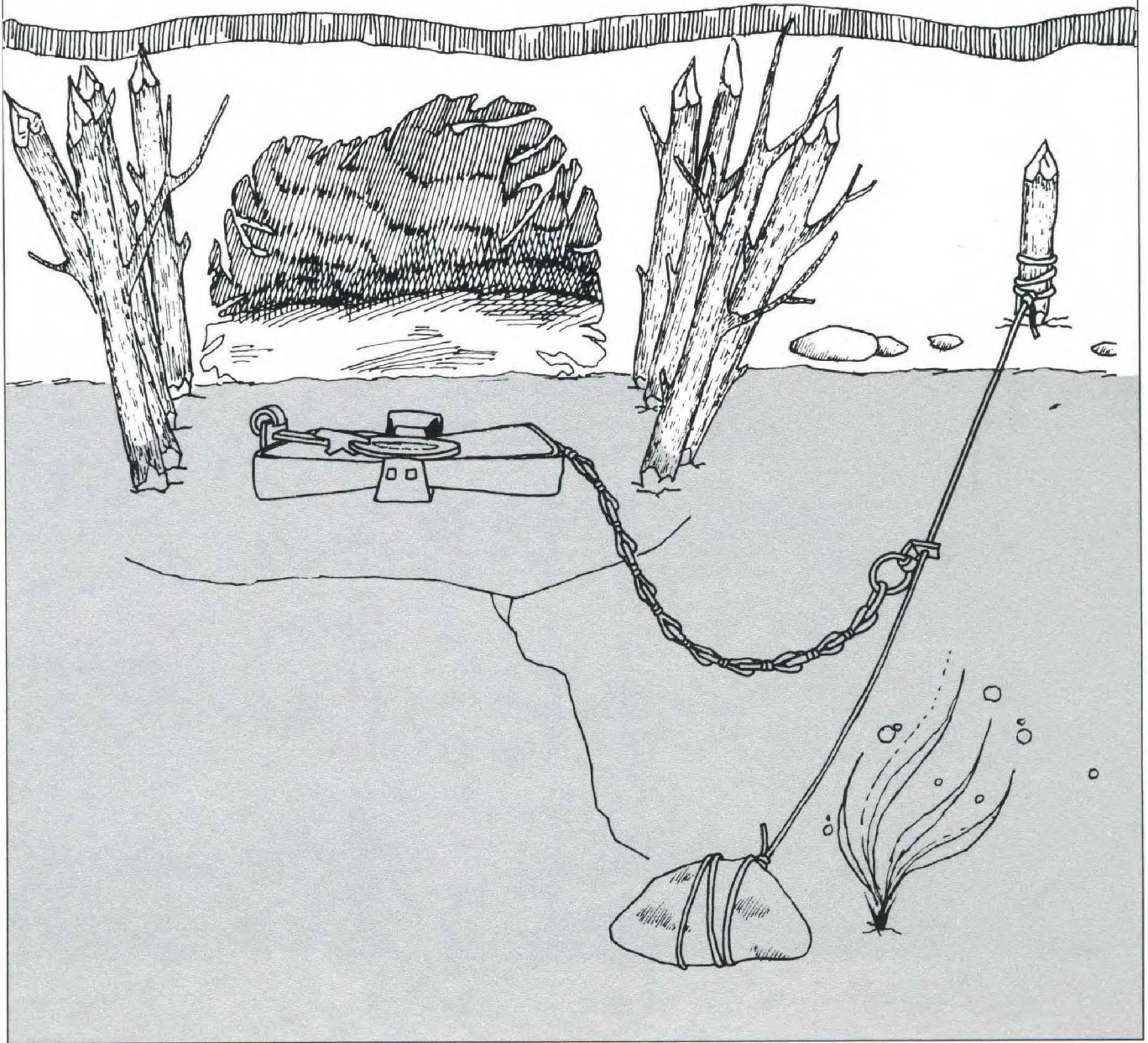



## Otter

Although otters are considered water animals, there are times when they will travel lengthy distances on land, especially during a snowstorm or blizzard to look for open water. Nevertheless, the place to trap otter is in the water and there are several successful sets for them.

The most successful set I have used is a Conibear No. 330 trap set on a pole with a jackfish head wired to the trigger. The pole is inserted through both coiled springs and set in an area of open water or thin ice, such as the top or bottom of rapids, or at the head of swiftly flowing streams. Always set your trap in the direction of the current, never at right angles to it, as the current will spring the trap. Set the trap in 1.5 m of water, with the trap at least 60 cm below the ice, and set several traps in

these good places. Otters are known to travel in whole families, and I have seen as many as seven in one bunch. Mink will also get caught in this set.

Another good set is the otter block set, which is similar to the beaver block set. It is baited with a whole fresh fish set 30 cm above a couple of No. 3 jump traps. Change the fish every third day, as otter prefer fresh fish to drowned fish.

Otter will sometimes get caught in mink or beaver sets. Sometimes they will enter old beaver lodges that have holes in them. This is an ideal spot to set traps. However, whenever setting traps for otter on land there is always the danger that a captured animal will be eaten by a wolf or wolverine.

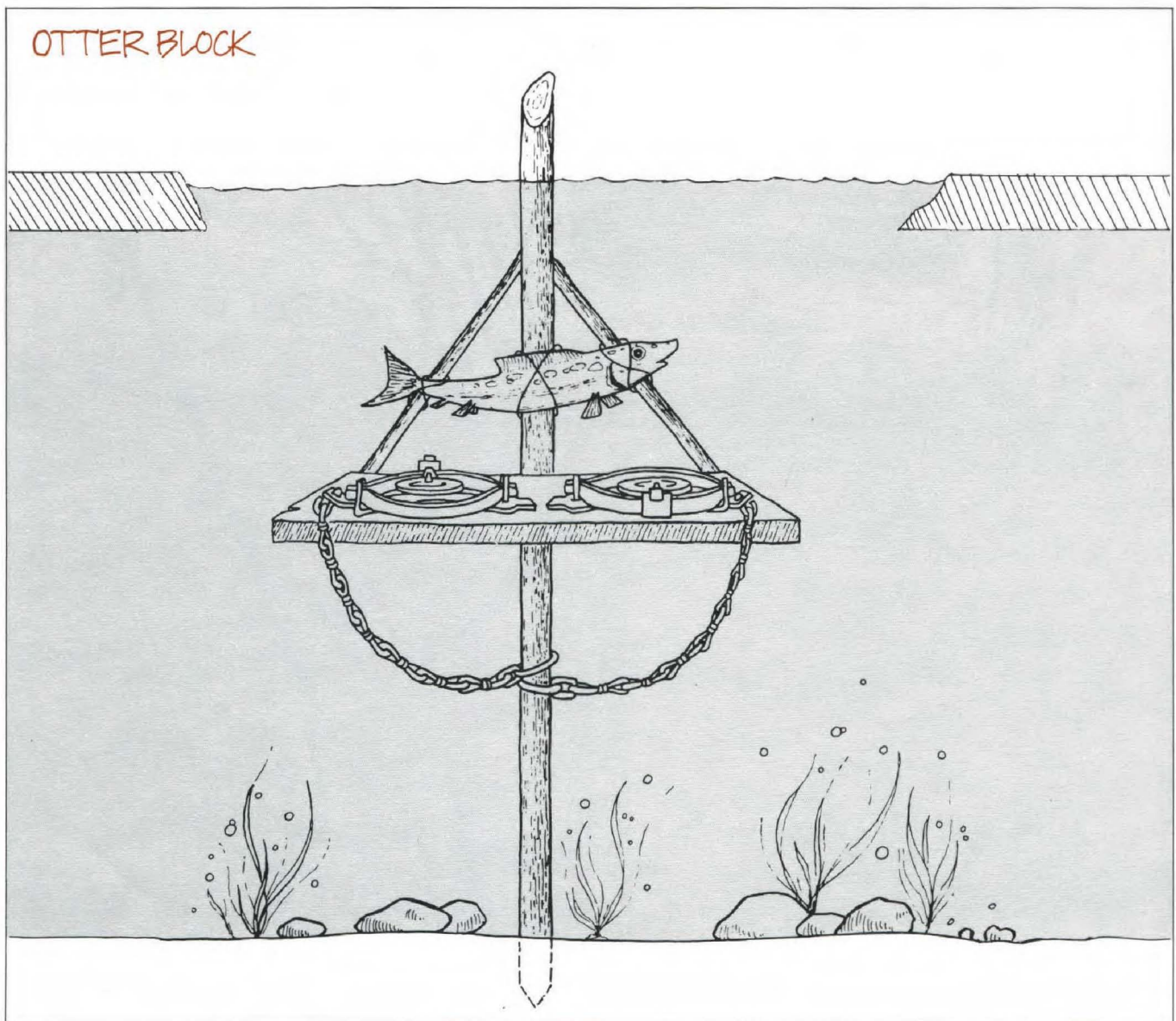

UNDER-ICE OTTER SET

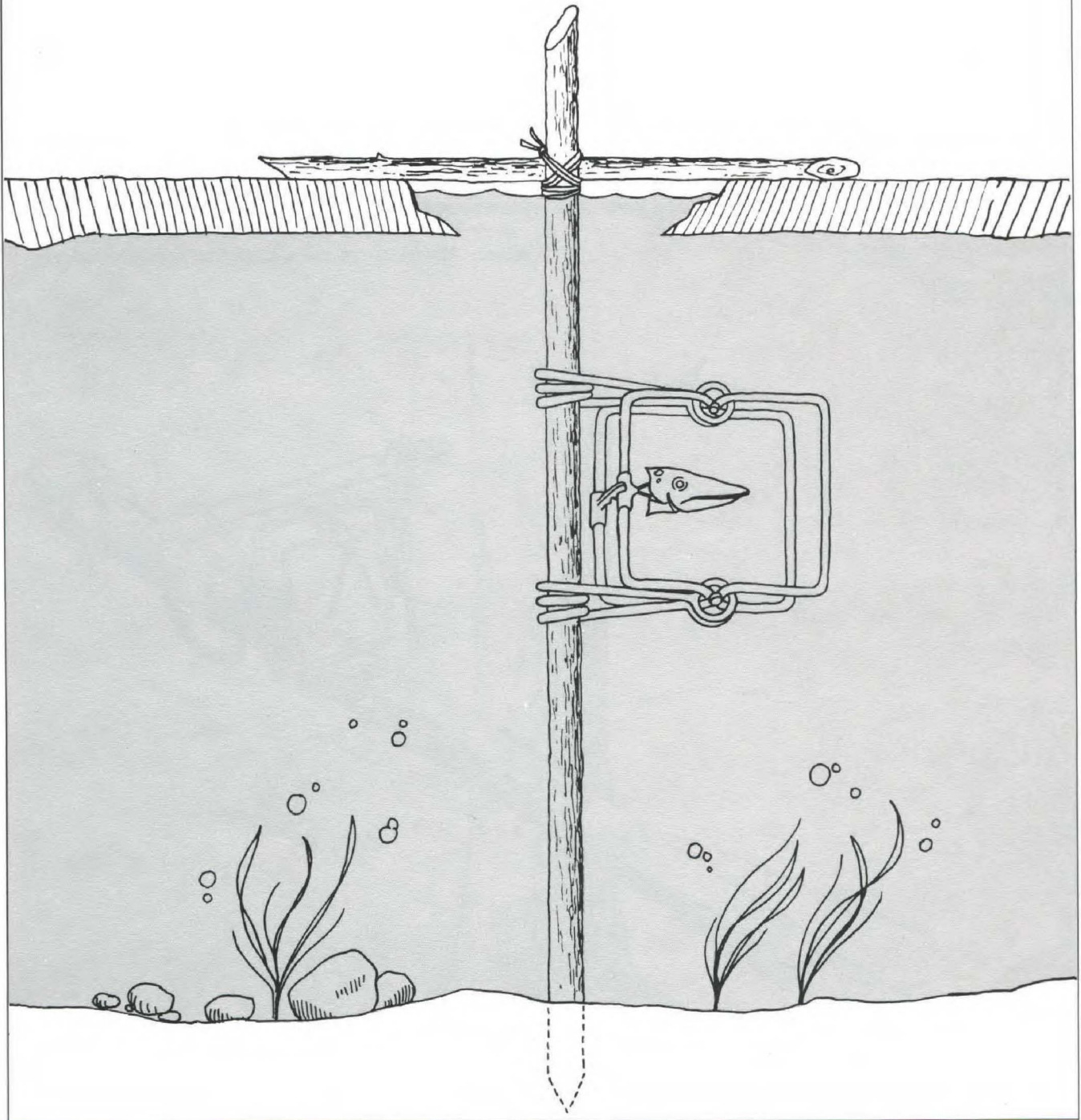



## Marten

Because of their curious nature, marten are one of the easiest animals to catch. Also the fact that they seldom travel on lakes makes it easier to find them. Marten occur in timbered country on jackpine ridges, in deep spruce valleys, and at the edge of timbered muskegs and swamps. Since their diet consists of voles, squirrels, hares, birds, berries and ants, the place to find them is in rotted wood piles and old dens of their prey. Their own dens are found in peat moss banks or at the edges of swamps.

The oldest method of trapping marten is by building a pen or cubby, but another set used widely by experienced trappers is the leaning pole set. The latter can be made by nailing a pole to a tree, as shown in the illustration, or by cutting a pole-size tree about 1.8 m from the ground and pulling down the top part to form a runway. Some people wire the bait to the underside of the pole to keep birds from eating it. The trap to use is a 120 Conibear.

### MARTEN POLE

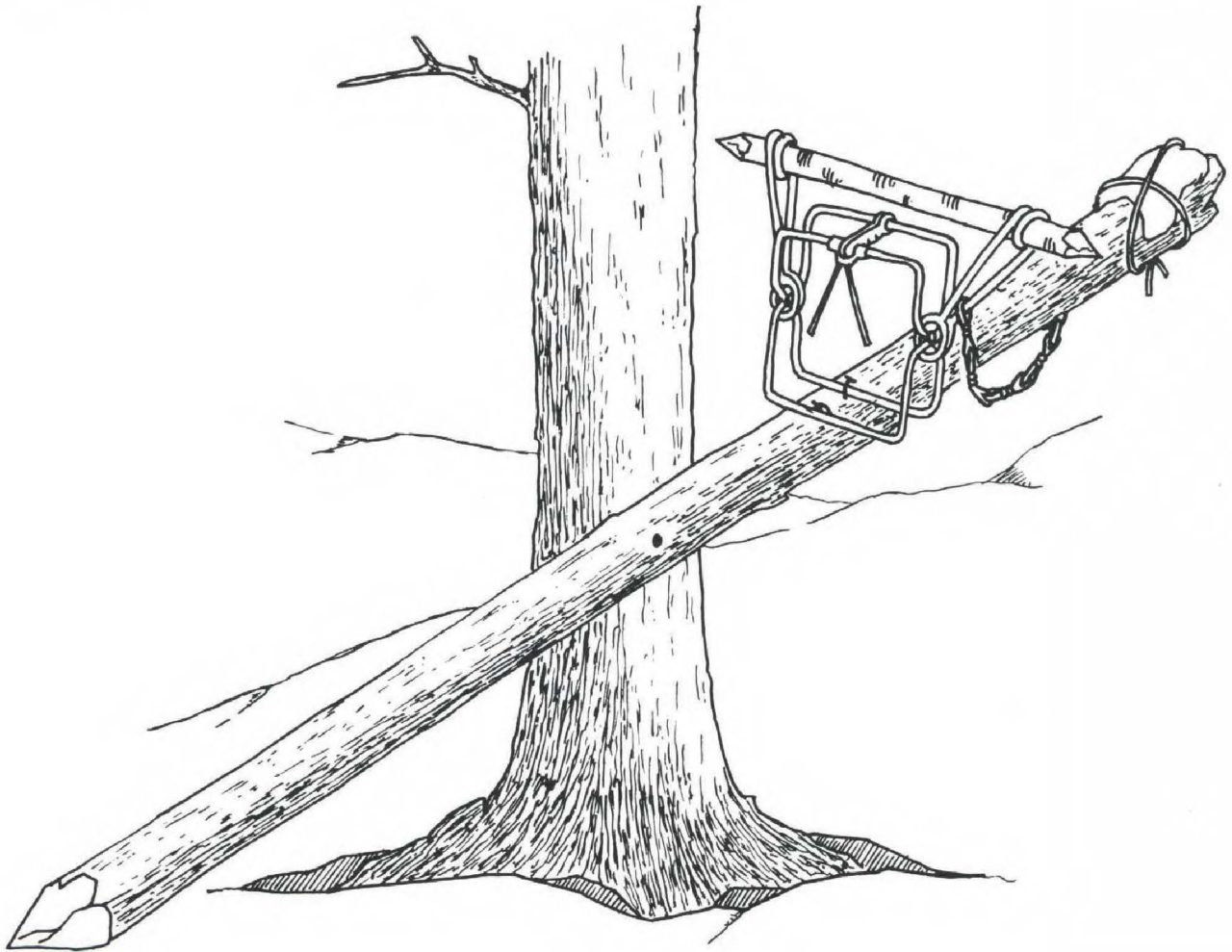

## Lynx

Lynx are curious animals and normally quite easily taken. To catch them, one must know where they pass in winter as well as in summer. They have regular routes, and will cross and follow your trail every year, usually in the same place. There, or anywhere else you have formerly caught lynx, are good locations to trap. If you are not familiar with the country you are in, try these places:

- a portage between two large lakes
- a beaver dam
- the head of a ravine
- where your own trail passes through a thick spruce valley

The usual set for lynx is a pen set. Great care must be taken to build it if you want to be successful. Lynx pens must be made out of dry sticks. If green wood is used, snowshoe hares will be attracted and get caught, spoiling your chances when a lynx comes by.

A proper-sized pen should be about 60 cm wide at the centre. Always try to use a large tree with overhanging

branches for snow cover, or a large overturned stump or willow thicket for the back of your pen. It should be constructed in such a way that the animal cannot reach the bait from the sides or from the back and must enter from the front of the pen to reach the bait. The sticks may be vertical like a wall or leaning inwards like a teepee. Some trappers however lean the sticks outward to keep the animal from having a free smell of the bait. In a well-constructed pen, the animal will get caught before it can smell or chew the bait.

The bait stick should be set at the back of the trap with the bait set at the lynx's eye level. If you're using a Conibear, attach the chain to the centre of a drag pole, which should be at least 1.8 m long. If you're using a snare, attach the end securely to a tree. Do not spit tobacco juice or throw cigarette butts near the pen. Keep dogs away from it and try to keep the areas as natural as possible.

## LYNX PEN

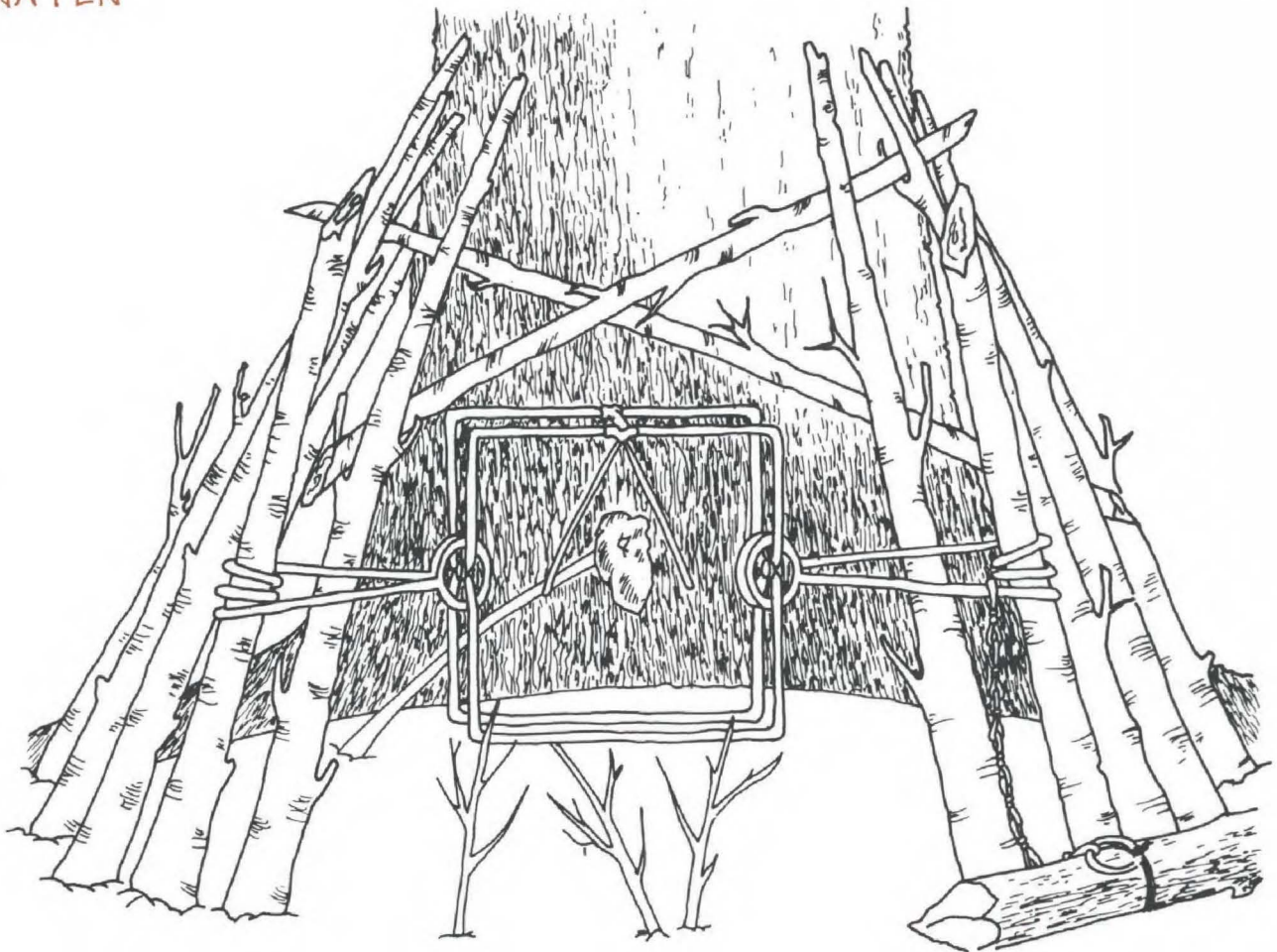



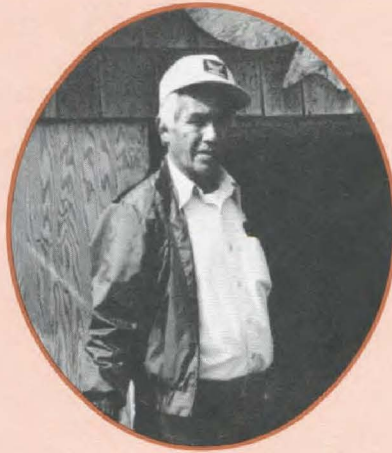

## Red Noyes

Red Noyes has worked on a variety of jobs throughout his life. When he was younger he freighted goods from Ft. Fitzgerald to Ft. Smith for three years. He worked as a patrolman in Wood Buffalo National Park during 1950-53, after which he worked for the Territorial Game Branch on predator control for six or seven years. For 17 years he spent each summer working at Frontier Lodge, a fishing lodge at Snowdrift on Great Slave Lake.

He started trapping in 1937 when he was 18. Louis Brown was his first partner; they trapped near Ft. Smith. Later he trapped in the Gray Lake area, outfitting himself from Snowdrift, to which he travelled by dogteam. He also trapped with Gus Dow on the barrens, at Beaver Hill Lake across from the Thelon.

Red remembers being on the barrens when the caribou were thick as flies around his camp. But another time, when he and Alex Desjarlais were trapping out past the Thelon after Christmas, there were

no caribou at all and not enough food for the dogs. The ice was too thick for fishing, and the only animals they found were hare and ptarmigan. Red had to kill his dogs at Tent Lake and walk back to Ft. Reliance, which was 130 km away. Without snowshoes he never would have made it.

Walking is something that all hunters and trappers know about. In the old days he'd start out for his trapline early in August. If there was no way to get there by water, that meant walking and using pack dogs. Something else most people know about is wolverines. Once a wolverine took all the caribou he had cached for the winter. Red says he had to learn how to hunt moose in a hurry that year.

Red now lives in Ft. Smith, having recently taken over his brother's trapline.

*Bernie Bergman  
Ft. Smith 1983*

# Notes on Humane Trapping

by Sally Stewart



Many hunters and trappers in the Northwest Territories are completely bewildered by the reports they receive of people agitating against trapping and the use of the leghold trap. They cannot understand why people in distant parts of Canada and the world wish to interfere in their way of life. "We've done nothing to them," they say. "We do not meddle in their lives or tell them what to do. Why can they not leave us in peace?" Those native people with a broader perspective see the movement as the latest example of alien manipulation of their culture. The initial confusion has often been replaced by anger and a "to hell with them" attitude.

The problem, however, is not one which will go away, and refusing to face it will only make matters worse. Opposition to trapping and the leghold trap is strongest in the same places where fur is ultimately marketed — in urban Canada, the United States, and Europe. It is unrealistic to expect to remain insulated from some aspects of the fur trade, yet to continue benefiting from other aspects of it. Remaining secluded today is even less possible because electronic media have shrunk the world and truly made it a global village.

The position of the government of the Northwest Territories is clear: it emphatically supports the concept of humane trapping and abhors the causing of unnecessary suffering in animals. It is working to educate trappers in this regard and to find alternatives to the leghold trap. However, because of the close association of trapping with native culture, and because of the extremely limited economic opportunities available to natives in the Northwest Territories, the government will continue to support trapping and the fur industry, as well as the use of the leghold trap until a suitable replacement can be found. By doing so the government is clearly placing the needs of people first, and animals second.

In the meantime, it is important that northerners have a clear understanding of the issues involved, as well as an insight into the current work to make humane trapping a reality.

The Editor



## Humane Societies

Humane societies exist to protect animals and prevent cruelty to them.

According to Section 402 of the Criminal Code of Canada, “**Everyone commits an offence who wilfully causes or, being the owner, wilfully permits to be caused, unnecessary pain, suffering or injury to an animal or bird.**”

Humane societies have been major contributors in getting animal welfare legislation through Parliament — legislation which protects animals whether in slaughter houses, show business, private homes, laboratories or farms.

All humane societies are opposed to cruel trapping methods. The opposition falls into two camps. There are those who have directed energy and financial resources into an attempt to have trapping stopped altogether, and those who, although they condemn trapping, have channelled all their resources into ways to eliminate cruel trapping methods.

The membership and support for these organizations is vast and covers a whole cross-section of society. Their use of ships and aircraft and their ability to fund motion pictures gives an idea of the extent of their financial support. All funds come from donations by the general public or businesses.

Whether one agrees or disagrees with their attitudes towards trapping, it should be recognized that their motives are of the highest. They believe they are doing something that is morally right, in protecting the rights of those who cannot speak for themselves, our animals.

## The Anti-Trapping Lobby

A commercial on European TV shows a beautiful woman wearing a white fur hat. She smiles into the camera and as her lips part she shows vampire fangs that drip with blood.

This is the kind of propaganda that has whipped up so much support for the anti-trapping movement.

In movies made by the Association for the Protection of Furbearing Animals (APFA), it is stated that the slaughter of animals for fur is pathetic, cruel and unnecessary.

Anti-trapping groups, such as Animal Welfare Institute, Beauty Without Cruelty, Fund for Animals, and many more, have made TV commercials and films, published books, pamphlets, newspaper advertisements and articles to generate public support for their ideology.

In “Canada’s Shame,” a film made by APFA, animals are shown horribly mutilated, writhing in traps and suffering long painful deaths. The aim of this film, explains commentator Bruno Gerussi, is to shock the viewers so profoundly they will actively join the protest to ban cruel trapping practices. People are urged to write to their Members of Parliament and to donate money.

In *Facts About Fur*, a book by the Animal Welfare Institute, it is said that trapping has caused the near extinction of many species. It condemns traps, trappers and the fur industry.

Photographs in the book show three-legged pets freed from leghold traps. Other photographs show a swan, a fawn and a golden eagle helplessly caught in these traps. It is said that for every one target species there are three unwanted animals caught.

### *Some Pro-Animal Organizations in North America*

*Animal Defense League of Canada*  
*Animal Liberation Front*  
*Animal Protection Institute*  
*Association for the Protection of Furbearing Animals*  
*Canadian Animal Rights Network*  
*Canadian Association for Humane Trapping*  
*Canadian Federation of Humane Societies*  
*Canadian Wolf Defenders*  
*Fund for Animals*  
*Greenpeace*  
*I-KARE Wildlife Coalition*  
*International Ecology Society*  
*International Fund for Animal Welfare*  
*Mobilization for Animals*  
*Sea Shepherd Conservation Society*  
*Society for the Prevention of Cruelty to Animals*  
*Whale Center*  
*Whale Protection Fund*  
*World Wildlife Fund*

### *Some Pro-Animal Organizations in the United Kingdom*

*Animal Activists*  
*Animal Liberation Front*  
*Animal Protectors Defence Group*  
*Animal Rights Association*  
*Animal Vigilantes*  
*Beauty without Cruelty*  
*Chickens’ Lib*  
*Compassion for Animals*  
*Council for the Prevention of Cruelty by Angling*  
*Greenpeace*  
*Hunt Saboteurs Association*  
*International Fund for Animal Welfare*  
*Marine Action Centre*  
*Royal Society for the Prevention of Cruelty to Animals*  
*Save Our Stags*  
*Society for the Abolition of Blood Sports*  
*Vegetarian and Animal Liberation Society*  
*Whale People*



The power of these groups was clearly demonstrated when they were able to stop the import of sealskins into the European Common Market. This protest was spearheaded by Greenpeace.

The International Fund for Animal Welfare, an international group, was responsible for the banning of Canadian fish products by two big supermarket chains in the United Kingdom as a protest against the seal hunt. They are working towards a European and American ban to the same end.

There are other anti-trapping groups who are aggressively militant. The Animal Liberation Front (ALF) and the Animal Rights Militia are illegal in the United Kingdom due to some of their activities.

### Humaneness is a Relative Value

Protest has been loudest in industrialized western nations; that is, in parts of Europe, in the United States and more lately in Canada. Only in these countries do the majority of people have sufficient of life's necessities and many luxuries. The state provides a safety net for those in need. People can afford to care about an issue like animal welfare. In developing countries where 40,000 children die each day, and life means poverty and disease, cruelty to animals is not an issue.

In Britain the wolf, bear and beaver were exterminated long ago. The few remaining deer are completely protected. Trapping is unknown, few people farm, and only the aristocracy and landowners are rich enough to hunt and fish for sport. The majority of the British general public view hunting as cruel and bloodthirsty: the wealthy do not need to kill to eat, and to do it for fun is abhorrent.

This attitude is directly related to the anti-trapping attitude. Often it is the wealthy who can afford to wear fur; therefore, it is a status symbol. The animal's death seems to be unjustified.

People living in an urban industrialized setting generally have a different attitude to nature than Northerners. Death as part of the chain of life is not so easily accepted. Meat comes from a supermarket and the one who eats has not had to kill. For many people the sight of a caribou in its natural environment inspires a feeling of awe rather than hunger.

The attitude to wild animals is different when life does not directly depend on them for food, clothing or as beasts of burden. Animals are not perceived as destroyers of crops by people who do not farm, nor as competitors for food by people who do not hunt. Wildlife to them is only for educational, aesthetic, scientific appreciation.

Many people have pets. They are kept as companions or substitute children, to care for and love. Feelings for pets become extended to all animals and generate widespread emotion at any action which may be perceived as cruelty towards them.

This was clearly demonstrated during the seal hunt protest. Although it is a fact that a blow on the head kills the seal pup instantly; that pups are generally weaned in 10 to 14 days and then abandoned by their mothers; that a seal consumes 1.5 tonnes of fish annually during the course of a 30-year life span, thereby threatening the east coast fishing industry; and that the harp seal population is increasing; yet the appeal of the pup with its large soulful eyes generated such emotional reaction, and horror at such perceived brutality, that widespread publicity and condemnation occurred as a result.

Many family entertainment films portray animals as having human attributes: they are brave, loving, and intelligent. It is a small step to the conclusion animals are citizens of the wild, entitled to the same treatment as people; that a humane person treats animals in the same way as he would treat another person.

Two thousand years ago, in the most civilized nation of the known world, Romans watched people and animals

• *England — More than fifteen hundred animal rights protesters stormed a fox breeding farm after a demonstration in Warwickshire last October.*

*During a three-hour siege, demonstrators damaged cars, refrigeration units, fox slaughtering equipment and fences. Many of the windows of the farm house were also broken.*

*Police reinforcements from all parts of the country were called in and a total of 150 officers were engaged against the protesters. After marching from Coleshill, demonstrators broke through a police cordon and rushed the farm with cries of "murderers" and "destroy the farms". For nearly three hours, police were kept busy moving from building to building in a mostly vain attempt to prevent damage.*

• *Scotland — In February, Scottish ALF activists carried out a series of raids against businesses linked with animal exploitation in the Glasgow area. ALF slogans and threats were painted on seven fur shops, four butcher shops, two pet shops and a "sports" shop. The raiders also attacked the Canadian consulate in protest against the aerial killing of 400 wolves in western Canada.*

• *New Zealand — ALF activists "hit" a Wellington fur shop in a midnight raid with buckets of red paint to symbolize "the blood shed by millions of furbearing animals" the world over. The raiders left posters explaining the trapping issue and a warning that the action was only a first step in "an escalating campaign against all forms of animal abuse" and exploitation.*

*Excerpts from Animal Rights Network News*



fighting to the death in an arena. Today no such activity would be sanctioned by any nation. Modern values of life have come to include not only the sanctity of all human life but that of all life forms.

## **The Canadian Federation of Humane Societies**

Incorporated in 1957, the Canadian Federation of Humane Societies (CFHS) represents 36 societies located across Canada. It boasts a membership of 150 to 200 thousand people. In 1982 it passed a resolution which stated that trapping is cruel and the Federation is opposed to it in principle, but recognizes that trapping will continue in the future. Therefore, the Federation is actively and constructively working towards the development and acceptance of more humane trapping techniques.

The CFHS was the first to generate interest in and to begin research to find alternative trapping methods. Its work in this area from 1968 to 1974 was turned over to the Federal Provincial Committee for Humane Trapping and formed the starting-point for the latter's own research.

The CFHS continues to play a role in making the public aware of unacceptable trapping techniques. It has run a direct mail campaign to this effect, and has also considered the possibility of laying criminal charges against the federal government for allowing the use of the leghold trap when alternatives are available.

## **The Canadian Association for Humane Trapping**

A member society of the CFHS is the Canadian Association for Humane Trapping (CAHT). It is involved in many programs to promote humane trapping. In cooperation with the Ontario Ministry of Natural Resources, it produced an educational film, "Trapping 80's," to be used as part of a trapper education course to show humane trapping methods. The Association also distributes a bulletin, holds presentations, and runs information booths at outdoor shows. It has sponsored an international conference on humane trapping and initiated an award to give formal recognition to those who have made significant contributions to humane trapping. One program in the past was the exchanging of legholds for Conibears, at a cost to the CAHT of \$40,000-\$50,000. This organization has also contributed financially to research into humane trapping.

It was the work of groups like the CFHS and CAHT, and the public pressure they orchestrated, which caused the government to take serious steps to research and find humane alternatives to inhumane trapping methods.

## **The Federal Provincial Committee for Humane Trapping**

The FPCHT began as a committee of the 1973 Federal-Provincial Wildlife Conference and remained in existence until 1981. Its purpose was to "recommend to provinces, traps and trapping techniques which will, in so far as the state of science or the art will allow, provide the greatest 'humaneness' in holding or killing of furbearers." When the work of the committee terminated, it recommended the use of certain trapping devices and techniques which could allow 98% of all furbearers to be taken humanely. A lengthy report was produced.

## **The Fur Institute of Canada**

The Fur Institute of Canada (FIC) was incorporated in 1983 to carry on the work begun by the FPCHT. It is a non-profit organization funded by the provinces, territories, federal government, and the private sector. It is dedicated to the conservation of furbearers and the optimum development of the national fur resource. It coordinates the development and use of humane trap technology. New techniques are being researched and promoted with a long term commitment of substantial financial funds, manpower and physical resources.

The FIC provides information to the general public about the fur industry, both current and historical, and about furbearers. It is attempting to improve the skill and knowledge of all people involved in the industry, as well as promote the industry itself.

In 1984 J.W. Bourque, Deputy Minister of the NWT Department of Renewable Resources, joined the board of the FIC.

## **The Leghold Trap**

For some people trapping itself is seen as cruel and intolerable, and not to be sanctioned under any circumstances. The more radical of these, such as the Animal Liberation Front, have engaged in illegal, terrorist-style activities.

Other more reasonable people have focused their activities on eliminating what they see as cruel trapping techniques. The leghold trap is at the centre of this controversy.

The leghold trap works in the following way: an animal steps on the pan or trigger and the jaws snap closed on the leg. The purpose of the trap is to hold the animal until the trapper returns. The trapper then dispatches the animal. Many people have the impression that the jaws close with crushing force. This is not so. Nor are the jaws armed with teeth.



The horror stories associated with the leghold trap originate from its use in milder climates. If a trapper does not check his traps daily in areas where winter is less severe than in the North, animals can survive for days and may eventually chew off the trapped leg or break it in repeated efforts to free itself. In the Northwest Territories this is less likely to happen because of the severe cold which is usually the cause of death.

Another complaint about the leghold trap is the claim that it cannot be targeted only for the desired species. This results in the capture of unwanted animals such as birds or pets. However, in the Northwest Territories at least, the inadvertent capture of pets is not a problem due to the low population density. Skillful trappers are able to minimize, if not eliminate, the capture of unwanted species through the choice of location and trap set.

When used as a drowning set, the leghold trap is considered humane. Recent attempts to modify the leghold have included padding the jaws, offsetting the jaws so they do not meet when closed, and shortening the chain to reduce injuries inflicted by the animal lunging.

Nevertheless, the leghold trap is completely or partially banned in more than 50 countries and several American states. Many of these countries are tropical, where people do not trap for a living, such as Trinidad, India, and Mozambique; or European countries where people do not depend on trapping and it is virtually unknown.

In the province of British Columbia, the leghold trap is banned as a holding device in most land-based trapping, and only modified foot traps with offset or cushioned jaws are allowed for fox, wolf and coyote. Ontario has similar legislation, and other provinces are considering it.

## Killing Traps

Other traps have been developed as replacements for the leghold trap. These usually are of the quick-kill type. They are meant to be set so that a bar or some other striking apparatus hits the animal in the head, neck or back. These traps close with far greater power and impact than leghold traps, and are meant to kill quickly. Any trap which does this is considered humane.

Some, such as the Conibear trap (developed by former NWT trapper, Frank Conibear), have been around for years. The reasons they have not been more widely adopted by trappers are several. Humane traps are heavier and more bulky than leghold traps — an important consideration for the northern trapper, who must carry all his gear in a sled or komatik where space is limited. The traps are more difficult to set, and in some cases (for example, coloured fox) will simply not work. A common complaint about the Conibear is that its catch is frequently frozen to the trap, requiring the trapper to carry the trap and the animal back to camp to thaw it out, and to have a replacement on hand if he wants to keep the trap site active.

Killing traps will not work for all animals. The FPCHT recommended they not be used for fox, coyote or wolf because the energy levels required to make them work would be too dangerous. Despite the variety of killing traps produced in the last few years, the Conibear still remains the most widespread. NWT trappers may obtain Conibear traps (or any other humane trap on the market) at no cost to themselves by applying for a grant through their Renewable Resource Officer.

*"In the months since my daughter's death, I have learned a few things about wildlife management from animal damage control experts here in Los Angeles County.*

*"Thanks to concerned experts who have consulted with me since my three-year-old little girl, Kelly, was attacked and killed by a coyote on our front lawn August 26, 1981, I have learned one very important lesson; Kelly would still be alive today if a sensible management programme for coyotes had been in effect in our area. This programme would have included a well-regulated harvest utilizing the leghold trap: the only device proven reliable in capturing numerous species.*

*"I want to make it clear that I harbor no ill will toward coyotes. I realize that the animal that attacked and killed my daughter (and the coyotes that*

*attacked our other children) was only following its natural instincts.*

*"Additionally, I harbor no ill will toward well-meaning people who have strong concerns for the well-being of wildlife.*

*"However, I do regard, with great contempt, those who are so narrow-minded that they refuse to see the benefits — to people and wildlife — of judiciously applied programmes of wildlife management. I am unable to see the logic in their pointless crusade to outlaw the only feasible method of controlling burgeoning coyote populations, the leghold trap."*

*Catherine Keen*

*(from an address to the  
Legislative Assembly of California)*



## Snares

Snares have been widely used to capture animals. They are cheap, lightweight, and easy to use. They are set so that an animal's head enters the loop and its forward progress tightens the snare. They are effective for smaller animals such as squirrels and hares, and have also been used with varying success for larger animals such as foxes, coyotes, wolves, and lynx.

Recent developments include the use of snare locks, which prevent a tightened loop from loosening, and the use of a mechanism (called a power snare) to pull the loop tight quickly.

## The Trapper

In books and films by anti-trapping groups the trapper is portrayed as brutal and insensitive to animal suffering. In the film, "Cry of the Wild," the trapper is the interloper in nature's idyllic world. While the animals writhe in agony in the traps, he enjoys a pleasant cup of tea before his banked fire.

This and other unfair portrayals have been used to good effect in the media war against trapping. So powerful are the images that they override any opposition, however sane and reasoned. The fact is that such methods are often not only unscrupulous but also dishonest. The seal hunt controversy is a good example. Though the whitecoat hunt has been virtually discontinued, protestors still employ the same pathetic images to recruit donations, which are then used for other purposes.

In the Northwest Territories, where employment is limited in isolated communities, trapping offers an alternative to welfare. Native people often use the word trapping when they mean hunting, fishing and living on the land. It means being self-supporting and independent. It restores self-esteem and pride in the considerable skills necessary to live on the land.

*"To Moore and his businessman crew, the seal pups are a commodity to be exploited for the bleeding hearts dollars they can wring from the issue throughout North America and Europe. . . .*

*"These professional opportunists are as dependent upon the continuation of the seal hunt as the sealers themselves. When the seal hunt ends, so also will end the fat cheques which pay Greenpeace salaries, rent for their Vancouver office, jet-fare for their globe-trotting escapades, and, of course, the charter fee for the annual Greenpeace summer ocean cruise to "save" the whales. Greenpeace needs the hunt more than the Newfoundlanders do."*

*Paul Watson,*  
former Director, Greenpeace Foundation

It should also be realized that trapping in the North involves hardships that few other Canadians would endure. It means living in tents at temperatures of -40°C with no running water, or central heating, or flush toilets or handy supermarkets, or television, or washing machines, or power. It's not an easy life.

## Trapper Ethics

Trappers must be aware of changing attitudes in society, and be prepared to change as well. Just as the mad scramble after bowheads, the wasteful slaughter of bison, and the ruthless exploitation of passenger pigeons would no longer be tolerated today, cruel trapping methods are deplored by all and must be stopped.

The NWT Department of Renewable Resources recommends that northern trappers adopt the following code of ethics:

### General

- 1 Attain the highest degree of humaneness possible.
- 2 Avoid capturing unwanted animals.
- 3 Avoid taking animals when the fur is not prime.
- 4 Check traps at least every 3 days.
- 5 Use proper release and killing methods.
- 6 Use the correct skinning and fleshing procedures, and attain the highest degree of proficiency in handling fur.
- 7 Dispose of animal carcasses properly, in accordance with local customs or religious beliefs.
- 8 Report any sign of abnormal behaviour or disease in animals to the nearest Renewable Resource Officer or RCMP Officer.
- 9 Encourage and support trapper education and public awareness programs. Teach new trappers proper conservation and harvesting methods.
- 10 Support your local Hunters and Trappers Association.

### Specific

- 1 Only kill-type traps should be used for marten, fisher, weasel and wolverine; for squirrel (when not being snared); and for any aquatic species (mink, beaver, muskrat, otter) when drowning sets are not used.
- 2 Leghold traps, when attached to a solid anchor and set on land, should have a short (20 cm) chain for a minimum of free play.
- 3 All drown-type shore sets should use locks and slide wires, or weighted traps, and be set so that the animal is carried into sufficiently deep water.
- 4 Snares set on land should be equipped with locks (except for squirrel and hare).



- 5 Only leg snares and cage traps, or shooting, should be used for bears.
- 6 All traps and snares should be anchored to hold the largest potential catch.

## Trapper Education

Trapper education encompasses a variety of subjects. Certainly, communicating the code of ethics is one of the most important tasks. Trappers must be knowledgeable, responsible, and beyond reproach in the way they set their traps and handle their fur. Leghold traps can be used as killing traps under some circumstances, while snares and killing traps can be inhumane if not set properly. It is the trapper who makes the difference.

Handling fur is equally important. It makes no sense to kill an animal for its fur, then remove the pelt the wrong way or stretch it improperly.

Trappers must also be aware that they are not working in a vacuum; they must be receptive to change and continue to upgrade their skills and techniques. To encourage this attitude, the subject of trapper training is being closely examined by fur managers and trapper associations across the country. The territories and the provinces of western Canada are working toward a standardized training course and a central facility for training instructors. In some places, trapper training is already mandatory.

The NWT has sponsored the attendance of trappers at an advanced course given in Lac La Biche, Alberta. It has field tested new trap designs, produced educational videotapes, provided financial support to the FIC, and endeavoured to acquaint northern trappers with the current situation in the fur industry and the need for change.

For further information contact:  
Supervisor, Fur Management  
Department of Renewable Resources  
Government of the Northwest Territories  
P.O. Box 1320  
Yellowknife, NWT  
X1A 2L9  
(403) 873-7134

## The Fur Industry

Trapping exists because of the fur industry, which exists because people want to wear fur. The economic aspects of this industry in Canada are not minor:

Approximately 80,000 to 100,000 people work as trappers on a full or part-time basis. Of these, it is estimated that about one half are Indians, Inuit or Metis. In the past five years, total payments to trappers for raw fur pelts have ranged from \$45 to \$85 million. These figures take on an added importance when one considers the lack of economic alternatives available to these thousands

of trappers, many of whom are already economically disadvantaged, and who live in small northern communities. In 1980, the fur processing and manufacturing industry, which is centred in Montreal, employed approximately 2,500 people in 310 establishments. Salaries and wages totalled approximately \$38 million.

The fur industry in Canada, including trapping, ranching, processing, manufacturing and retail sales, adds approximately \$600 million annually to the Gross National Product. Over the past 20 years, exports of furs in all stages — raw, dressed and garments — have increased dramatically. From a total value of \$30.5 million in 1962 exports reached a high of \$313.4 million in 1980, falling back to \$263.2 million in 1982. In the last five years, the total value of fur exports has been \$1.3 billion, averaging \$261.8 million per year. The main countries to which Canadian furs and fur products are exported are the United States, Switzerland, the Federal Republic of Germany, the United Kingdom, Japan and Italy. The Canadian fur manufacturing industry has grown significantly in this period and now enjoys a world-wide reputation for quality production. Statistics Canada reports that the value of manufactured goods produced in this sector in 1980 totalled \$325 million, with a value added of \$80 million. Canada ranks as the third most important producer of furs, behind the United States and the USSR, but it is ranked at the top for the quality of the furs it produces.

### *Trapping in Canada*

Disruption of this industry would have widespread repercussions throughout Canadian society.

## Conservation

In the past people worried little about the effect of their activities on wildlife. Bison, the passenger pigeon, the bowhead whale, and other species were exterminated or brought close to the brink of extinction.

Attitudes have changed vastly in this century and people are now concerned about the conservation of all our resources, renewable and non-renewable. In 1970 a voluntary ban by the International Fur Trade Federation on the trade in skins of five vanishing species showed that the fur industry shares this concern.

In 1975 the Fur Conservation Institute of America stated, "If any one group is concerned about the conservation of animal species, it is the fur industry. A plentiful supply of furbearing animals is essential to the fur industry's continued life and growth if it is to remain a healthy industry."



Trapping, like hunting, is a widely accepted means of managing wildlife. Every year a certain number of wild animals die from natural causes. As long as the mortality rate does not exceed the birth rate, populations will remain stable. The number of animals produced in excess of this level is often termed the "harvestable surplus". Often it is preferable for man to interfere in the natural cycle because, if left to seek its own level, the result can be a dramatic rise in the number of animals, followed by over-utilization of food resources, starvation, and spread of disease, and a decimated population whose numbers end up below the original level. The humaneness of allowing this to occur is debatable.

*"Those familiar with wildlife and its prolific reproduction capacity recognize the fallacies inherent in the preservationist and animal rights philosophies. Those not familiar with the facts may well fall victim to the emotional rhetoric of these zealots and self-appointed experts.*

*"Animal rights are a case in point. Do all animals have rights, or are these reserved for the cute, cuddly kind with doe-soft eyes? Will the rats that infest our sewers and refuse swamps be afforded equal status with other species? If so, our world will soon be full of wildlife. Rats can produce up to 12 litters of 8-10 young each year, and females breed at 3 months of age. It should not be difficult to calculate the increase if control measures are terminated. If rats are not to be afforded rights, who is to decide which species are included and which are rejected?"*

*"The preservationist and animal rights philosophies are based wholly on emotional theories, without foundation in reality, law or biology."*

Ken Brynaert, Executive Vice President,  
Canadian Wildlife Federation

## If You Eat Chicken You Can Wear a Fur Coat

The wearing of fur has become a moral issue. But in essence the utilization of furbearers for their pelts is no different from the rearing of domestic cattle for food and leather. To condemn one is to condemn the other.

This distinction has not been overlooked by some pro-animal groups. They espouse not just vegetarianism, but the complete disengagement of human interference in animal affairs. This means no hunting or trapping or fishing. No zoos or the use of animals for entertainment (in circuses, films or races). No medical or scientific experiments using animals. No raising of animals for food or clothing. No pets.

Also rejected is one of the traditional tenets of wildlife management — that of "sustainable harvest". If man must meddle with wildlife in its own interest (for example, to prevent drastic population increases), then he must bend himself to discovering techniques which do not involve killing, such as animal birth control.

One aspect of this question which must be addressed by pro-animal groups is the subject of habitat. The greatest threat to wildlife today is the loss of habitat as a result of human population expansion. This too must be controlled for the sake of animal rights.

The philosophical house of cards becomes very shaky at this point. It highlights the basic dilemma: when do human rights outweigh animal rights?

Everyone seems to have a different answer.

# Further Reading

- Asch, M. 1976. "Some Effects of the Late 19th Century Modernization of the Fur Trade on the Economy of the Slavey Indians." *Western Canadian Journal of Anthropology* 6(4).
- Basic Trapping, Fur Handling & Conservation*. Alberta Dept. of Energy and Natural Resources.
- Berger, T. 1977. *Northern Frontier, Northern Homeland: The Report of the Mackenzie Valley Pipeline Inquiry*. (Vol. I.) Supply and Services Canada.
- Bockstoce, J. 1977. *Steam Whaling in the Western Arctic*. Old Dartmouth Historical Society.
- Brynaert, K. 1984. "Animal Rights and the Facts of Nature." *International Wildlife* (Nov./Dec.).
- Campbell, M. 1983. *The North West Company*. Douglas and McIntyre.
- Canadian Trappers Manual*. Canadian Trappers Federation, North Bay Ontario.
- Cooke, A. and C. Holland. 1978. *The Exploration of Northern Canada 500 - 1920: A Chronology*. Arctic History Press.
- Crowe, K. 1974. *A History of the Original Peoples of Northern Canada*. Arctic Institute of North America.
- Ellis, E. 1967. *Northern Cookbook*. Dept. of Indian Affairs and Northern Development.
- Francis, D. 1984. *Arctic Chase: A History of Whaling in Canada's North*. Breakwater Books.
- Freeman, M. (ed.) 1976. *Inuit Land Use and Occupancy Project*. (Vol. I-III.) Dept. of Indian and Northern Affairs.
- Fumoleau, R. (1973.) *As Long as This Land Shall Last: A History of Treaty 8 and Treaty 11, 1870-1939*. McClelland and Stewart.
- Fur Harvest, Fur Management, Conservation Course* (Books I-III.) Ontario Ministry of Natural Resources/ Ontario Trapper Association.
- Hargrave, M. 1965. "Changing Settlement Patterns amongst Mackenzie Eskimos of the Canadian North Western Arctic." *Albertan Geographer* No. 2.
- Hobart, C. 1981. "Impacts of Industrial Employment on Hunting and Trapping among Canadian Inuit." *Proceedings: First International Symposium on Renewable Resources and the Economy of the North*, edited by M. Freeman. Association of Canadian Universities for Northern Studies/Canada Man and the Biosphere Program.
- Hunt, C. 1976. "The Development and Decline of Northern Conservation Reserves." *Contact* 8(4).
- Innis, H. 1970. *The Fur Trade in Canada*. (Revised Edition.) University of Toronto Press.
- Jotham, N. 1983. "Is Trapping Cruel?" *Nature Canada* (April/June).
- MacKinnon, C. 1980. "Portaging on the Slave River (Fort Smith)." *Musk-Ox* 27.
- Manitoba Trappers' Guide*. Manitoba Dept. of Mines, Natural Resources and Environment.
- Mitchell, J. 1982. "The Trapping Question. Soft Skins and Spring Steel." *Audubon* (July).
- Morris, M. 1973. "Great Bear Lake Indians: A Historical Demography and Human Ecology. Part II — European Influences." *Musk-Ox* 15.
- Nilsson, G. 1980. *Facts About Furs*. (3rd edition.) Animal Welfare Institute.
- Okpik, A. 1966. "Bewildered Hunters in the Twentieth Century." *North* 13(4).
- Perry, B. and W. Clark. 1971. "Fort Providence, NWT." *Musk-Ox* 8.
- Rich, E. 1967. *The Fur Trade and the Northwest to 1857*. McClelland and Stewart.
- Robinson, M. and J. Robinson. 1946. "Fur Production in the Northwest Territories." *Canadian Geographical Journal* (Jan.).
- Robinson, M. and J. Robinson. 1946. "Exploration and Settlement of Mackenzie District, NWT (Part I)." *Canadian Geographical Journal* (June).
- Robinson, M. and J. Robinson. 1946. "Exploration and Settlement of Mackenzie District, NWT (Part II)." *Canadian Geographical Journal* (July).
- Ross, W. 1975. *Whaling and Eskimos: Hudson Bay 1860-1915*. National Museums of Canada.
- Ross, W. 1979. "The Annual Catch of Greenland (Bowhead) Whales in Waters North of Canada 1719-1915: A Preliminary Compilation." *Arctic* 32(2).
- Simmons, H. and S. Miller. 1982. *Notes on the Vascular Plants of the Mackenzie Mountain Barrens and Surrounding Area*. NWT Dept. of Renewable Resources Information Report No. 3.
- Stager, J. 1962. "Fur Trading Posts in the Mackenzie Region up to 1850." Canadian Association of Geographers, British Columbia Division, *Occasional Papers in Geography* No. 3.
- Stewart, S. (ed.) (In prep.) *We Remember. An Oral History of the Mackenzie Valley by Dene Elders*. Slavey Research Project, Ft. Providence.
- Tetso, J. 1970. *Trapping Is My Life*. Peter Martin Associates.
- Tinling, R. 1982. *Northwest Territories Fur Production, 1957-58 to 1978-79*. NWT Dept. of Renewable Resources Information Report No. 1.
- Trapping in Canada*. 1985. Environment Canada.
- Treude, E. 1975. "Studies in Settlement Development and Evolution of the Economy in the Eastern Central Canadian Arctic." *Musk-Ox* 16.
- Usher, P. 1971. *Fur Trade Posts of the Northwest Territories, 1870-1970*. Dept. of Indian and Northern Affairs.
- Usher, P. 1971. *The Bankslanders: Economy and Ecology of a Frontier Trapping Community*. (Vol. I-III.) Dept. of Indian and Northern Affairs.
- Van Stone, J. 1963. "Changing Patterns of Indian Trapping in the Canadian Subarctic." *Arctic* 16(3).



- Walker, M. 1984. *Harvesting the Northern Wild: A Guide to Traditional and Contemporary Uses of Edible Forest Plants of the Northwest Territories*. Outcrop, Yellowknife.
- Wilder, E. 1976. *Secrets of Eskimo Skin Sewing*. Alaska Northwest Publishing Co.
- Williamson, R. 1971. *Canada's Changing North*. McClelland and Stewart.
- Wonders, W. (ed.) 1971. *Canada's Changing North*. McClelland and Stewart.
- Zaslow, M. 1971. *The Opening of the Canadian North, 1870 - 1914*. McClelland and Stewart.



